

## Tips for the operator

Extracts from ABB Turbocharging's  
Turbo Magazine 1990 – 2007

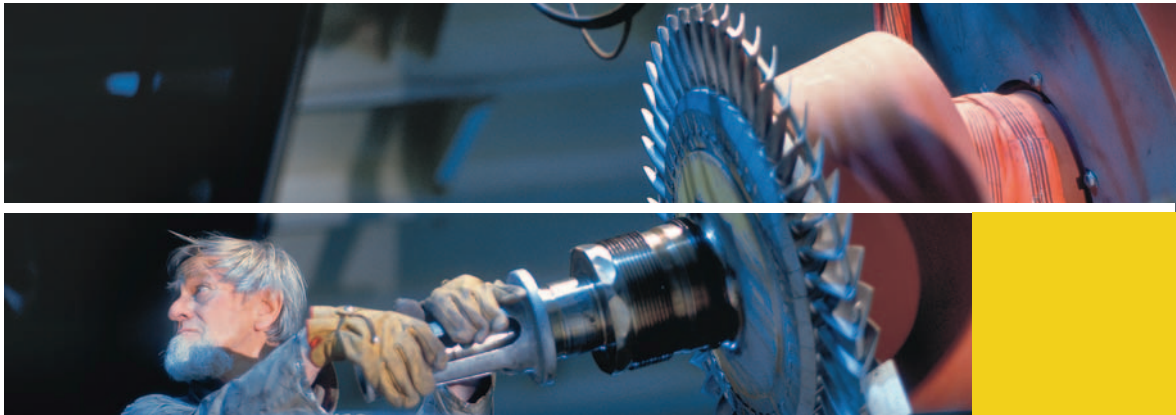

<b>Important when installing a new bearing on the VTR</b>	<b>3</b>
<b>Important when mounting RR impeller wheels</b>	<b>4</b>
<b>Delayed flow in gear-type oil pumps</b>	<b>5</b>
<b>The importance of cleaning during operation</b>	<b>6</b>
<b>The importance of cleaning when overhauling</b>	<b>7</b>
<b>Cleaning turbochargers in operation</b>	<b>8</b>
<b>Oil loss in the oil chamber on the compressor side</b>	<b>14</b>
<b>The two most important clearances</b>	<b>15</b>
<b>True running of the gear oil and centrifugal oil pumps</b>	<b>16</b>
<b>A harmless accumulation of particles</b>	<b>17</b>
<b>Erosion of turbocharger components</b>	<b>18</b>
<b>How to install bearings with gear oil pumps</b>	<b>20</b>
<b>Checking oil levels in VTRs with internal lubrication systems</b>	<b>22</b>
<b>Reconditioning of bearings and pumps</b>	<b>24</b>
<b>Tightening the ring nut at the turbine end</b>	<b>26</b>
<b>The LA36 / LA70 bearing generation</b>	<b>27</b>
<b>Lubricating oil for turbochargers</b>	<b>28</b>
<b>Silencers – disassembling and assembling</b>	<b>30</b>
<b>Broken protection sleeves can damage blades</b>	<b>31</b>
<b>Cleaning TPS filter-silencer parts</b>	<b>32</b>
<b>Emergency operation of turbochargers</b>	<b>34</b>
<b>Turbine washing – the right way</b>	<b>35</b>
<b>Early warning of inducer wheel failure</b>	<b>36</b>
<b>Engine performance deterioration after turbocharger overhauls?</b>	<b>37</b>
<b>V-clamp connections on TPS turbochargers</b>	<b>39</b>
<b>Don't worry about dry cleaning!</b>	<b>40</b>
<b>Cleaning a turbocharger's turbine – when and why</b>	<b>41</b>
<b>Is your engine room turbocharger service friendly?</b>	<b>43</b>

## Important when installing a new bearing on the VTR

Turbo Magazine 1/90

To avoid fretting, always apply white  $\text{MoS}_2$  lubricating paste (e.g. "Molycote D or DX") to the thread at the end of the shaft, to the bearing journals and to the front contact surface of the ring nut.

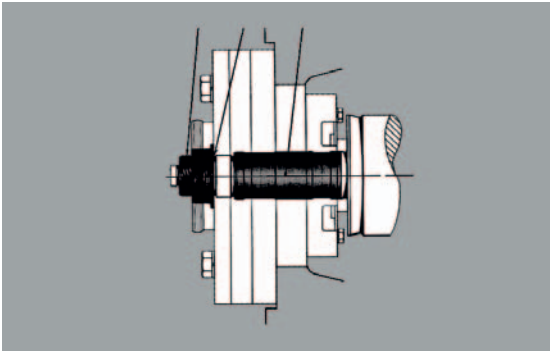
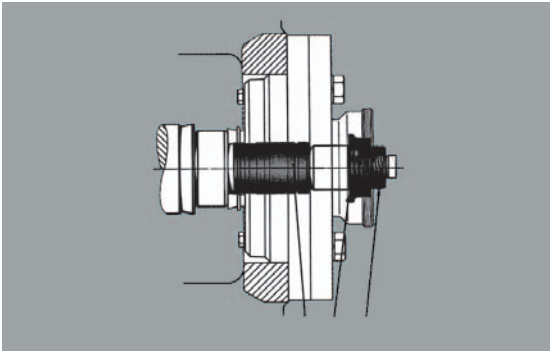

Coat with Molycote D or DX

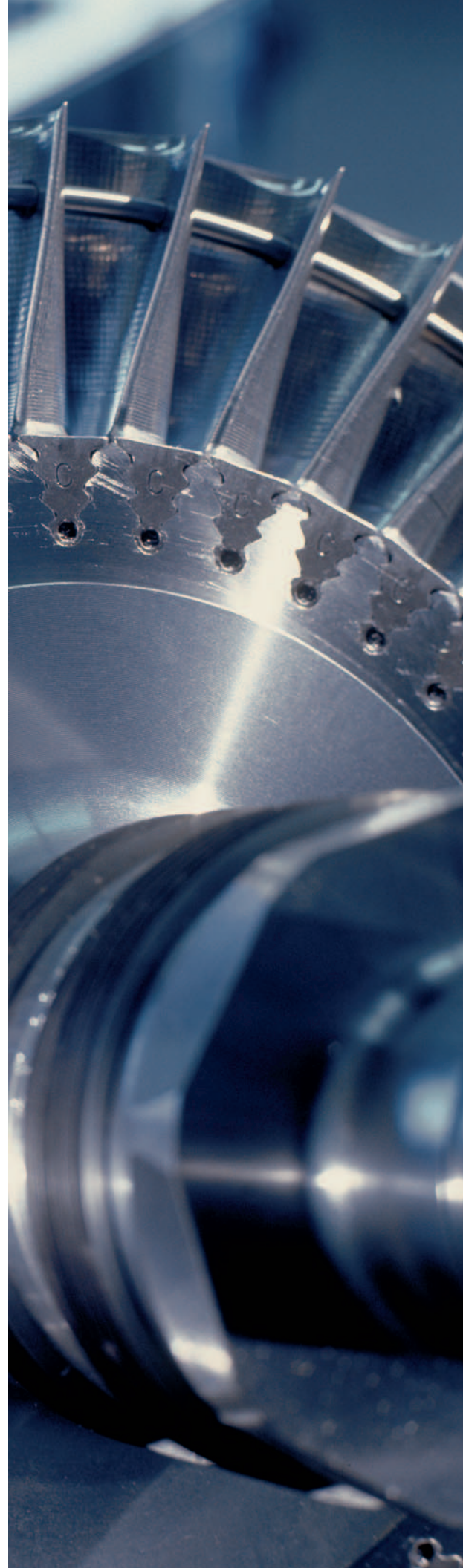

## Important when mounting RR impeller wheels

Turbo Magazine 1/91

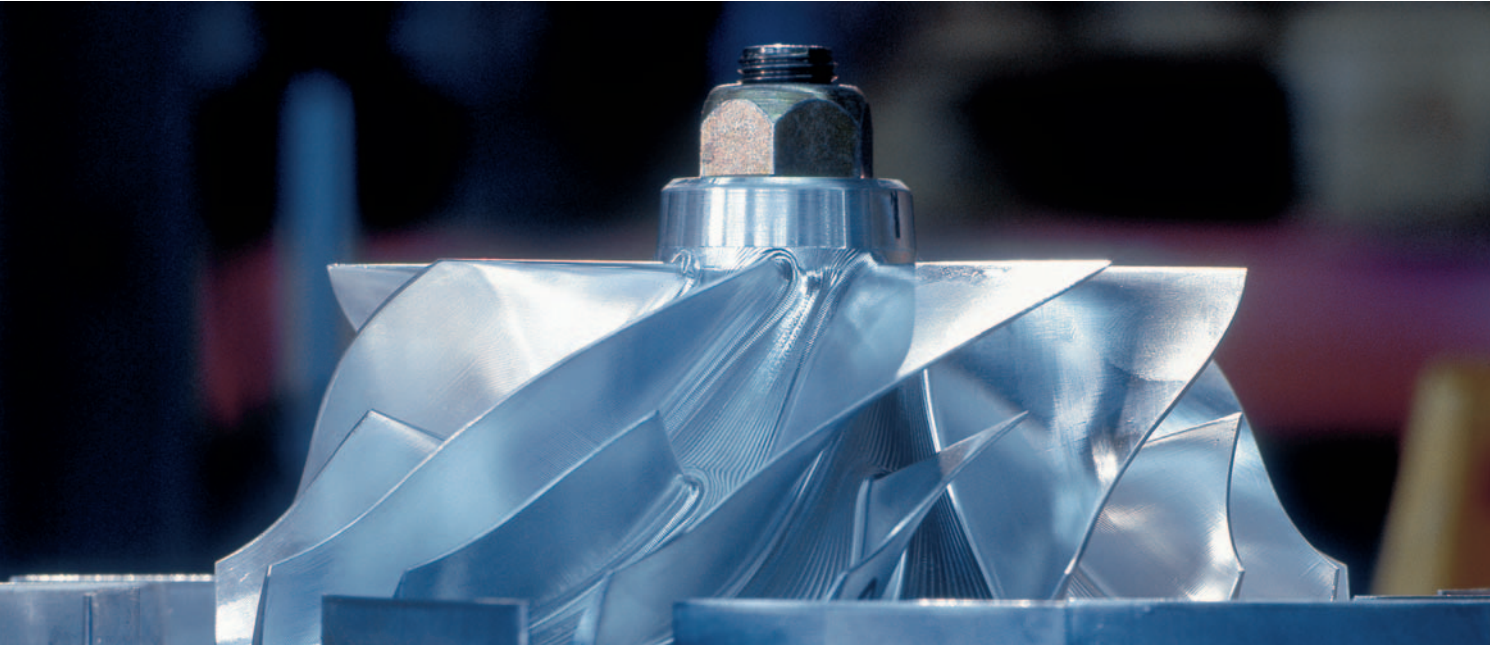

To avoid serious damage to the thread at the shaft ends when mounting the impeller wheel on turbochargers of type RR 131, RR 151, RR 153, RR 181 and RR 221, never use Molycote or any other lubricant, since the shaft end nut must be torqued with an exact tightening torque.

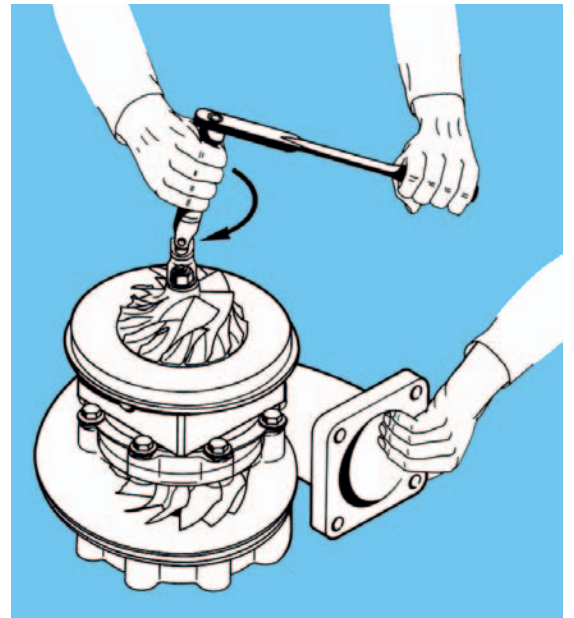



# Delayed flow in gear-type oil pumps (VTR 454 – 714, VTR 400/1 – 750/1)

Turbo Magazine 1/92

It is reported from time to time that gear-type oil pumps on VTR turbochargers do not supply any oil. These pumps have been thoroughly checked at the Baden works, and no faults have ever been found. All the pumps supplied oil as normal, beginning already at very low speed.

To function properly, the pumps body must always be filled with lubeoil. Therefore, before a pump is fitted to the turbocharger it must be primed before the bearing cover is fitted (*see picture on the right*).

When refilling with lubeoil, also make sure that the oil flows over the pump head. Special attention must be paid when using extension pipes or hoses in order not to push them too far inside.

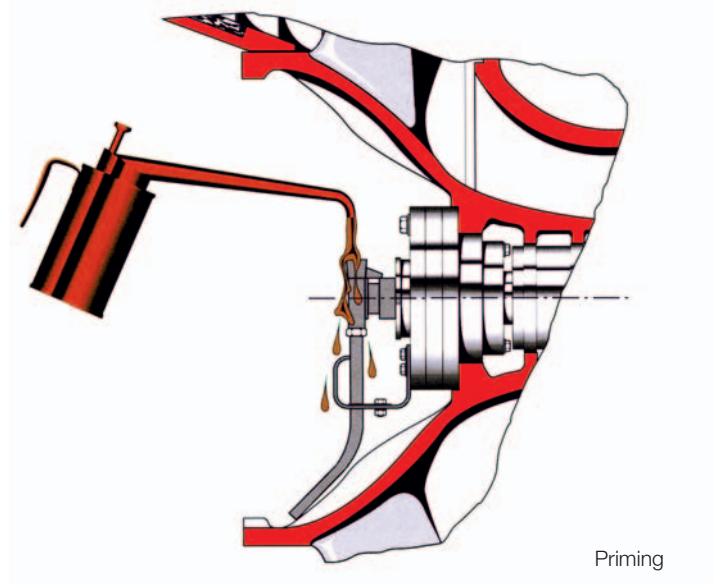

We also recommend that gear oil pumps be checked for tightness and proper functioning every 16,000 running hours in one of our service stations.

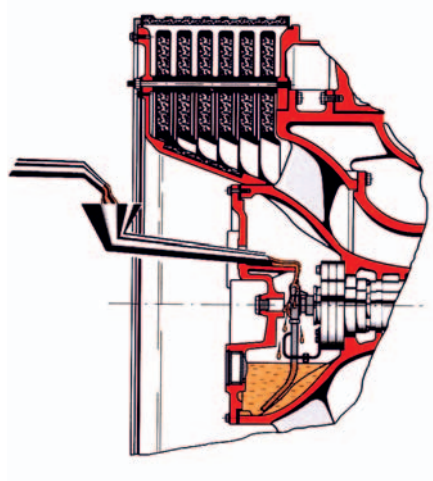

Correct

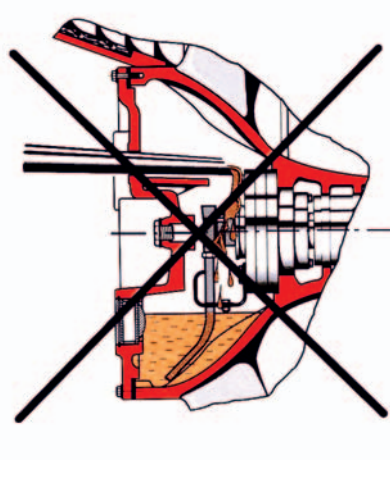

Wrong

**Compressor (1)**

Compressor pollution depends on how clean the incoming air is. The filters themselves are not capable of removing fine particles of soot or oil vapour, making it very important to seal leaking exhaust pipes and prevent oil losses. Besides affecting the efficiency, the layer of soot on the compressor contains sulphur, which has a corrosive effect on the aluminium alloy and can lead to a considerable reduction in the fatigue resistance of the inducer and compressor wheels.

Chemical aids (i.e. solvents) are not necessary for cleaning during operation. Our water injection method is based on the mechanical effect of impinging droplets of water. The water has to be injected with the turbocharger running at the highest possible speed. If solvents were to be used, the speed would have to be lower and the solvent injected for a longer time to have any effect.

**Turbine (2)**

When heavy fuel is used the nozzle vanes and turbine blades become dirty due to combustion residue and, though to a far smaller extent, the additives in the lubricating oil. Apart from a very thin coating of additives, turbochargers operating on engines using diesel oil show no signs of dirt deposits. When engines use heavy oil it is necessary to be able to clean the turbines during operation. Depending on the composition of the heavy fuel used and the quality of the combustion, such cleaning of the turbines will have to be carried out more or less frequently. For the turbine we recommend wet cleaning (water injection) as well as dry cleaning (granulate).

We continue to recommend wet cleaning for installations where the engine output can be reduced. The boost pressure has to be above 0.3 bar to prevent water entering the turbine end oil chamber and the exhaust gas temperature before turbine should not exceed 430 °C.

For further details please refer to our Technical Information Sheets or to “Cleaning turbochargers in operation” on page 8.

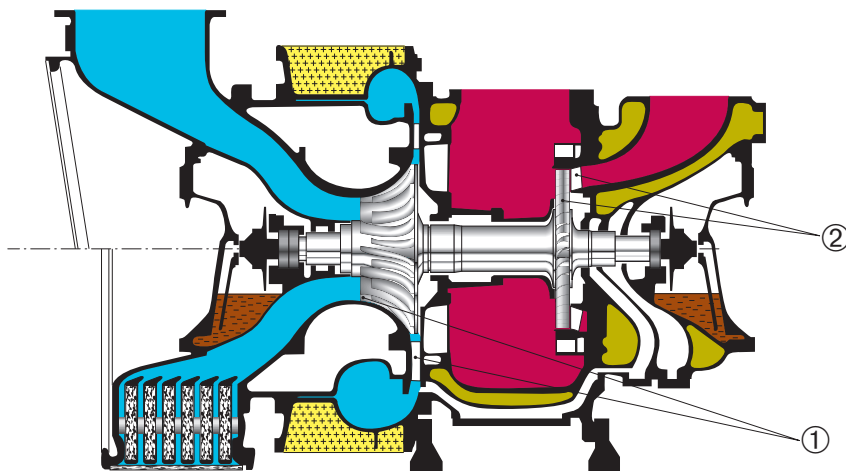

## The importance of cleaning when overhauling

Turbo Magazine 1/93

Article by Edy Wettstein/Hans Bärtschi

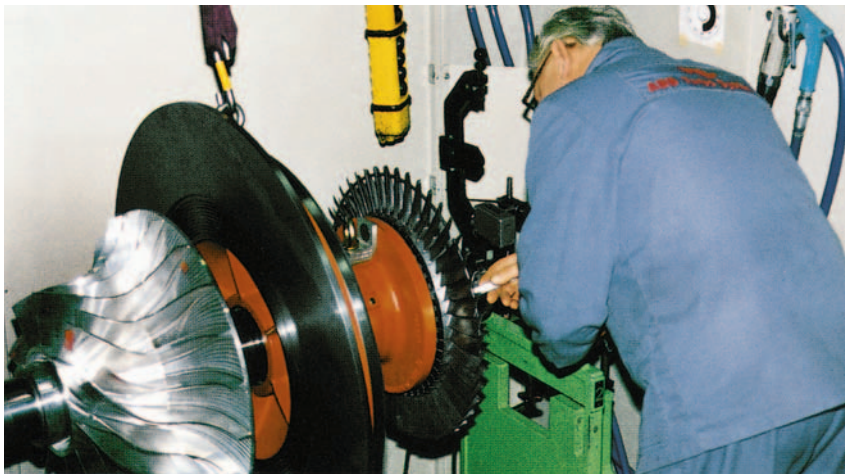

Balancing a rotor is a job for professionals

Even when cleaning is carried out regularly during operation, the rotor still has to be removed and cleaned according to a fixed schedule. From time to time it should be professionally rebalanced on a proper balancing machine to be sure that it runs smoothly and that bearing loads are minimized.

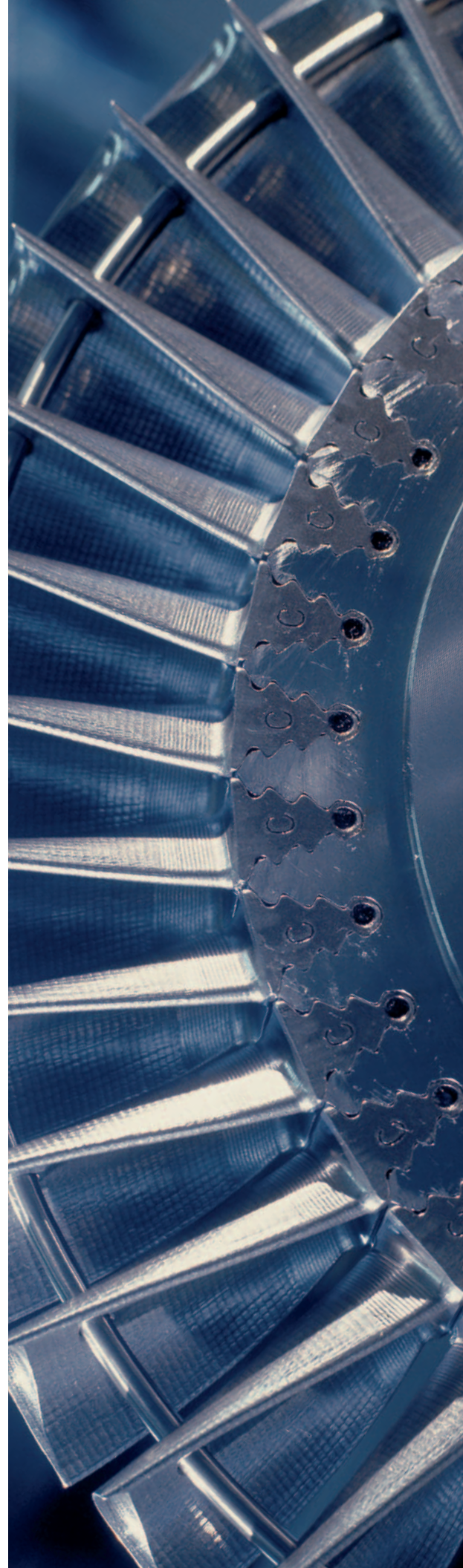



# Cleaning turbochargers in operation

Article by Hans Kronthaler

It is recommended that the compressor and turbine be cleaned with the turbocharger running. Periodic cleaning reduces or even prevents contamination, allowing significantly longer intervals between overhauls.

## Cleaning the compressor

The proposed cleaning method, carried out periodically, will prevent a thick layer of dirt from forming. A thick layer of dirt can cause a drop in efficiency and increased unbalance on the compressor side of the turbocharger, which could influence the lifetime of the bearings. The cleaning interval will depend on the environmental condition and on the installed air filter.

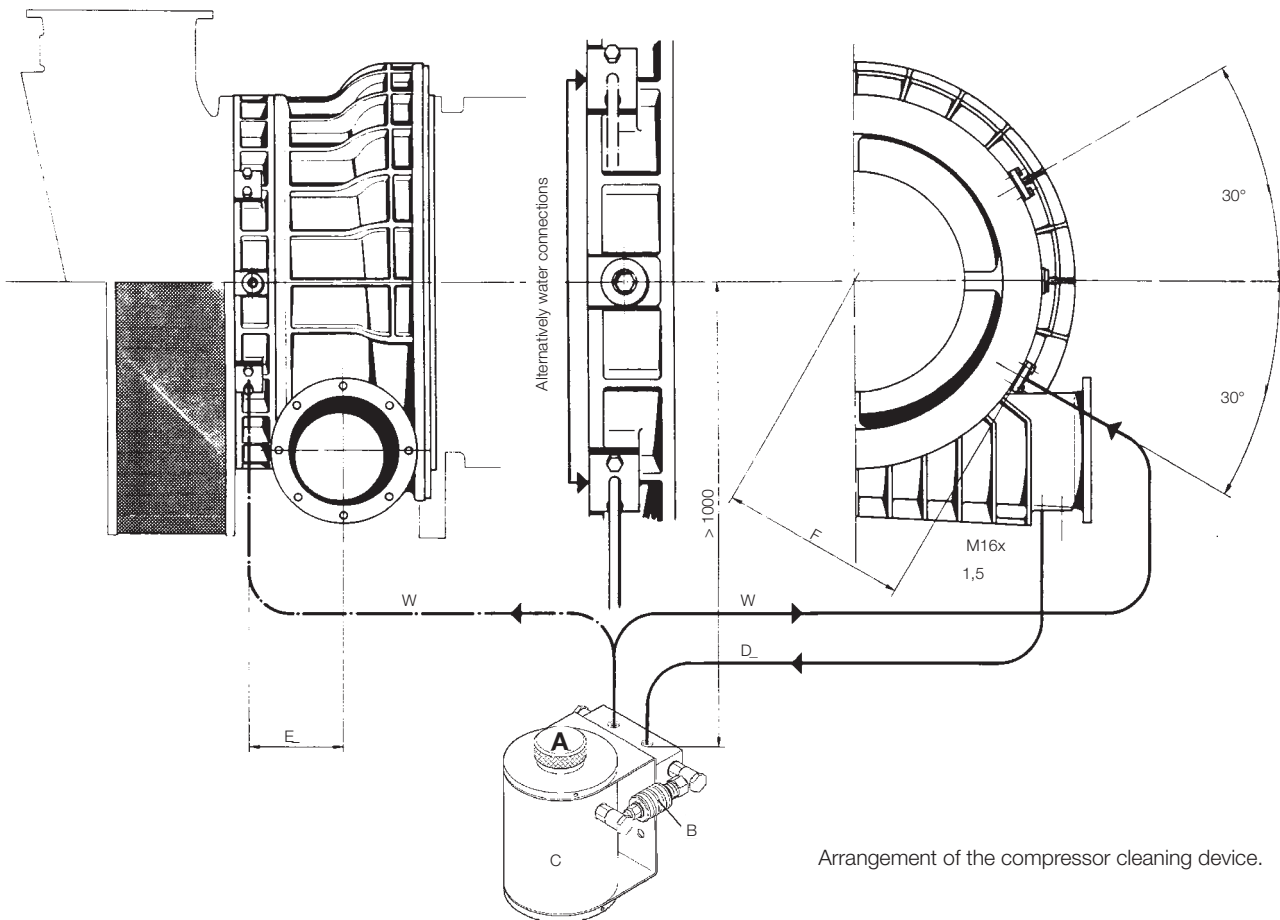

Arrangement of the compressor cleaning device.



The compressor wheel of the turbocharger can be cleaned during operation by spraying water into the air inlet casing. The dirt layer is removed by the impact of the injected water. Since the liquid does not act as a solvent there is no need to add chemicals. The use of salt-water is not allowed, as this would cause corrosion of the aluminium compressor wheel and the engine. Water is injected from a water vessel that holds the required quantity of water. This water vessel can be either ordered together with the turbocharger or ordered separately.

**Procedure:**

- The best results are obtained by injecting water during full-load operation of the engine, i.e. when the turbocharger is running at full speed.
- The complete contents of the water vessel should be injected within 4 to 10 seconds.
- Successful cleaning is indicated by a change in the charge air or scavenging pressure, and in most cases by a drop in the exhaust gas temperature.
- If cleaning has not produced the desired results, it can be repeated after 10 minutes.
- The interval between compressor cleanings will depend on the condition of the turbocharger suction air. It can vary from 1 to 3 days of operation.

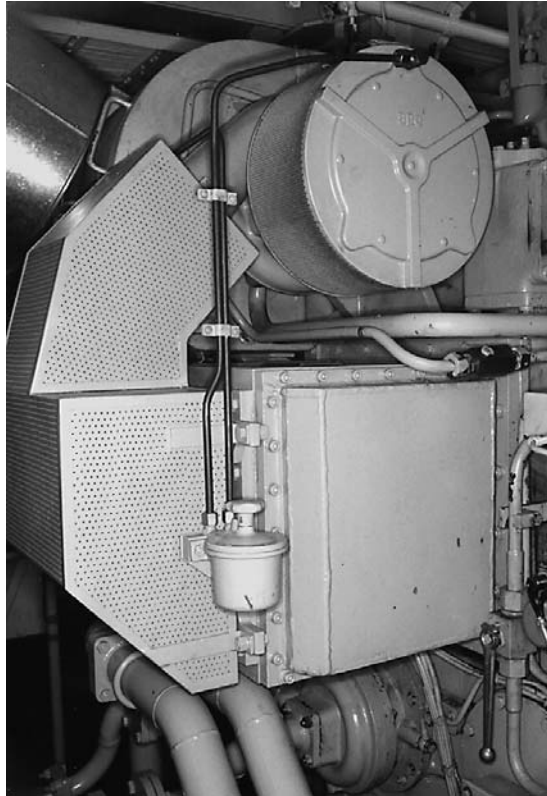

Installation of the compressor cleaning device for an ABB turbocharger of type RR.

## Cleaning turbochargers in operation (cont.)

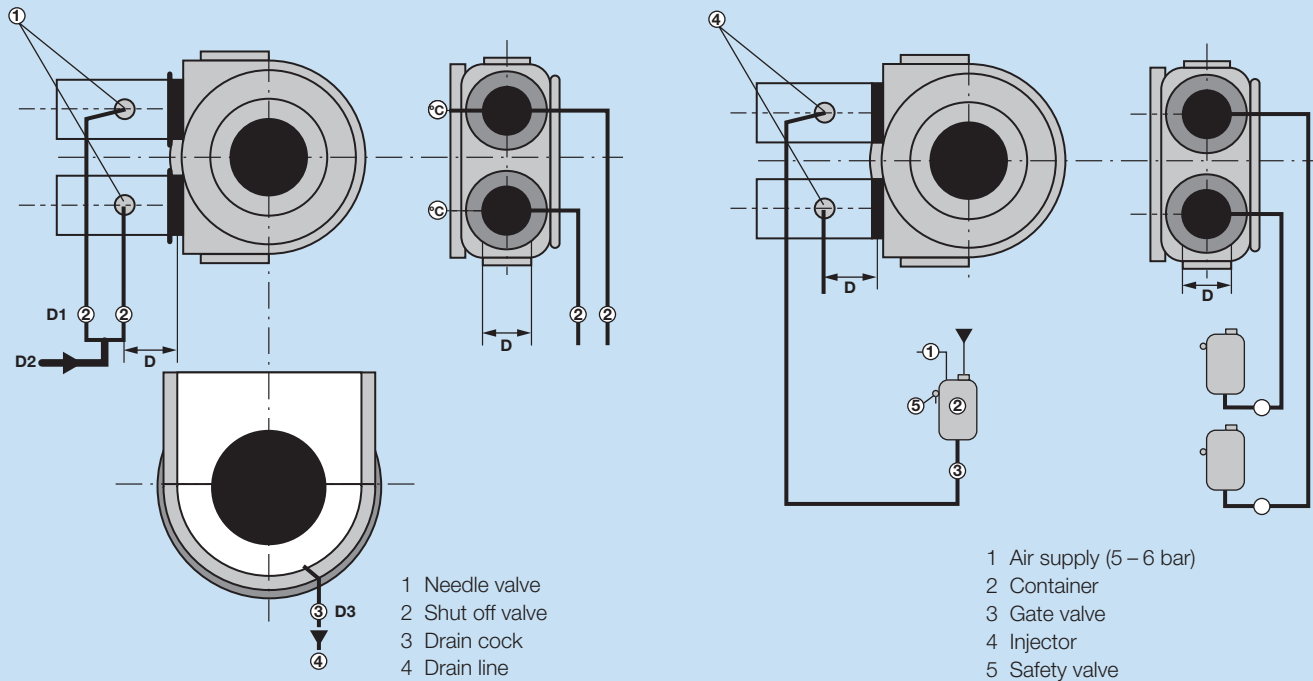

Typical wet cleaning installation. Gas inlet casing with 2 inlets.

Typical dry cleaning installation. Gas inlet casing with 2 inlets.

If a very thick layer has built up and it cannot be removed using the method described, it will be necessary to dismantle the turbocharger in order to clean the compressor side.

### Principle:

Since the dirt layer is removed by the kinetic energy of the water droplets, the engine has to be run at full load.

### Cleaning the turbine

The combustion of heavy fuel in diesel engines causes fouling of the turbine blades and nozzle ring. The result of this fouling is reduced turbine efficiency and engine performance as well as an increase in the exhaust gas temperature. Experience has shown that the contamination on the turbine side can be reduced by regular cleaning in operation, and that such cleaning allows longer intervals between turbocharger overhauls.



Some of the deposits have their origin in soot, molten ash, scale and unburned oil, partially burnt fuel and sodium vanadylvanadat. Investigations have shown that most of the residues are caused by the calcium in the lube oil reacting with the sulfur from the fuel to form calcium sulfate during the combustion process. The quantity of the deposits depends on the quality of the combustion, the fuel used, and the lube oil consumption. The frequency with which cleaning has to be carried out depends on the extent of the contamination on the turbine side.

**Two cleaning methods exist:**

- Wet cleaning (water injection)
- Dry cleaning (solid particle injection)

### Procedure for wet cleaning (2- and 4-stroke):

- The boost pressure has to be above 0.3 bar to prevent water entering the turbine end oil chamber.
- The exhaust gas temperature before turbine should not exceed 430 °C.
- The drain of the gas outlet has to be opened to drain the non evaporated water.
- The quantity of injected water will depend on the exhaust gas temperature, water pressure, size of the turbocharger and number of gas inlets. Details can be found in the engine builder's manual or in our instructions.
- The interval between turbine cleanings will depend on the combustion, the fuel used and the fuel oil consumption. It can vary from 1 to 20 days of operation.

### Principle:

The dirt layer on the turbine components is removed by thermal shock rather than the kinetic energy exerted by the water droplets.

### Procedure for dry cleaning (2-stroke only):

- The exhaust gas temperature before the turbine should not exceed 580 °C.
- The boost pressure has to be above 0.5 bar.
- Dry cleaning has to be carried out more often than water cleaning as it is only possible to remove thin layers of deposits. A cleaning interval of 1 to 2 days is recommended.
- To ensure effective mechanical cleaning, granulated dry cleaning media are best injected into the turbine at a high turbocharger speed.
- The quantity needed will vary from 0.2 l to 3 l, depending on the size of the turbocharger.
- Experience has shown that the best results are achieved with crushed nutshell or granulate.

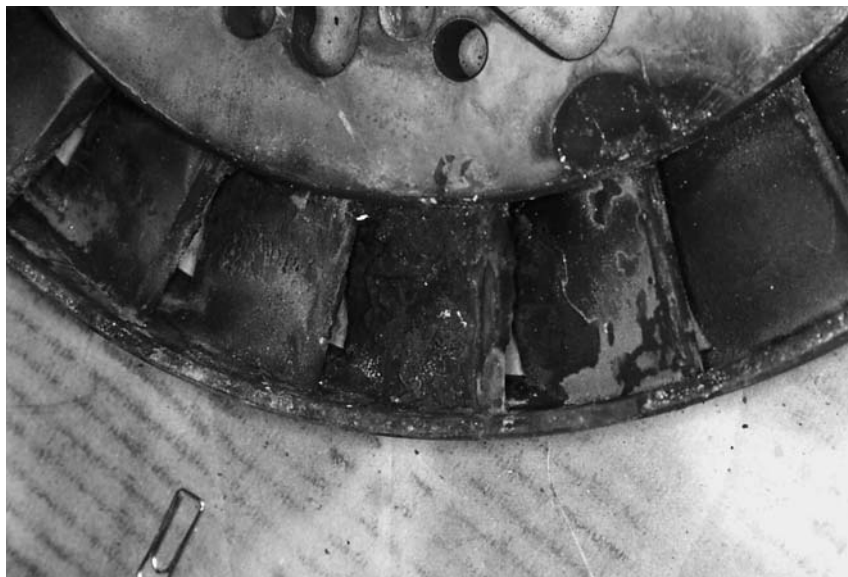

Dirty nozzle ring. Cleaning was not carried out according to our recommendations.



**Principle:**

The layer of deposits on the turbine components is removed by the kinetic energy of the granulate causing it to act as an abrasive.

Devices for both methods are usually supplied by the engine builder and are manufactured in accordance with our recommendations. Experience has shown a combination of the two to be very effective in some cases.

For further information, please contact your nearest ABB Turbocharger service station.



## Oil loss in the oil chamber on the compressor side

Turbo Magazine 1/94  
Article by Michael Alt

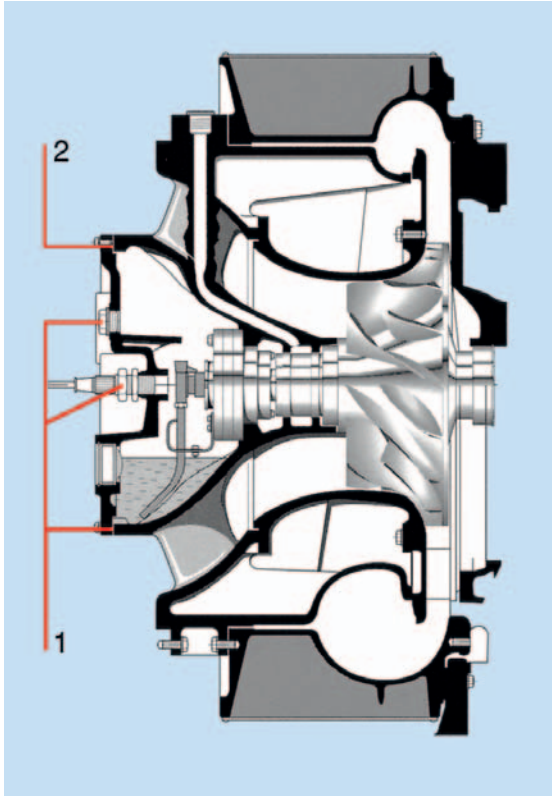

Reports are received from time to time about a sudden oil loss in the oil chamber on the compressor side. Investigations invariably show that this occurs either after removal of the oil space cover during a bearing change, after an oil change, or after speed control by means of the manual indicator.

The reason for the oil loss is easily explained. During normal running there is a slight underpressure in the oil chamber on the compressor side. If there is a leakage due to the plugs (1) not being properly tightened, or if a damaged gasket (2) is reused, the underpressure will not be maintained. Instead, there will be a flow of air from this leakage to the compressor wheel. This air flow entrains oil from the oil chamber, leading to the oil loss. We would therefore like to call your attention to the following: Before mounting the oil space cover, check the condition of the gasket. If there is any damage at all or you are in doubt about it, replace it. Also, after changing the oil tighten the plugs properly and make sure that a gasket is fitted. And when using the manual indicator for speed control, refit the respective plug without any long delay. If the gauge glass is damaged, replace it as soon as possible.

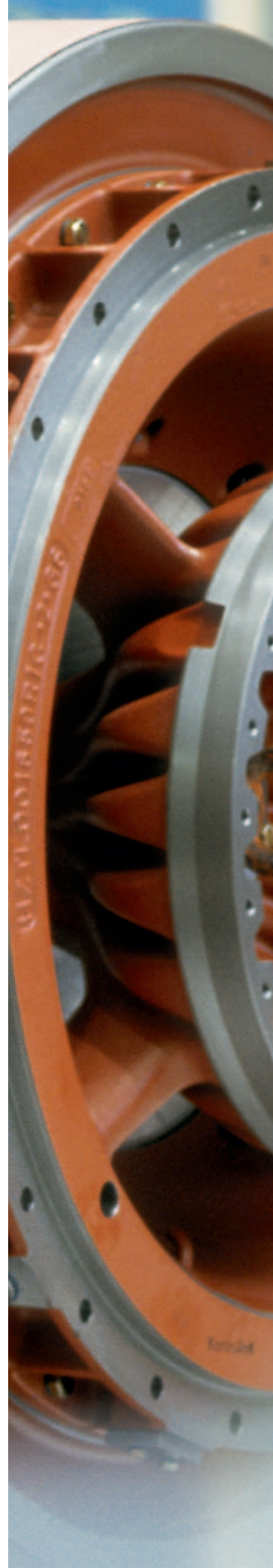



## The two most important clearances

Turbo Magazine 2/94  
Article by Hans Bärtschi

When rotor clearances are out of tolerance, the rotor will not be able to rotate and there will be a risk of breakdown and serious damage. Exact measurement of the clearances is necessary in order to determine that the rotor is in its working position:

Clearances which should be measured when disassembling and assembling:

- Measure dimension K (see Fig. 1).
- Withdraw bearing about 5 – 6 mm.
- Push the rotor towards the compressor.
- Measure dimension K1 (see Fig. 2).
- Pull the rotor towards the turbine.
- Measure dimension K2 (see Fig. 3).

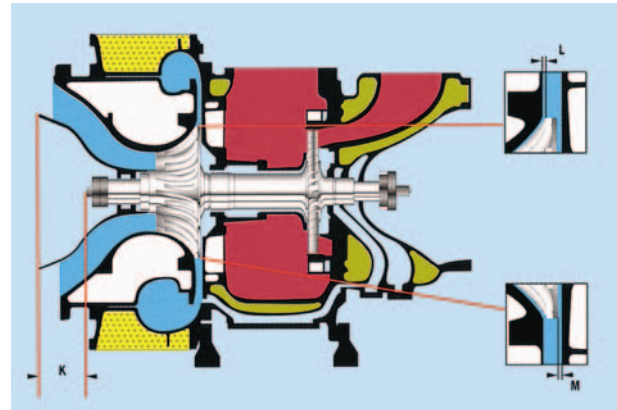

Fig. 1

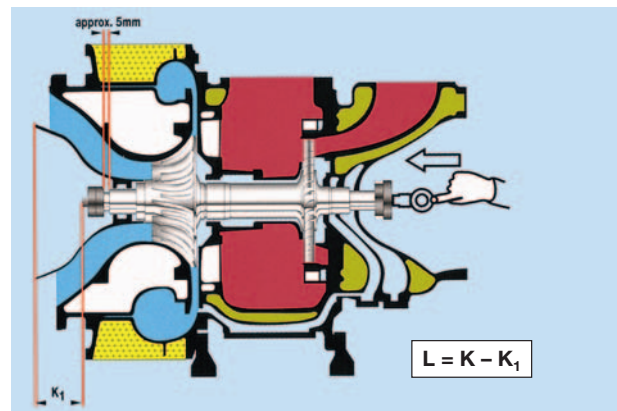

Fig. 2

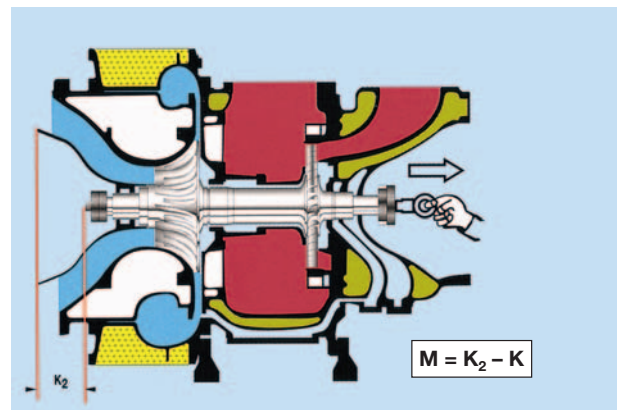
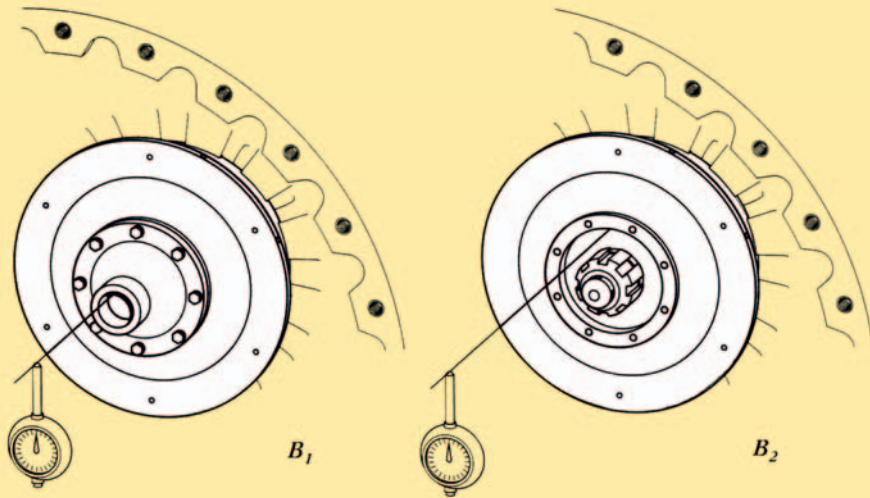
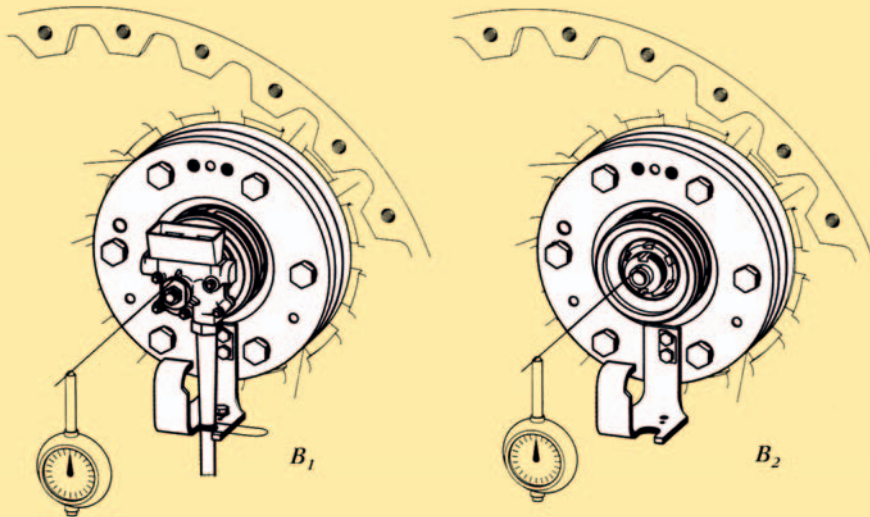

Fig. 3



VTR	B <sub>1</sub>	B <sub>2</sub>
184	0.00...0.04	0.00...0.03
214	0.00...0.04	0.00...0.03
254	0.00...0.04	0.00...0.03
304	0.00...0.05	0.00...0.03
354	0.00...0.06	0.00...0.04
160/161	0.00...0.03	0.00...0.02
200/201	0.00...0.04	0.00...0.03
250/251	0.00...0.05	0.00...0.03
320/321	0.00...0.06	0.00...0.04



VTR	B <sub>1</sub>	B <sub>2</sub>
454	0.00...0.02	0.00...0.01
564	0.00...0.02	0.00...0.01
714	0.00...0.02	0.00...0.01
400/401	0.00...0.02	0.00...0.01
500/501-2	0.00...0.02	0.00...0.01
630/631-1	0.00...0.02	0.00...0.01
750/750/751-1	0.00...0.02	0.00...0.01

In order to minimise wear and to ensure optimum lubrication of the bearings, the centrifuge and nipple should be fitted in such a way that the given tolerances are not exceeded. For the right tolerances, refer to the Working Instruc-

tion, the Operation Manual or the table above. If tolerances exceed, dismantle, clean all axial contact surfaces, turn centrifuge and/or nipple by 180°, reinstall and check again.



## A harmless accumulation of particles

Turbo Magazine 2/95  
Article by Edy Wettstein

Some operators of VTR turbochargers worry when they see a grey-colored cone growing below the opening of the gear oil suction pump. There is no need to. It is an utterly harmless phenomenon.

A small cone-shaped accumulation of sludge and oil-aging residues, mixed with abrasion particles of steel, aluminum and bronze originating from the casing, pump and bearing damping parts, often forms just below the opening of the gear oil pump suction pipe. The residues accumulate at just this spot due to the suction flow current of the working gear oil pump. Most particles just remain there, but some are sucked through the pump and injected into the centrifuge, which also works as a dirt separator, where they are finally collected and can be removed during a standard overhaul.

The residues are harmless and have no negative influence on safety or running behavior. No measures need to be taken to reduce or restrict their formation.

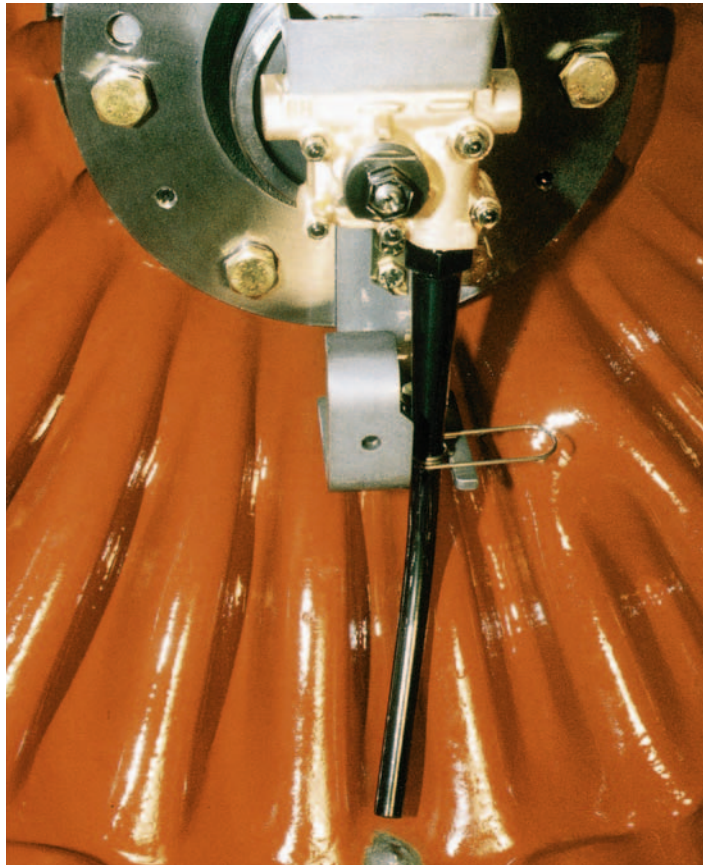

Such a sludge/particle mixture can grow to approximately  $\frac{1}{4}$  of a  $\text{cm}^3$ . Its size will depend on the following:

- Level of vibration
- Newly installed parts
- Cleanness of the oil chamber
- Purity and quality of the lube oil
- Number of running hours

Erosion of nozzle and cover rings can be a problem, particularly for installations that run on heavy fuel oil. If left unattended, the erosion will eventually lead to a drop in turbocharger efficiency and to the premature replacement of parts.

This kind of erosion is caused by particles being formed during the combustion process and conveyed to the turbocharger by the exhaust gas. The quantity and size of the particles depend on a number of factors, ranging from the properties of the fuel to engine operation.

Factors with a major influence on particle formation are the fuel property CCAI (Calculated Carbon Aromaticity Index) and the asphaltene, vanadium and sulphur content of the fuel oil.



Also significant are the fuel oil preheating, compression ratio, injection equipment wear and engine load. The engine part load, in particular, plays a major role in the formation of the larger particles causing erosion (see figure).

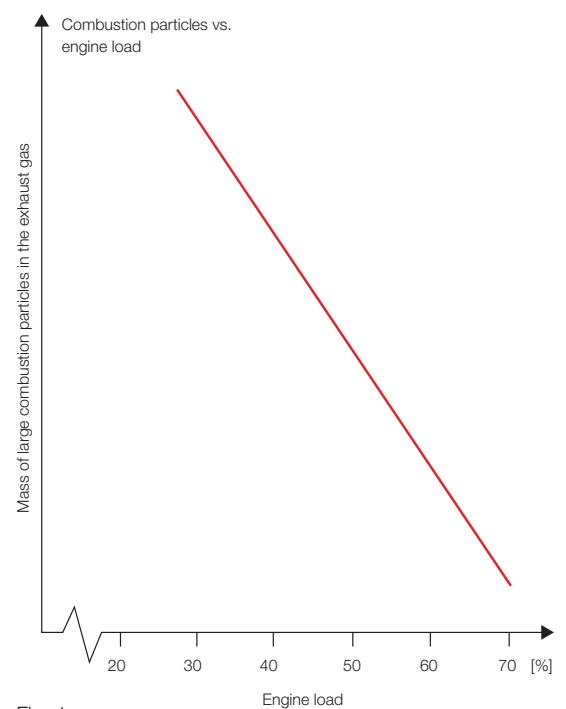

Fig. 1

## Recommendations

The best way to avoid erosion is to restrict the formation of particles.

- Start by ensuring that your engine is top fit.
- Have a fuel oil analysis performed by a noted laboratory. This will help you to avoid fuels with inferior properties.
- If you are running more than one generator or auxiliary engine, avoid running them for prolonged periods at low loads (*Fig. 1*). If possible, run fewer generators at higher loads.

If erosion cannot be avoided, you may be able to fit erosion-resistant coated nozzle and cover rings. These are available for several different types and sizes of ABB turbocharger. Contact your nearest ABB service station for details.

Note, too, that a leaking turbine-washing water valve also erodes your turbocharger!



## How to install bearings with gear oil pumps

Turbo Magazine 2/96  
Article by Bruno Meier

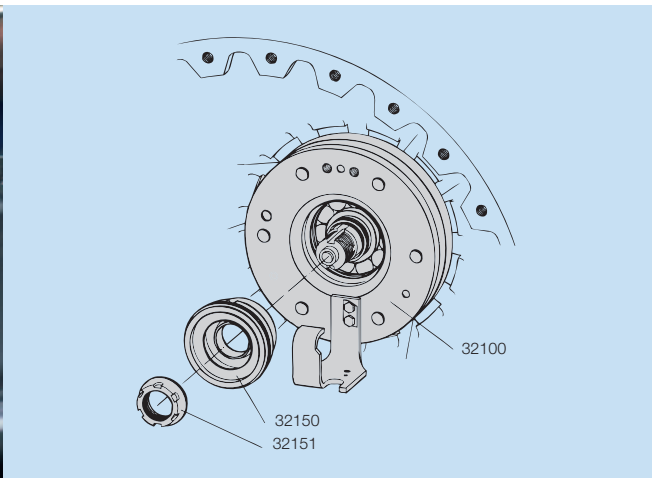

We have found in the past that when installing bearings, some customers use the hex.-head screws to push the bearings into position. This practice causes damage to the bearings and may even result in breakdowns!

To correctly install the bearings, follow the steps below. For more details, see chapter 5 of the operation manual “Disassembly and Assembly”.

### First step:

- Use only original parts from authorized ABB Turbo Systems service stations.
- Clean the bearing space before installing the new bearing.
- Before fitting the new bearing, clean the shaft end thoroughly.
- Coat with MOLYCOTE D or DX (white).
- Push the bearing (32100) in as far as possible.
- Fit the centrifuge (32150).
- Coat threads and contact surface of the ring nut (32151) with MOLYCOTE D or DX (white).
- Screw on the ring nut (32151) by hand as far as possible.



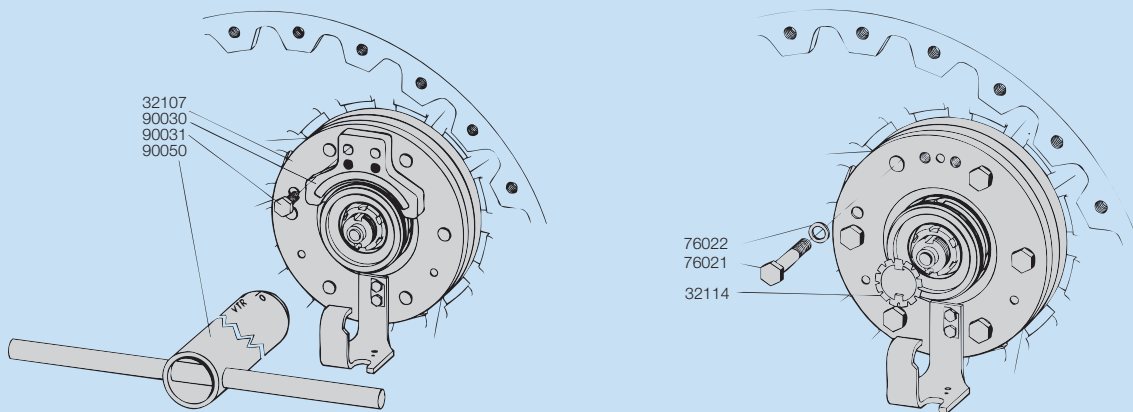

### Second step:

- Fit the fixing tool (90030) using the hex.-head screws (90031).
- Press the bearing and the centrifuge with the box spanner (90050) and the shaft-end nut for max. two turns onto the shaft.
- Check measurements K1 and K2.
- Then press the bearing and the centrifuge with the box spanner (90050) and the shaft-end nut onto the shaft shoulder.
- Release the ring nut using the box spanner.
- Take off the fixing tool (90030) with the hex.-head screws (90031).
- Tighten the ring nut with the required torque (see Operating Manual).

### Third step:

- Fix the hex.-head screws (76021) and washer with the required torque (see Operating Manual).
- Check measurement K.
- Check the true run at the shaft end and pump (for deflection values, see Operating Manual).

We occasionally receive questions or complaints from operators of diesel engines concerning:

**Unreliable readings of the lubricating oil levels of VTR-type ABB turbochargers during operation**

The reasons are:

- Precise readings of oil levels are only possible when the engine and turbocharger are at a complete standstill!
- Caution: Refill the lubricating oil only as far as the top of the circle or to the upper mark on the gauge glass.

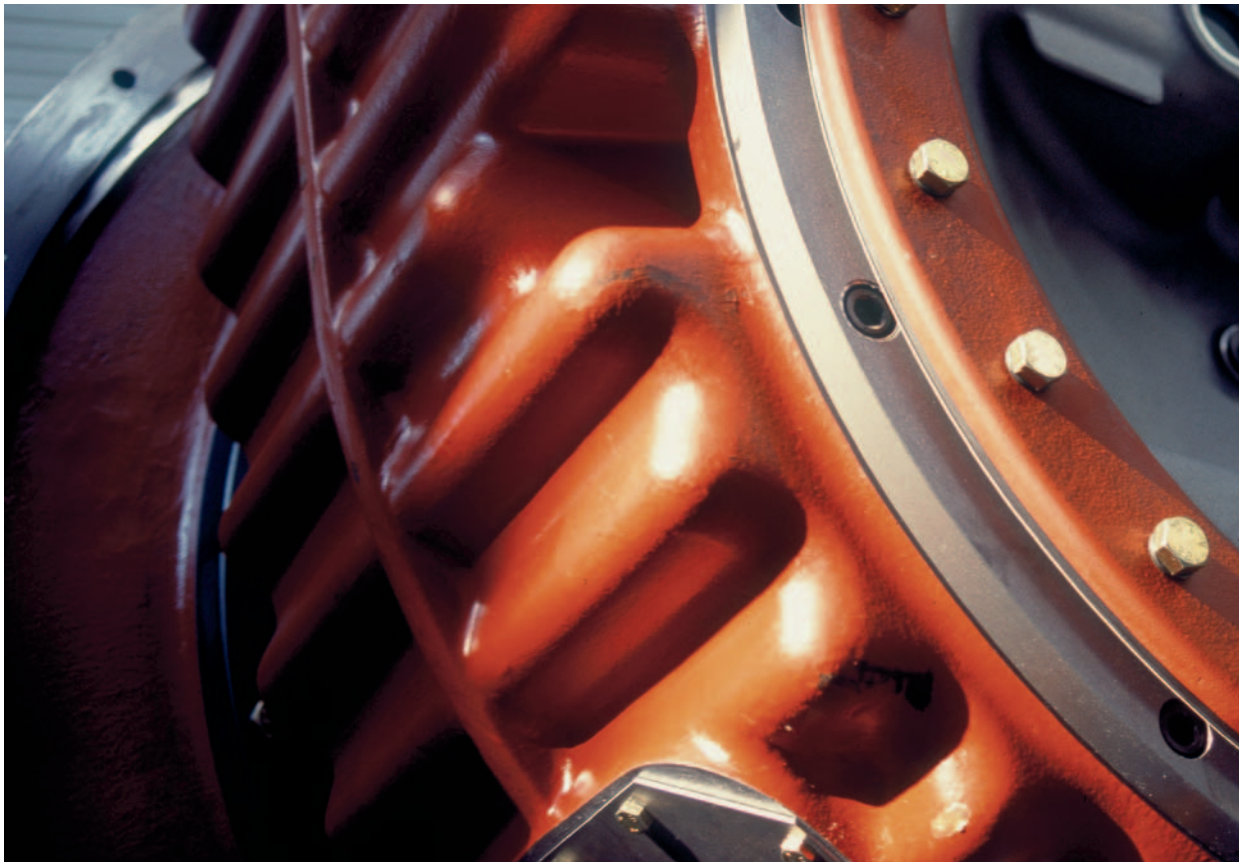
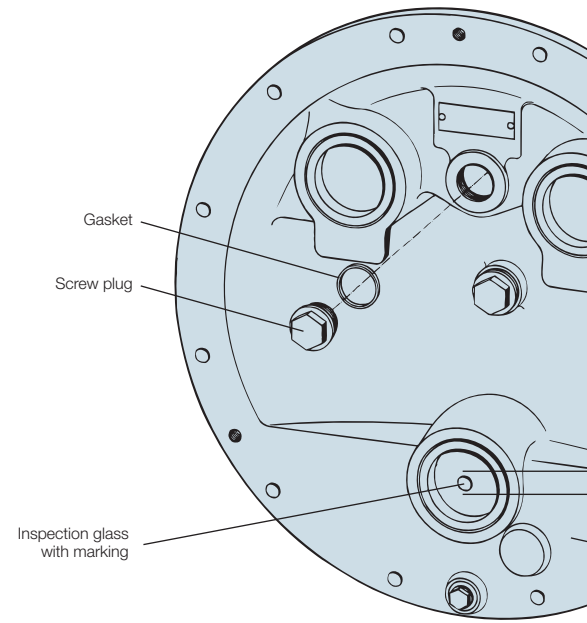

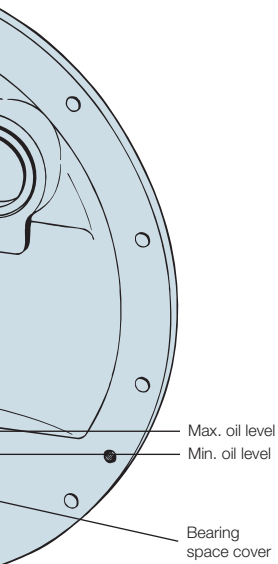

### **Dropping of oil levels just after new oil has been filled and the engine has been restarted**

The reasons are:

- When the turbocharger is in operation, some of the oil in the bearing chambers circulates in the internal oil feeding system, thereby causing lower oil levels in the oil sump (and not “oil losses”, as is sometimes suggested!).
- Oil losses will, however, occur when the operator decides to top up with oil during operation and removes the screw plug of the oil inlet.
- Note: This “short cut” endangers the safe operation of the turbocharger and is therefore not allowed!

### **Foaming of oil in the bearing chambers**

The reasons are:

- Excessive foaming may be an indication of contaminated oil. Two or three oil changes will usually correct the situation.
- Foaming is harmless as long as it does not cause loss of oil and the oil level can still be seen!
- If the foam layer is thicker than about 8–10 mm and the oil level can no longer be observed through the gauge glass, the engine has to be stopped as soon as possible and an oil change carried out on the turbocharger.



Did you know that you can send your old VTR bearings and gear oil pumps for reconditioning after their operational service life has expired?

The operational service life is the full period of operation, given in hours, specified for a bearing or pump. After this period, the bearing or pump has to be checked, reconditioned, reset and tested before it can be put back into service for another full period of operation.

The service lives of bearings and pumps depend on the bearing type and the type of installation. Gear oil pumps, for example, have a set operational service life of 16,000 h for all types, specifications and sizes.

In the case of roller contact bearings, the operational service life depends on the type and specification of the bearing, on the temperature and oil quality, and also on the type of operation and installation. It usually lies between 8,000 h and a maximum of 16,000 h, after which the bearings have to be reconditioned.

ABB has equipped 19 of its total of over 90 service centers around the globe especially for such work. Each of these 19 centers has a dedicated crew trained specially in bearing and pump reconditioning. All ABB service centers adhere to strict guidelines and procedures, while regular audits are carried out by headquarters. The centers also benefit from the use of standardized high-precision equipment, tools and testing machines.



● ABB service stations

Reconditioning means that the races or plain bearing body will be entirely renewed in every case, while the remaining parts, such as the casings flanges and bushes, will be thoroughly cleaned and reworked when necessary. All the parts are then carefully measured and checked on the basis of the given specifications, dimensions and procedures. In addition to carrying out a very detailed inspection of the relevant parts, it is essential for reliable operation that the axial clearance “S” and the axial position “A” be set precisely.





● ABB reconditioning centers for bearings and pumps

ABB guarantees the same operational life for an ABB-reconditioned bearing or pump as for an all-new unit.

Save money and send your old bearings and pumps to one of the specialized service centers listed aside for a professional reconditioning job.

Wrap your old bearings and pumps carefully and protect them with some oil when sending them for reconditioning, since credit notes can only be given for reconditionable parts, and not for parts that are completely corroded or broken!

### ABB reconditioning centers for bearings and pumps

- Sydney, Australia
- Santos, Brazil
- Montreal, Canada
- Marseille, France
- Hamburg, Germany
- Telford, Great Britain
- Piraeus, Greece
- Mumbai, India
- Genova, Italy
- Rotterdam, Netherlands
- Oporto, Portugal
- Singapore, Singapore
- Cape Town, South Africa
- Busan, South Korea
- Madrid, Spain
- Gothenburg, Sweden
- Istanbul, Turkey
- Dubai, UAE
- Miami, USA

Situation as of 2008

## Tightening the ring nut at the turbine end

Turbo Magazine 1/98  
Article by Hans Baertschi

Experience with the VTR 454-714 has shown that a tightening angle equal to  $\frac{2}{3}$  of the angle of rotation  $\alpha$  is sufficient when tightening the shaft-end nut at the turbine end. When tightening, use the copper mandrel (90048) as the striking tool.

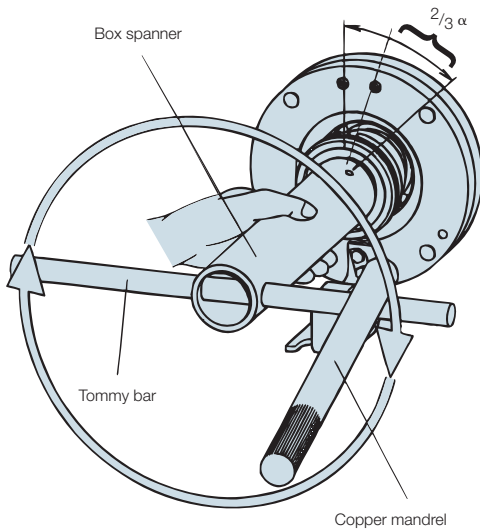

VTR 454 - 714

### Procedure

- Position the box spanner and make a mark on the centrifuge in the radial extension of the "O" mark (*see sketch*).
- Tighten the shaft-end nut by striking the tommy bar with the copper mandrel until  $\frac{2}{3}$  of the second mark on the box spanner coincides with the mark on the centrifuge.

Note: To ensure more concentric running, turn the rotor  $180^\circ$  with the box spanner and ring nut between each blow with the mandrel.

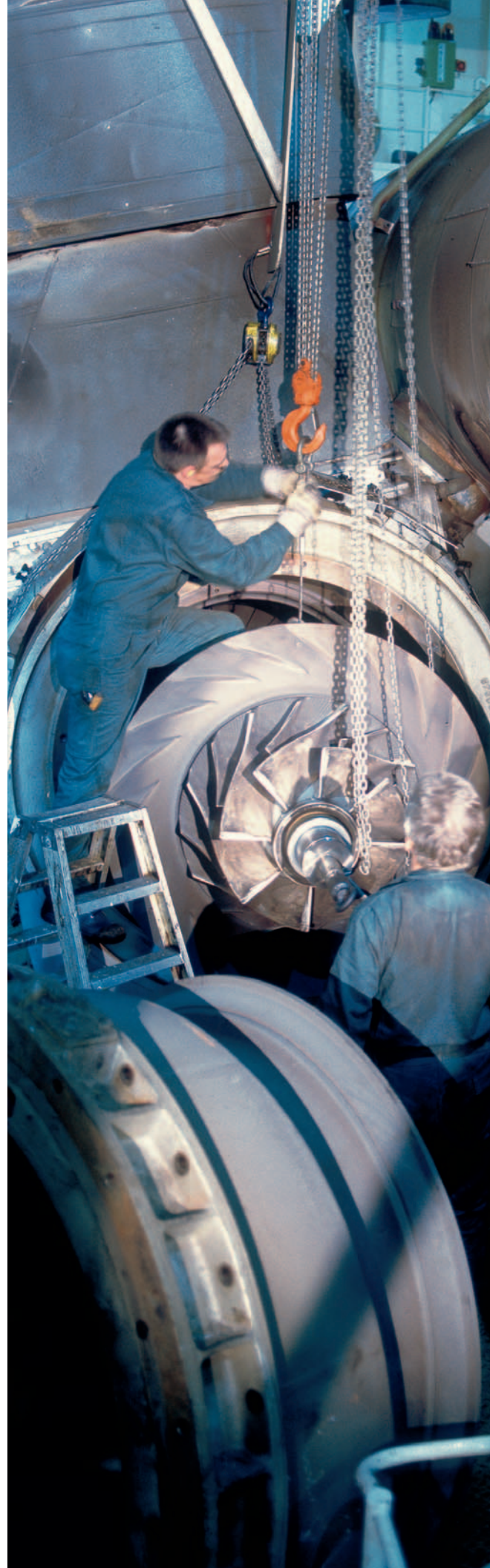



## The LA36 / LA70 bearing generation

Turbo Magazine 2/98  
Article by Karl-Jakob Brem

The antifriction bearings (LA36/LA70) are made of a special heat- and wear-resistant material, with the ball retaining cages made of high strength steel and centered on both sides. The bearing generation is the result of a very close co-operation with our bearing supplier. From the start, it has performed excellently and its reliability has proved outstanding. Based on these results, ABB has decided to install this bearing generation in all production turbochargers. In order to let the turbocharger operator participate in this success all bearings supplied from ABB for any VTR..4 turbocharger are of the new design since 1998, even the reconditioned bearings. Take advantage of this success and ask for the new bearing LA36 or LA70.

LA36 is our designation for the bearing assembly used in the VTR564 families and smaller, while LA70 is the designation for the VTR714 bearing assembly available as an option also for VTR454 and VTR564. Why two designations? The LA70 represents a step into the future. Apart from the described features of the new bearing, it also has a revolutionary bearing support. The special geometry of the support is able to compensate and absorb possible inclinations of the support flange. The squeeze film damper (no wear!) provides excellent damping of shaft movements – the result of an oil film between the bearing flange

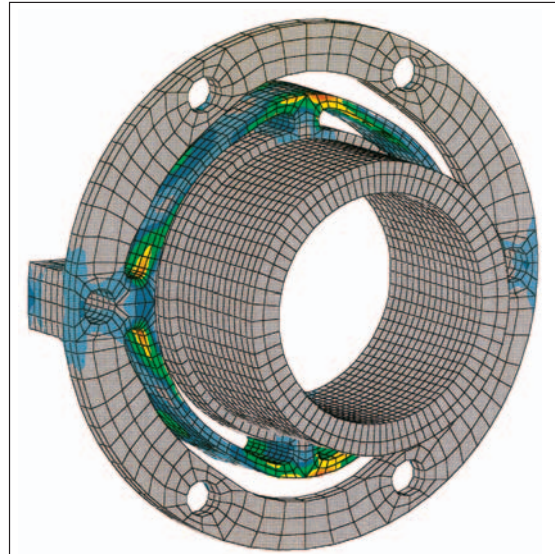

### The tip for the operator!

The LA36 / LA70 bearing generation leads to a slight increase in oil temperature at the same operating point compared to older style bearings. This is the result of the better heat exchange achieved with the new bearing geometry. A higher lubrication oil temperature causes the oil to age faster, often evidenced by rapid discoloration of the oil. It is therefore recommended that a lubrication oil of the latest generation (e.g. synthetic oils) be used with the new bearings. Any ABB Service Station can provide you with updated information on the most suitable oils.

and the support flange. This considerably reduces the forces on the bearing, compared with the former radial damping shims. The optimized geometry allows a better definition of the loads acting on the bearings, thus eliminating any unpredictable load conditions. The same support is also available on the turbine side (TA07) in combination with the roller bearing.

<b>VTR</b>	<b>184</b>	<b>214</b>	<b>254</b>	<b>304</b>	<b>354</b>	<b>454</b>	<b>564</b>	<b>714</b>
<b><math>n_{B_{max}}</math> [1/s]</b>	<b>726</b>	<b>611</b>	<b>514</b>	<b>433</b>	<b>364</b>	<b>289</b>	<b>230</b>	<b>183</b>

Turbocharger speed at 100 % engine load  $n_{B_{max}}$

Due to the fact that oil temperatures are higher with bearing types LA36/TA04 and LA70/TA07 than with the LA34 bearings, we strongly recommend use of one of the synthetic lube oils given below.

For high-performance turbochargers (i.e. VTR..4P, VTR..4D, VTR..4E, a special low friction synthetic oil has to be used (see below).

The same applies to standard VTR..4 units if the turbocharger speed  $n_{B_{max}}$  exceeds the values specified in the table above and/or the compression ratio exceeds  $\pi_c > 3.5$ . Failure by the operator to comply with this recommendation could have negative consequences for the operation of the turbocharger.

### **Synthetic oils**

Max. interval between oil changes 5000 hours:  
Castrol "Aircol CT 68", Castrol "Aircol SN 68", Chevron "Synthetic Compressor Oil Tegra 68", Elf "Barelf CH 68", Exxon/Esso "Synesstic 68", Kuwait "Schurmann 68", Nycos "Nycolube 3060".

### **Special low friction synthetic oils**

Max. interval between oil changes 5000 hours:  
Agip "Dicrea SX 68", BP "Enersyn TC-S 68", Elf "Barelf SM 68", Mobil "Rarus SHC 1026", Shell "Corena AS 68" (ex "Madrela AS 68"), Texaco "Cetus PAO 68".

Max. interval between oil changes 3000 hours:  
Shell "Corena AP 68" (ex "Madrela AP 68").





### **Oil change intervals**

The intervals between oil changes for turbochargers are given in the engine-builder's manual. Other operating temperature levels may reduce the maximum interval between changes. Under no circumstances should the maximum intervals given above be exceeded.

### **Oil discoloration**

A synthetic oil may darken without losing its lubricating properties. The discoloration can range from red to dark purple to dark brown and nearly black. Quick darkening to black within a 12-hour period could be a sign of a mechanical defect. In such a case, the cause of the darkening should be investigated immediately.

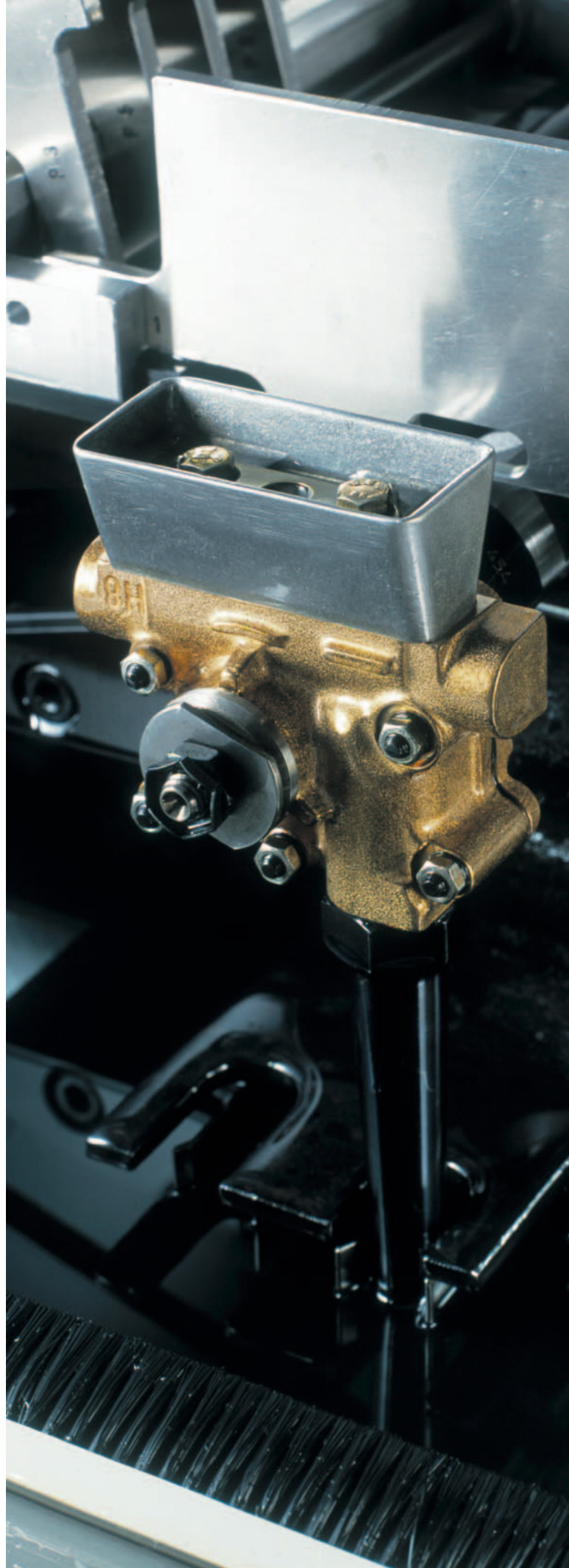

Field experience has shown that when disassembling and assembling the silencers (PN81100) fitted to the VTC..4, the cast-aluminum cone of the front funnel is susceptible to damage if incorrectly handled. This can lead to the cone breaking away during operation, causing turbocharger failure.



### Recommendation

Due to the confined working area and the lifting positions available on fast ferries, use of the silencer lifting brackets shown in the VTC..4 Operation Manual, chap. 5, sect. 3.1, is not always possible.

Extreme caution should therefore be taken when disassembling and assembling the silencer to ensure that the silencer does not strike the cone area of the aluminum front funnel. When removed from the turbocharger, the filter silencer must not be allowed to rest on the cone of the silencer. It should also be suitably protected when stored or in transit. If it is thought that the cone area may have been struck or damaged, it is recommended that a dye penetrate crack inspection be carried out before it is returned to service. When replacing the silencer, care must be taken to avoid contact with the compressor. In the event of the compressor being struck, the silencer should be removed and inspected for cracks. If there are signs of cracks the front funnel has to be replaced.

## Broken protection sleeves can damage blades

Turbo Magazine 1/00  
Article by Heinz Waelti

Signs of the following damage on a turbo-charger could indicate a problem with the protection sleeves in the compensators. If they start to break away, they could damage the blades as shown. To avoid further damage, please check all of the compensators (it will be necessary to balance the rotor). Please contact your nearest Service Center.



## Cleaning TPS filter-silencer parts

Turbo Magazine 2/00  
Article by Edi Wettstein

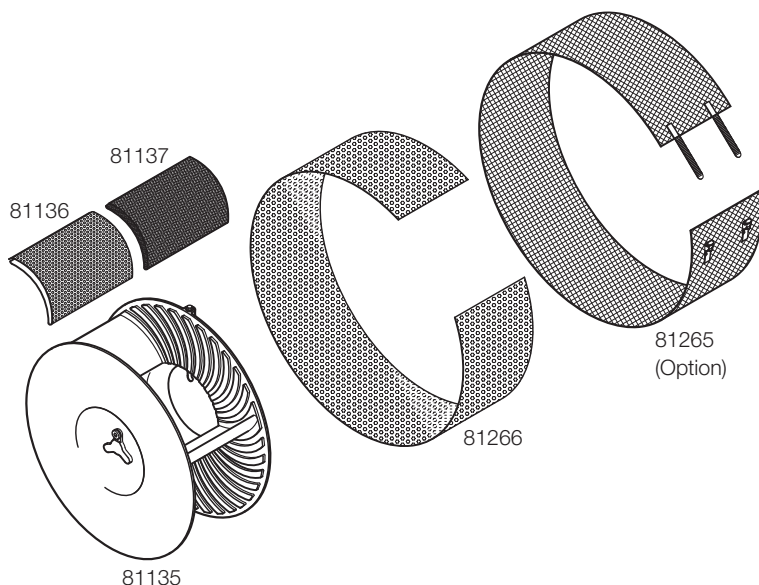

The filtration mats and silencer parts become dirty after a time (this depends, of course, on the quality and quantity of the air passing through the filter silencer system). If the contamination of the mats and silencer parts exceeds a certain limit, the turbocharger can enter a so-called surging state, which is characterized by instability of the airflow and is noticeable as an unpleasant “howling” or “barking” noise.

To prevent such a disturbing and obviously unwanted running condition, filtration mats 81265 can be removed and washed before being re-used. The washing procedure can be repeated as often as 5 times, after which the mats should be replaced by new ones. To ensure safe operation, always install a clean filtration mat while washing and drying the soiled one. Filtration mats can be ordered in double packs from any ABB service station.

However, do not wash the silencer segment parts 81136/37, which should be cleaned only by brushing or using compressed air. To replace heavily soiled and worn segments, contact any of our service stations.





### **Washing procedure**

- Remove filtration mats 81265 from filter/silencer body.
- Prepare a bucket with water at approx. 40 °C and add some washing powder.
- Launder the mats by soaking them for approximately 15 minutes, rinse them with fresh, clean water, and finally squeeze them out carefully.
- Do not subject them to any high mechanical stress by wringing them out strongly or by cleaning them with a powerful water jet.
- Dry the mats thoroughly before fitting them back on the silencer body.

Although ABB turbochargers are built to the highest standards and every care is taken to ensure their safe and reliable operation, they are not always immune to failure. This can be especially annoying if the engine cannot be taken out of service or the time for repair is too short because the engine power is still needed.

Did you know that the turbocharger could be blanked off without affecting the power more than is absolutely necessary? For example, with our new TPL turbocharger, the cartridge group (rotor block, Fig. 1) can be removed and the open gas outlet casing closed with a blanking cover (Fig. 2). This will allow the engine to at least be used – with a lower power – until the next repair opportunity arises.

In an emergency you could make the blanking cover yourself, following the instructions in the ABB Turbocharger Operation Manual (see section on “Taking turbochargers out of operation”).

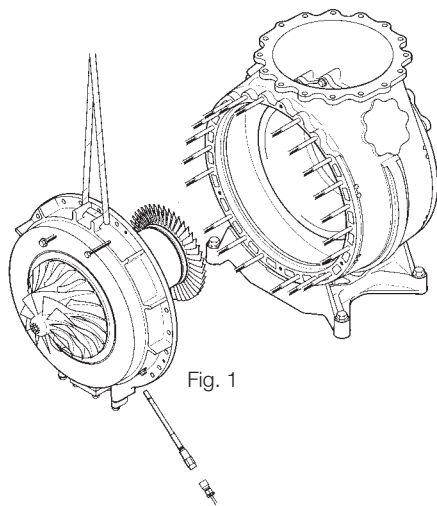

Fig. 1

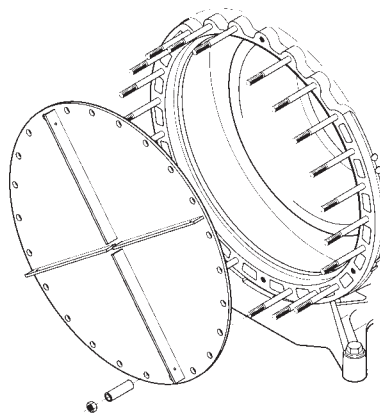

Fig. 2

### Recommendation

We recommend that you familiarize yourself with the instructions for emergency operation as given in the Turbocharger Operation Manual or in the engine manual before beginning. You could also prepare the blanking device in advance and run through the procedure for fitting it in an emergency.

For further information, please contact your nearest ABB service station.

### Caution!

- The turbocharger oil supply pipes of the blanked turbocharger have to be closed!
- In cases where several turbochargers on one engine discharge into a common air receiver, the air-outlet of the damaged turbocharger must be blanked off!
- The maximum speed of the turbocharger(s) remaining in operation must be observed at all times!

For details, please consult the ABB Turbocharger Operation Manual.

## Turbine washing – the right way

Turbo Magazine 1/04  
Article by Sebastian Herrmann

Field experience has shown that how and when a turbocharger's turbine is cleaned can greatly affect the engine output. The right cleaning method and right cleaning intervals are therefore important for optimization of engine performance.

The trend towards higher engine outputs has led to a parallel increase in the exhaust-gas temperature, and thus to higher gas inlet temperatures before the turbocharger turbines. Because of this operators need to be more careful when cleaning their turbochargers. It is especially important to wait long enough for the turbine to cool down to the right temperature and, after washing, to wait for it to dry again before the turbocharger is returned to normal load operation. Special attention should also be given to the intervals between cleaning.

**Caution:** Washing a turbine which is still at a high gas-inlet temperature and/or too frequent washing can cause cracks and deformation of the turbine-end components, thereby drastically shortening their useful life.

### Washing the turbine of VTR and TPL turbochargers

- Before washing the turbine, make sure that the exhaust-gas temperature is not higher than 430 °C (in the case of thermal shock cleaning of the TPL, not higher than 500 °C).

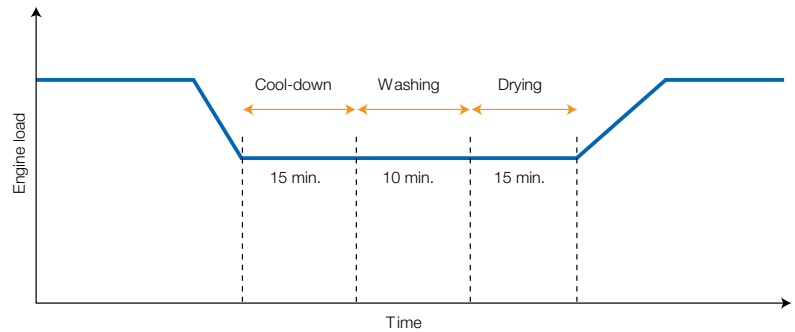

- ABB recommends waiting for a certain length of time (see diagram) before and after washing. Wait at least 10 minutes (preferably 15 minutes) after reducing the temperature before injecting water, and again after washing to give the material time to adapt to the exhaust-gas temperature. Following this procedure will significantly reduce stressing of the turbine and other components exposed to the exhaust gas, as well as reduce the formation of thermal cracks.
- If HFO-quality fuel is being used, we advise you to plan your cleaning intervals according to your actual needs. The less often a turbine is cleaned the less it will be stressed by thermal cycles, but the more contaminated it will be. We recommend an iterative approach to this problem using the exhaust-gas temperature and pressure as indicators and based on your own experience of the installation.

Feel free to consult your local ABB service partner if you require assistance.

## Early warning of inducer wheel failure

Turbo Magazine 1/05  
Article by Norbert Mlekusch



Inducer wheels are not subjected to the kind of loads that some other turbocharger components<sup>1</sup> have to withstand, which is why the rating plate on VTR/VTC turbochargers gives no replacement intervals for them. However, the main and splitter blades of the inducer wheels are susceptible to damage in the form of high cycle fatigue (HCF).

Metallurgical investigations have shown that an initial cause of blade fracture can be pitting corrosion, leading to “notch effect”. Pitting originates when the turbocharger is at standstill and is caused by water-soluble residues such as sulphur (in the exhaust gas) and/or salt (in the intake air).

---

<sup>1</sup>ABB has introduced the so-called SIKO program for evaluating the lifetime of the most heavily loaded rotor components – the impeller wheel and turbine shaft.

### Recommendation

Critical corrosive attack can be detected by means of non-destructive checks. ABB therefore recommends periodic fluorescent penetrant inspections on the inducer blade surfaces (if this is not possible, the blades can be dye-checked). The results of these inspections might indicate that it is necessary to replace the inducer wheel immediately or during the next overhaul as a precaution against sudden failure.

If you should require any assistance, please do not hesitate to contact your local ABB service partner.



Damaged inducer wheel.



Close-up of a broken splitter blade.

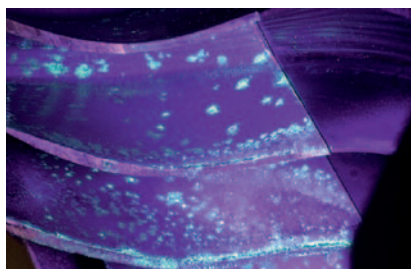

Pitting corrosion revealed on inducer wheel blades by fluorescent penetrant inspection.

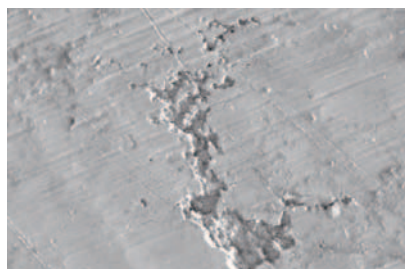

Pitting corrosion (detail).



# Engine performance deterioration after turbocharger overhauls?

Turbo Magazine 2/05

Article by Thomas Knuesel

Occasionally, reports are received from the field noting a minor deterioration in engine performance following a turbocharger overhaul. What operators generally notice is a slight increase in exhaust gas temperature right after the engine cylinders or in the mean temperature level just before the turbocharger(s). In some cases, the temperature increase has even activated the engine control system's high-temperature alarm. As this can give the impression that the turbocharger overhaul hasn't been done properly, it is important for operators to understand the phenomenon.

Modern engines are designed with high power densities and have a tendency to be sensitive to even minor changes in the combustion process. The highest possible turbocharger efficiency and performance would be achieved in the ideal case of zero clearance between the turbine blade tips and turbine diffuser (cover ring). Obviously, this is not possible in practice, as there has to be a certain clearance for free shaft rotation and movement.

## Build-up of contamination

In normal engine operation, and especially when heavy fuel oil is burnt, the turbocharger's turbine blades, diffuser and other exhaust gas components are subjected to wear and tear as a result of erosion and/or corrosion caused by the gases and the particles they carry. Also, during operation, a layer of scale is deposited on the turbine diffuser, thereby reducing the gap (i. e. clearance) between the turbine blade tips and diffuser.



Layer of scale deposited on a turbine diffuser

Chemical analysis of the contamination from some installations burning heavy fuel oil has shown that it is composed of sodium-vanadyl-vanadate compounds. These chemicals promote high-temperature corrosion on metal surfaces exposed to temperatures in the range of 530 °C to 630 °C. The contaminants can also be very hard, so that contact with the turbine blades causes the blade tips to wear.

## Engine performance deterioration after turbocharger overhauls? (cont.)

The layer of scale is usually removed during a turbocharger overhaul. However, in cases where there has been tip erosion the tip clearance may afterwards exceed the tolerance limits, causing a slight drop in the turbine's rotational speed and a loss of efficiency. After the turbocharger is returned to operation, new scale rapidly builds up on the diffuser and quickly compensates for the additional clearance. Optimal performance is usually regained within a few days.

### What operators can do

In cases where high-temperature alarms are triggered after a turbocharger overhaul, ABB recommends either replacing the components or reconditioning the turbine blades. A feasible, and more economical, alternative would be to refrain from cleaning the entire surface of the turbine diffuser. Simply clean the high spots (e.g. by wiping them with sandpaper) so that a base layer of contamination remains. If this method is preferred, we recommend that you always keep the rotor and the turbine diffuser together as a pair.

Providing the turbine is cleaned regularly during operation, the formation and flaking off of deposits should balance out in time, with no further increase in deposits and reduction/stabilization of blade tip wear.

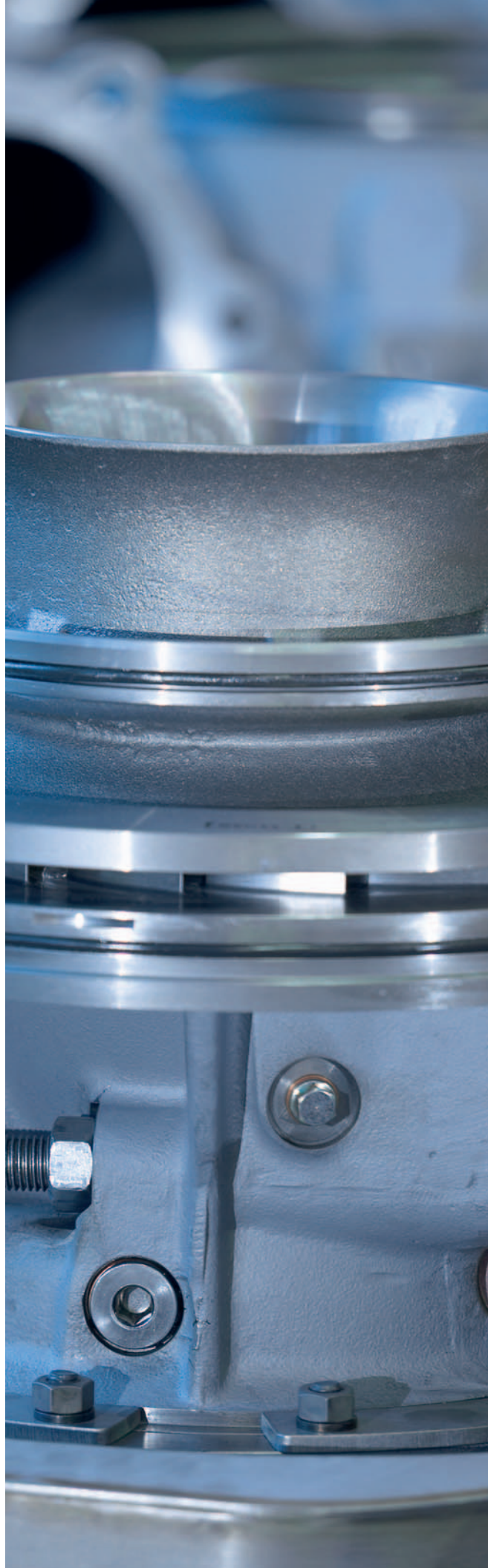

## V-clamp connections on TPS turbochargers

Turbo Magazine 3/05  
Article by Thomas Knuesel

TPS 57, TPS 52 and TPS 48 turbochargers delivered since October 2000, September 2003 and October 2003, respectively, have bolted casing connections, i.e. bolts connect the turbine casing to the bearing casing and the bearing casing to the compressor casing. TPS 57, TPS 52 and TPS 48 turbochargers delivered before these dates have their casings connected by V-clamps.

On some TPS units where V-clamps are used, it has been noticed that these are not fastened properly. If the torque used to tighten the hexagon socket screw is not correct, the casings and internal components can move, causing gas to leak. On engines where this has happened, it was also often noticed that the structure supporting the exhaust-gas system after the turbocharger was not rigid enough.

Signs of insufficient clamping are minor gas leakage and/or slight signs of wear on the nozzle ring lugs with corresponding grooves on the turbine casing.

### Check regularly

ABB recommends that operators regularly check the tightening torque and fit of the V-clamps as well as the fit of the casing flanges on all TPS turbochargers with this type of connection at intervals of 500 to 1,000 running hours. The recommended tightening torque in every case is 60 Nm.

As a precaution, V-clamps on the turbine side should be replaced during every standard turbocharger overhaul. Immediate replacement is advised in the event of damage of the kind shown in the photos.

Detailed instructions for cartridge group replacements and for replacing V-clamps can be found in chapter 5 of the TPS Turbocharger Operation Manual.

If you require further help, please contact one of our service stations.



Severe wear at screw-head.



Deformed or wrong washer.



Cover tape detached.



Cover tape severely deformed.



## Don't worry about dry cleaning!

Turbo Magazine 1/06  
Article by Norbert Mlekusch



Worn turbine diffuser.

Periodical dry cleaning is the most effective and economical method of cleaning turbo-charger turbines on two-stroke engines. Providing the recommended materials (e.g. nutshells), and also original spare parts, are always used, ABB is confident that no erosion of the turbine parts will occur as a result of this method of cleaning.

ABB bases this assurance on extensive field experience and on the fact that since dry cleaning lasts no more than 20 seconds, even if it is performed 250 times a year the turbine parts will be subjected to impact by the cleaning material for less than 2 hours. This is negligible compared with the yearly running time of about 6,000 hours.



Worn turbine blade tips and turbine diffuser.

Erosion due to particles in the exhaust gas usually occurs on small segments of the turbine diffuser and outer hoop of the nozzle ring, equal to about 15 to 25% of the total circumference. The wear starts more or less opposite the single radial gas inlet and then continues clockwise around the turbine (viewed from the turbine side). The tips of the turbine blades can also be affected, with all of them showing equal signs of wear.





## **Cleaning a turbocharger's turbine – when and why**

**Turbo Magazine 2/06**  
**Article by Sebastian Herrmann**

Cleaning – what's the point? Don't things just get dirty again? No-one who's seen a turbocharger turbine after just a few hundred hours of operation, especially when the engine burns HFO or some other low-grade fuel, would ever doubt it. That's why ABB recommends regular cleaning of the turbocharger during normal operation.

### **Why does the turbine get so dirty?**

The gas given off by heavy fuel oil during combustion contains particles that attach themselves to every part of the exhaust gas system. In the turbocharger these particles stick to the turbine blades and nozzle ring, forming a layer of dirt which reduces the turbine area and causes a drop in efficiency. To limit this effect, the turbine has to be cleaned during operation, at intervals of 48 to 500 hours.

### **How often is too often?**

Getting the cleaning intervals right for 4-stroke applications isn't always easy. If washing is carried out too often the cleaning results will be good, but the thermal cycles increase. This causes material stress and may impact component durability, especially if the washing temperature is too high (thermal stress can cause cracking; the more thermal cycles, the faster the cracks develop and propagate.)

### **What happens if I wait?**

If, instead, the intervals between washing are too long more dirt will build up, causing a drop in turbocharger efficiency, blockage and an increase in the exhaust gas temperature.

## Cleaning a turbocharger's turbine – when and why (cont.)



Components still very clean: cleaning intervals could be longer.



Components are sufficiently clean: no changes needed.



Components too dirty: shorten cleaning intervals.

The layer of dirt can also harden. If this happens it can only be removed by – usually unscheduled – mechanical cleaning of the turbine-side parts!

### Getting the balance right

In both cases there is a financial impact: Too-frequent washing results in a loss of availability (due to the necessary load reductions) while worn out parts have to be replaced more often; too-long intervals between washing also lead to a loss of availability (due to the unscheduled downtime for mechanical cleaning), and then there's the cost of the work itself.

Each of these situations can be avoided by working with the engine builder and ABB to set up an application-specific washing schedule. This involves first watching some key operating parameters – turbocharger speed (rpm), exhaust gas temperature directly before the turbine (°C) and air outlet pressure (bar) after the compressor – and observing the trend. For a given engine reference load, the values should remain within certain limits (normally provided by the engine builder). If they stray outside these limits, wet cleaning should be carried out. During the first 2 or 3 service jobs, photos can be taken of the turbine and nozzle ring to compare their state, noting each time the fuel used and the actual cleaning interval. With this documented information available, the operator is in a better position to judge whether the cleaning interval should be longer or shorter.





## Is your engine room turbocharger service friendly?

Turbo Magazine 1/07  
Article by Köbi Brem

Life in a ship's engine room follows more or less a fixed pattern: machines and their component parts – cylinder heads, fuel injectors, and especially the all-important turbochargers – have to be regularly checked, maintained and cleaned.

In order to work quickly and efficiently, turbocharger service engineers must be able to move freely around the machines on a conveniently placed platform and have cranes at their disposal for the disassembly and reassembly. These should be positioned precisely above the centre-line of the turbochargers. Deck openings and onboard cranes should also be provided at convenient locations in case turbocharger parts have to be moved to and from the engine room.

### “Nice to have”

In its manuals for engine- and ship-builders, ABB therefore includes recommendations on how to arrange the space around the turbochargers. The manuals give the size of the area that needs to be kept free for disassembly and the movement of parts and also suggests locations for the railings, where cranes should be positioned, or where chain blocks are needed above the turbochargers.

By following these guidelines, shipowners ensure a service-friendly environment with a genuine payback in terms of time, and thus costs, saved. And it reduces the risk of damage to key turbocharger parts, the repair or replacement of which could upset a ship's sailing schedule. Last but not least, shipowners who

take the guidelines to heart underline their concern for safety. Accidents are less likely when the large, heavy turbocharger parts can be properly lifted and manoeuvred around the ship.

### The real world

The real world, however, can look very different; railings end above the last cylinder head, or there are not enough lifting points for chain blocks, making it impossible to work effectively.

A poorly designed working environment – badly positioned or too few lifting lugs, railings that get in the way, platforms at the wrong height – not only increases the risk of damage to the parts being handled. Moving heavy turbocharger parts under such conditions is also a safety hazard.

### What operators can do

Operators who work regularly with service engineers see the problems and understand the extra costs they can incur over a ship's lifetime. On ships lacking the necessary amenities for efficient servicing, it is both in the operator's interest and in the shipowner's financial interests to bring the engine room infrastructure up to standard. By reporting to the ship's superintendent what's missing or needs changing, the operator can help to ensure his vessel's reliable and economic operation while at the same time contributing to better on-board safety conditions. Passed on up the chain of communication, the information can also be useful during the design of future ships.

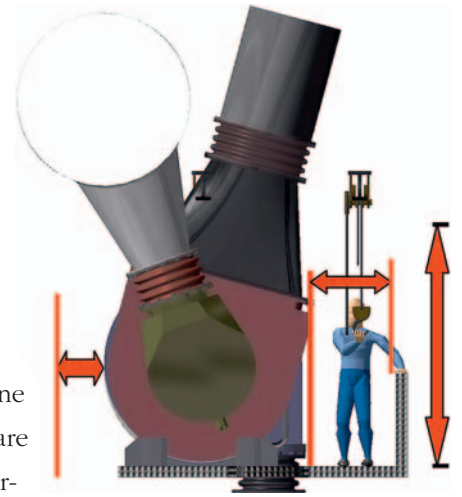



Status: February 2008

Aberdeen · Agadir · Algeciras · Antwerp · Auckland · Baden · Baku · Bangkok · Bergen · Bremerhaven · Brisbane · Buenos Aires · Busan · Cairo  
Cape Town · Casablanca · Cebu · Chennai · Chicago · Chittagong · Chongqing · Colombo · Copenhagen · Dakar · Dalian · Darwin · Delhi · Dortmund  
Dubai · Dunkerque · Durban · Faroe Islands · Fukuoka · Gdansk · Genova · Gothenburg · Guangzhou · Guatemala City · Hamburg · Hanoi  
Helsinki · Hong Kong · Houston · Incheon · Istanbul · Izmir · Jakarta · Jeddah · Kaohsiung · Kobe · Lahore · Las Palmas · Le Havre · Lima  
Los Angeles · Lunenburg · Madrid · Malta · Manaus · Manila · Mannheim · Marseille · Melbourne · Miami · Montreal · Mumbai · New Orleans  
New York · Oporto · Oslo · Panama · Perth · Piraeus · Quito · Reykjavik · Rijeka · Rio de Janeiro · Rotterdam · Saint Nazaire · Santo Domingo · Santos  
Seattle · Shanghai · Singapore · Southampton · St. Petersburg · Sunderland · Surabaya · Sydney · Talcahuano · Tallinn · Telford · Tianjin · Tokyo  
Vadodara · Vancouver · Varna · Venice · Veracruz · Vladivostok



## ABB Turbo Systems Ltd

Bruggerstrasse 71a  
CH-5401 Baden/Switzerland  
Phone: +41 58 585 77 77  
Fax: +41 58 585 51 44  
[www.abb.com/turbocharging](http://www.abb.com/turbocharging)  
e-mail: [turbocharging@ch.abb.com](mailto:turbocharging@ch.abb.com)