

# Rolls-Royce propellers

Kamewa CP-A controllable pitch propeller



## OD box in front end of gearbox – system D-F

Illustration showing type F system with oil distribution box mounted on the forward end of the reduction gearbox. The OD box incorporates the pitch feed back system.

## OD box in shaft line – system D-M

Illustration showing type M systems with oil distribution box in the shaft line.

The Kamewa type A system is a development of a successful and well-proven design. The improvements it incorporates will ensure that it continues as market leader. Detailed requirements from different parts of the marine market have been taken into account so that the new type A hub is suitable for a wide range of applications.

Design tools such as finite elements for detailed analysis of all components have resulted in a number of design improvements that significantly improve the strength of the hub and its moving parts to provide a longer service life.

The new hub shape developed with modern CFD tools also reduces drag, which gives benefits in propulsive performance.

Based on this new developed hub, Kamewa type A will cover a range of applications and will be offered in two options depending on the ship speed. The standard type A hub is ideal for speed up to 30 knots and for higher speed an H hub will be available.

The Kamewa type A is available in NiAl bronze or stainless steel and is optimised for all types of installation, from no ice to highest ice class, throughout the speed range.

Underwater replacement of blades as well as a feathering design are optional features.

The type A propeller is delivered with a hydraulic system, of up to date design with load sensing displacement pumps that limit noise and vibration, and reduce energy consumption.

The components are also easy accessible for maintenance and service.

The Kamewa type A-D system fulfils Naval standards, including shock requirements.

### The new type A is suitable for all kind of vessels such as

- cargo vessels
- container vessels
- cruise ships
- fast ferries
- naval vessels
- offshore vessels
- tankers
- yachts

# Fact Sheet

## Main dimensions

### 4-bladed propellers

NAV/ HUB	A	B	C	D	E	F	Gmin	G	H	** ) Weight	*** ) Weight
46	585	190	48	460	280	415	140	270	65	280	270
50	640	210	53	500	300	463	150	280	65	370	350
55	700	220	58	550	330	500	170	290	65	490	470
60	765	240	63	600	365	547	185	300	65	635	610
66	840	275	70	660	400	612	205	325	80	850	810
72	917	300	76	720	435	650	215	350	80	1110	1050
79	1005	320	83	790	480	700	235	375	80	1455	1390
86	1095	345	90	860	520	772	255	400	95	1875	1790
94	1170	375	97	940	600	840	280	425	95	2450	2340
102	1265	405	107	1020	650	920	305	650	110	3040	2985
111	1380	440	117	1110	705	1000	330	675	110	3920	3850
121	1502	482	127	1210	770	1090	355	750	125	5075	4984
132	1640	525	138	1320	840	1180	395	775	125	6590	6470
144	1780	575	150	1440	915	1285	420	850	150	8555	8400
150	1880	595	160	1500	960	1340	440	835	150	9670	9495
157	1969	625	165	1570	1007	1400	460	875	150	11090	10890
164	2055	655	172	1640	1050	1450	480	900	150	12580	12410
171	2145	685	180	1710	1095	1500	500	925	175	14260	14070
179	2245	715	188	1790	1150	1570	520	950	175	16360	16135
186	2330	730	195	1860	1195	1640	540	975	175	18350	18105
194	2435	772	204	1940	1245	1710	570	1050	175	20820	20540
202	2535	805	212	2020	1295	1820	585	1075	175	23510	23190
211	2645	840	222	2110	1355	1900	610	1125	200	26790	26430
220	2760	875	230	2200	1410	1980	640	1150	200	30370	29955

Weight = Hub without blade flange  
 Dimensions in the table are not binding. Right of alterations reserved.

### 5-bladed propellers

NAV/ HUB	A	B	C	D	E	F	Gmin	G	H	Weight
60	707	215	63	600	365	560	165	280	65	555
66	776	235	70	660	400	620	185	305	80	745
72	845	255	76	720	435	670	195	330	80	970
79	924	277	83	790	480	720	215	355	80	1275
86	1007	302	90	860	520	787	225	370	95	1645
94	1095	325	97	940	600	860	250	395	95	2105
102	1191	355	107	1020	650	935	275	620	110	2745
111	1295	385	117	1110	705	1020	295	640	110	3545
121	1417	425	127	1210	770	1090	320	715	125	4500
132	1542	460	138	1320	840	1210	350	730	125	5840
144	1755	575	150	1440	915	1285	420	850	150	7735
150	1824	595	160	1500	960	1340	440	835	150	8750
157	1912	625	165	1570	1007	1400	460	875	150	9715
164	1999	655	172	1640	1050	1450	480	900	150	11060
171	2086	685	180	1710	1095	1500	500	925	175	12540
179	2182	715	188	1790	1150	1570	520	950	175	14380
186	2254	730	195	1860	1195	1640	540	975	175	16130
194	2362	772	204	1940	1245	1710	570	1050	175	18300
202	2460	805	212	2020	1295	1820	585	1075	175	20670
211	2569	840	222	2110	1355	1900	610	1125	200	23550
220	2678	875	230	2200	1410	1980	640	1150	200	26720

Weight = Hub without blade flange  
 Dimensions in the table are not binding. Right of alterations reserved.

Hub designations

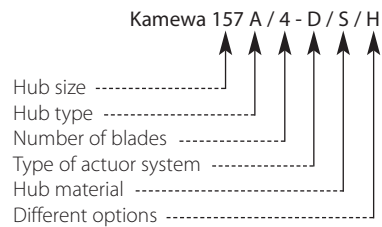

### Twin tube system

Gmin and G = Dismounting space (see drwg. 154069)

\*) Incl. flange cover

\*\* ) Standard and ice hub

\*\*\* ) Nozzle hub

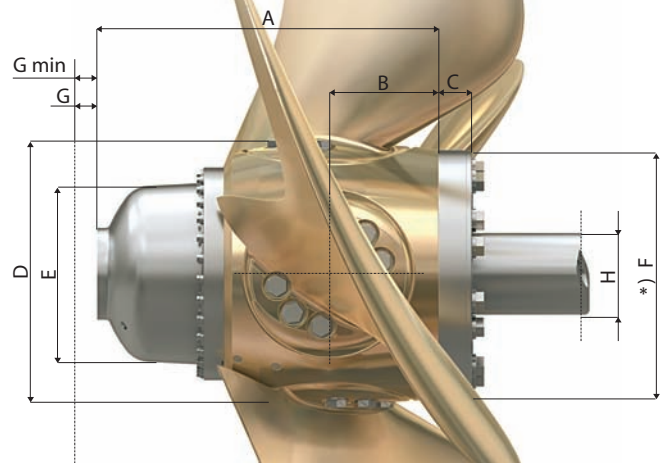

# Fact Sheet

## There are two OD box installation alternatives for Kamewa CPP systems

- type F0 and type M0

### Installation system F

The oil distribution box is mounted on the forward end of the reduction gearbox. Additional intermediate shafts can be arranged between the propeller shaft and the gearbox. The OD box also incorporates the pitch feed back system.

Type F0 requires the minimum overall installation space and is therefore the most favourable solution.

It is possible to remove the reduction gearbox without docking the ship.

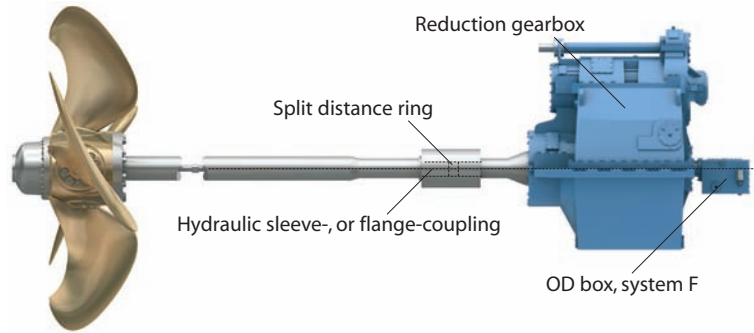
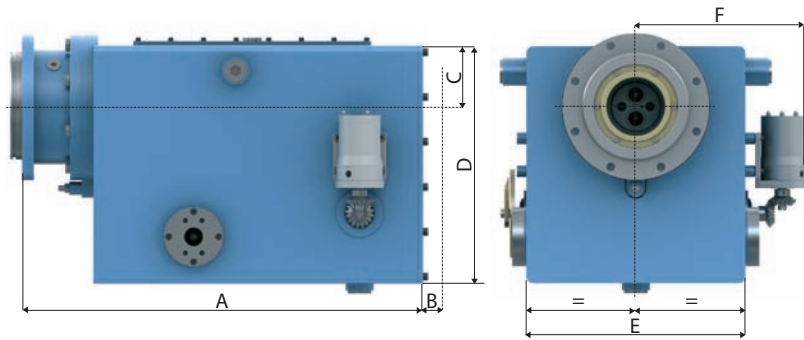

Table / pictures (Dimensions in mm)  
B=Minimum distance for OD box dismantling

T.O-BOX/ O.D.-BOX	A	B	C	D	E	F	Weight
35	355	121	78	240	210	233	50
50	481	116	77	294	274	263	90
70	651	170	105	400	380	314	205
100	860	221	130	510	470	364	330
140	1079	270	175	625	620	439	640



### Installation system M

A separate shaft carries the oil distribution box and additional intermediate shafts can be arranged between the propeller shaft and the OD box shaft. The forward part of the OD box shaft incorporates the pitch feed back mechanism and has an integral flange connecting to the engine output flange, reduction gearbox, or to solid intermediate shafts.

Table / pictures (Dimensions in mm)

\* Coupling placed on propeller shaft at installation

\*\* Coupling placed on OD box shaft at installation

Size	D Max	D1	D2	L min*	L min**
230	230	395	450	1350	1900
300	300	185	550	1620	2200
380	380	595	685	1910	2700
450	450	695	795	2140	3000
550	550	830	950	2400	3500
620	620	930	1100	3000	4200
700	700	1080	1240	3200	4700
900	900	1370	1560	4000	5800

(Dimensions in mm)

\* Coupling placed on propeller shaft at installation

\*\* Coupling placed on OD box shaft at installation

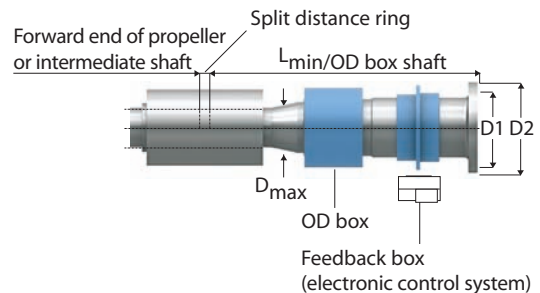
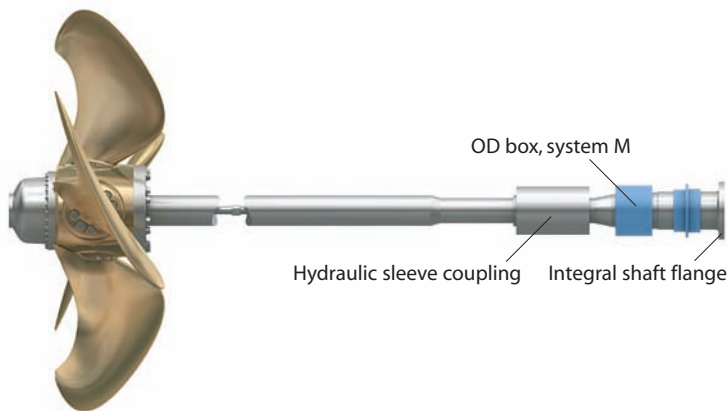

# Fact Sheet

## The hydraulic system

The power pack unit is state of the art design equipped with two redundant electric motor driven pumps, oil tank, main pitch control valves and all other necessary valves, filter, and cooler. Sensors are integral parts of the unit.

### Main pumps

If the electric pumps are used as main pumps, one of the pumps is used as main pump unit while the other is set to stand-by. The electrical main pump supplies oil pressure for the pitch control and the stand-by pump will automatically start if the oil pressure drops below a pre-set level.

The two electrically driven pumps are used as main pumps or stand-by depending if the hydraulic system is equipped with a PTO driven pump or not.

The electrical pumps are of load sensing variable displacement type. Their special features are to give flow and oil pressure to the hydraulic system only when needed, and when not needed they are in idle mode. This feature minimises not only noise and vibration but it also provides pump power savings.

A continuously running double pump unit maintains the static oil pressure. This pump unit creates the pressure both for the lubrication and static pressure system in the hub as well as running the oil cooler and filtration system.

### Twin-tube system

Oil is transferred between the oil distribution box and propeller hub via a twin-tube system. Oil for hub lubrication is transmitted via the shaft bore outside the twin-tube.

HPP size	A	B	C	D	E	F	G	Min service space	Weight without oil	Weight with oil
150 lit	1060 mm	720 mm	1360 mm	980 mm	825 mm	650 mm	ø22 mm	1500 mm	1000 kg	1110 kg
300 lit	1120 mm	930 mm	1510 mm	1060 mm	1130 mm	830 mm	ø22 mm	1750 mm	1200 kg	1420 kg
500 lit	1360 mm	1090 mm	1620 mm	1240 mm	1220 mm	990 mm	ø22 mm	1800 mm	1350 kg	1700 kg
700 lit	1360 mm	1090 mm	1780 mm	1240 mm	1420 mm	990 mm	ø22 mm	1950 mm	1450 kg	1950 kg
1000 lit	- mm	- mm	- mm	- mm	- mm	- mm	ø- mm	- mm	- kg	- kg

Dimensions in the table are not binding.  
Right of alterations reserved.

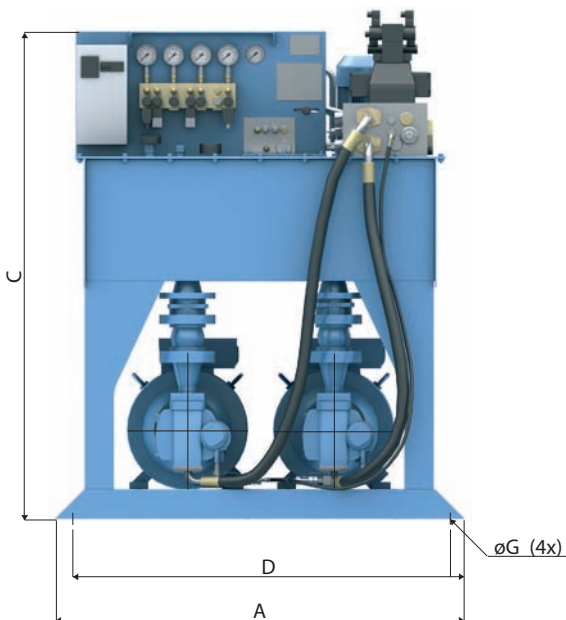

Hydraulic power pack, with instrument and valves

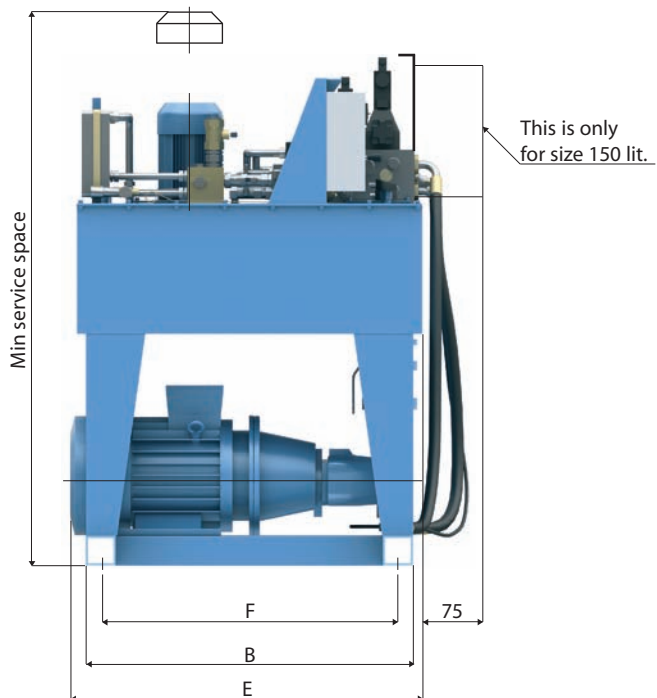

Pitch setting pumps, of variable load sense type



**Rolls-Royce**

Rolls-Royce AB  
P.O. Box 1010  
SE-681 29 Kristinehamn, Sweden  
Tel: +46 550 840 00 Fax: +46 550 181 90  
www.rolls-royce.com

© 2007 Rolls-Royce plc  
Whilst this information is given in good faith, no warranty or representation is given concerning such information, which must not be taken as establishing any contractual or other commitment binding upon Rolls-Royce plc or any of its subsidiary or associated companies.