

- ✓ High output;
- ✓ Compact dimensions;
- ✓ Low weight;
- ✓ High torque;
- ✓ Low noise and vibrations;
- ✓ Low emission;
- ✓ Low lube oil consumption;
- ✓ Low maintenance;
- ✓ Rapid on-site engine module change-out;
- ✓ Rapid engine exchange.



6.2 Advantages of Marine Aero-derivative Gas Turbines:-

6.2.1 Operation:

- Gas turbines do not emit black smoke during transient loads;
- Gas turbines pick up load very rapidly, at a rate of about 1 MW per second;
- Turbines are "hands-off" machines, if the control system does not indicate any problems, it does not need any maintenance activity. During start-up, operation and shut-down, the gas turbine is operated through the turbine control system, which controls fuel management, but also monitors turbine condition. If any parameter exceeds pre-set limits, the turbine control system will give an alarm and reduce turbine load to avoid damage. In case of serious problems, the control system will shut down the engine.

6.2.2 Maintenance:

- Gas turbine control system monitors engine performance and condition "on-line";
- "On-condition" maintenance avoids unnecessary scheduled maintenance, replace what needs to be replaced;

- Modular gas turbine construction allows for rapid exchange of engine modules, avoiding lengthy on-site repairs;
- Gas turbine size and weight allows for a complete engine change-out on-site within hours, without dry-docking or extended stays in port;
- Gas turbine and spares can be air freighted worldwide.

6.2.3 Reliability and availability:

- Aero-derivative gas turbines provide the very high reliability (> 99.5%) and availability (97.5%) associated with aero engines;

6.2.4 Environment:

- Low NOx and SOx emissions;
- Low particulates emission;
- No visible smoke during transient loads;
- No fuel sludge from heavy fuel oils.

6.2.5 Noise and vibration:

- Gas turbines are rotary machines, inherently low structure borne noise;
- Gas turbine packages feature an acoustic enclosure, reducing engine room noise levels and improving the quality of the working environment in the engine room;
- Resilient package mounting reduces structure borne noise even further;
- High pitched air borne noise is easily attenuated;
- Lower investment in air borne and structure borne noise insulation.

6.2.6 Vessel design:

- Low weight and compact dimension of gas turbine and ancillary systems allows design freedom in terms of location of engine room in the vessel;
- Smaller engine room leaves more space for revenue making purposes;
- Low weight allows the engine room to be moved away from the bottom of the vessel;
- Low noise and vibration levels improve crew and passenger comfort, allowing engine room spaces to be located closer to accommodation areas;

6.2.7 Propulsion plant design:

- Gas turbines have exhaust gas mass flow and temperature, which makes exhaust gas heat recovery both technically and economically feasible.

6.2.8 Installation:

- Gas turbine, control system and ancillaries are packaged on skids, ready for installation in the building blocks in the shipyard, speeding up the construction process;
- Gas turbine package with ancillaries are factory tested, reducing commissioning time in the shipyard;
- Gas turbine packages and ancillaries are assembled in the factory by specialized personnel, avoiding assembly problems and delays in the shipyard;
- Gas turbines are air cooled, eliminating the need for elaborate high and low temperature cooling water systems;
- Gas turbine lube oil is not exposed to the combustion process, resulting in very low lube oil consumption and eliminating the need for extensive lube oil conditioning systems;
- Gas turbines operate on MDO, obviating the need for fuel bunker heating, fuel line tracing and fuel conditioning systems

6.3 Disadvantages of Marine Aero-derivative Gas Turbines:-

6.3.1 Thermal efficiency:

- Gas turbine thermal efficiency is lower than the thermal efficiency of comparable diesel engines. Thermal efficiency of aero derivative gas turbines in the 20 - 30 MW class ranges from 36.5 to 40%. This makes the single cycle fuel consumption of a gas turbine about 20% higher than that of a comparable diesel engine;
- Gas turbine thermal efficiency is proportional to gas turbine output. Thermal efficiency of small gas turbines, in the 2 - 5 MW class, hardly exceeds 30%;

6.3.2 Liquid fuel quality restrictions:]

- Gas turbines can operate on either gaseous fuel or liquid fuel or both simultaneously, without any restriction in the ratio between fuels. However there are some severe restrictions on the quality of the liquid fuel. Vanadium and sulfur content should be kept within the specified limits in order to avoid high temperature corrosion of the turbine blades, which leads to loss of engine performance. In practice, the fuel specification completely rule out the use of any residual fuel and the cheaper distillates as well. ISO 8317-1996 Class F Marine Fuels MDO-DMA and DMX are suitable, but DMA might be a bit high on Sulfur.

6.3.3 Initial investments:

- Initial investment for a gas turbine engine in the 20 - 30 MW class is approximately 15 - 20% higher than in diesel engines of comparable output. For smaller gas turbines, especially derivatives of helicopter engines, the price difference is even higher;

All the above reasons might spell doom for many a marine gas turbine project. An rightly so, if the advantages do not offset the disadvantages of the use of gas turbines, the vessel will be an economic disaster. When the first series of gas turbines for cruise vessels were contracted in the late 1990s, some people temporarily lost their sense of perspective. All kinds of projects traditionally featuring diesels as prime movers, were suddenly re-engined with gas turbines of all makes and sizes. None of them made it through the project phase. Many of these projects failed because of the low thermal efficiency of smaller gas turbines. Even projects involving large gas turbines failed, mainly because of the high specific fuel consumption of the gas turbine and high fuel cost. With residual fuels usually being between USD. 60 and USD. 100 cheaper per ton than MDO and diesels being 20% more fuel efficient, single cycle gas turbines have a hard time competing.

6.4 Gas Turbine Myths and Misunderstandings

In the marine community there are still a lot of myths and misunderstandings about gas turbines.

Myth:

Gas turbines have very low torque and cannot be used in mechanical drive applications.

Fact:

Gas turbines can develop a very high torque, because the gas generator is aerodynamically coupled to the free power turbine. This allows the gas generator to spin up even when the free power turbine is stationary because moment of inertia of the propeller. When the gas generator develops sufficient air flow, the torque of the free power turbines overcomes the inertia of propeller.

Myth:

Gas turbines are unable to take instant load application.

Fact:

The design of the gas turbine, with the gas generator aero-dynamically coupled to the free power turbine, lends itself very well to instant application of heavy loads, which occur when a generator suddenly trips off-line. The speed of the

free power turbine might drop momentarily, but the gas generator will generate sufficient airflow to correct free power turbine speed almost instantly.

Myth:

Gas turbines only run on jet fuel.

Fact:

Gas turbines are perfectly happy to run on any liquid fuel available, as long as the combustion properties are all right. Technically it is possible to burn well separated residual fuels. However, commonly available residual fuels have high contents of Sulfur, Vanadium and alkali metals. The marine liquid fuel specifications of the gas turbine manufacturers have been compiled to ensure satisfactory hot section replacement intervals. Distillate fuels, such as MDO DMX and DMA (ISO-8217:1996(E), Category ISO-F) are acceptable, provided the Sulfur content is below 1.0%. Higher Sulfur and alkali metals content will reduce hot section lifetime accordingly. Vanadium content is given as 0.5 ppm maximum to reach a satisfactory lifetime. Higher Vanadium content will accelerate high temperature corrosion of the turbine blades. The replacement cost of a prematurely worn hot section will definitely offset the gains of using non-compliant fuels.

6.5 Marine Gas Turbine Applications

There are indeed some commercial marine applications in which gas turbines perform very well:

Fast ferries:

Low weight and small size of gas turbines, as well as simple arrangement of ancillary systems, leave more space for revenue making purposes; High gas turbine output makes it possible to satisfy high speed required. In some cases one fast ferry can replace two conventional ferries.



Cruise vessels:

- Combined cycle operation reduces specific fuel consumption to more competitive levels. Usually one gas turbine can service the power requirements of the entire vessel;
- Lower engine room space requirements allow for an increase in passenger capacity within the same dimensions;
- Low noise and vibration enhance passenger comfort;
- No visible smoke makes operations in Alaskan water possible;
- Low NO_x and SO_x emissions allow operations in environmentally sensitive areas.



CHAPTER 7

GAS TURBINE ELECTRIC DRIVE LNG CARRIER

The gas turbine electric drive power plant is the power plant that allows most flexibility in the design and layout of the vessel. The gas turbine drives the propeller shaft by way of an electric shaft. This arrangement allows the gas turbine generator power plant to be located away from the tank top. In this case, the power plant is housed in the superstructure, located over the mooring winch deck. The engineroom size can therefore be reduced substantially, increasing cargo capacity by approximately 19,000 cubic meter. The traditional LNG carrier hull can be maintained, to minimize redesign costs.

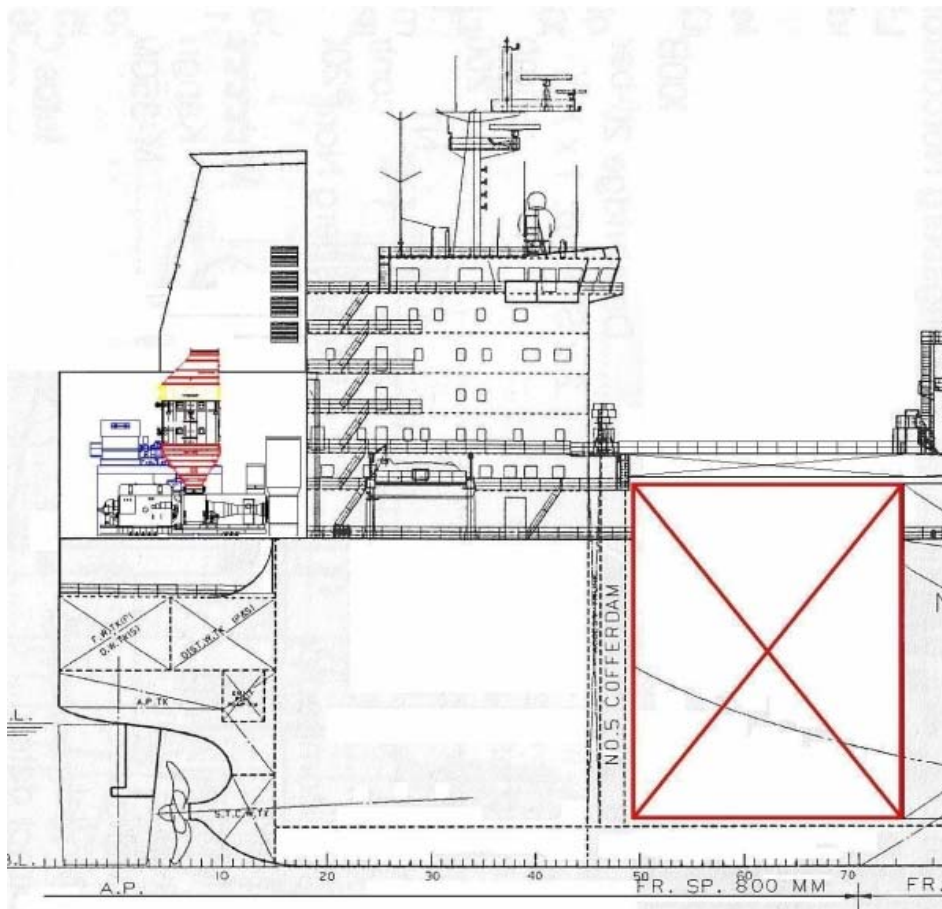
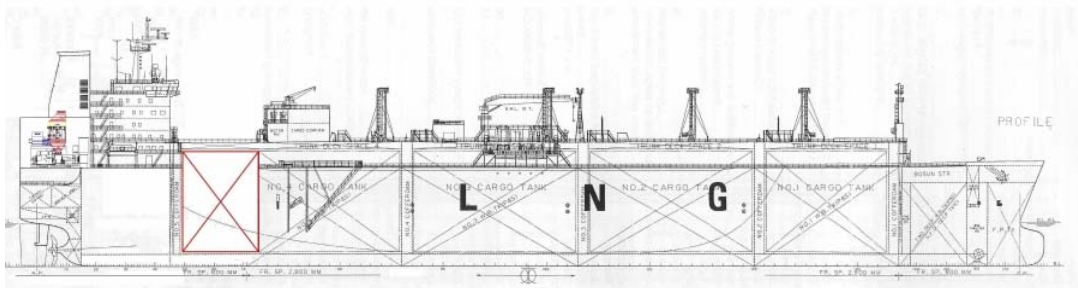

7.1 Gas turbine electric drive combine cycle propulsion

- 1 x Dual-fuel marine gas turbine generator, output 27 MWe;
- 1 x Steam turbine generator, output approximately 10 MWe;
- 1 x Exhaust gas boiler with supplementary firing and duct firing capabilities;
- 1 x Frequency controlled electric motor;
- 1 x FPP.

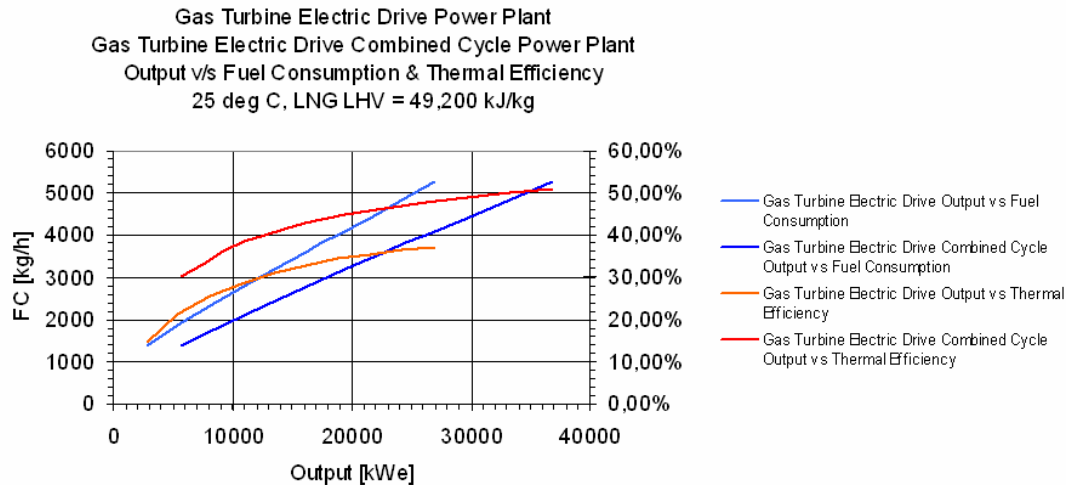

As can be seen in the fuel consumption and thermal efficiency diagram, the thermal efficiency of the gas turbine electric drive power plant exceeds 50 % in combined cycle operation. At operating conditions, the thermal efficiency is approximately 48 %.

The free power turbine of the gas turbine drives the generator. The generator feeds into the main switchboard. The main switchboard feeds all electric consumers. The propeller is driven by a frequency controlled electric motor. The exhaust gasses from the gas turbine raise steam in an exhaust gas boiler. This steam is used to produce power in a 10 MWe steam turbine generator. The steam turbine generator also feeds into the main switchboard.

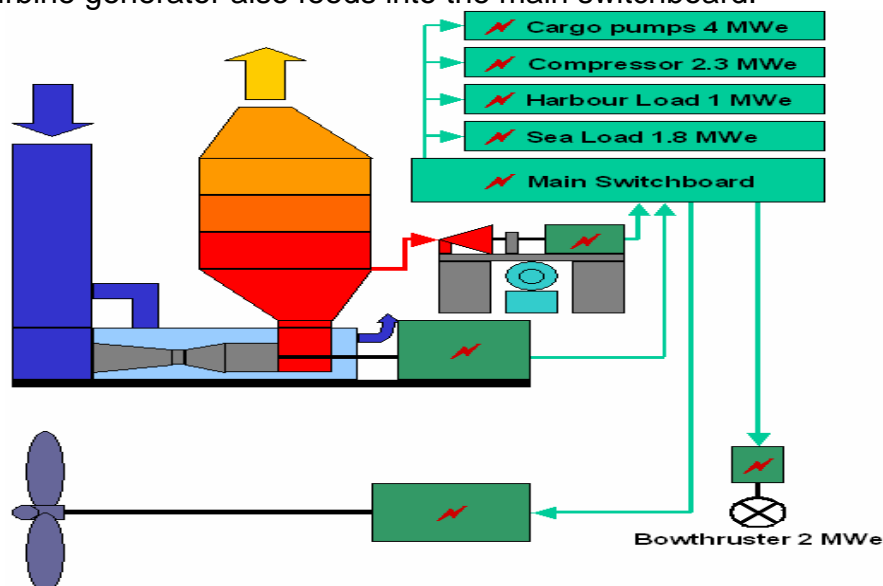

7.2 The advantages are:

- High thermal efficiency;
- Up to 13.8 % more cargo capacity;
- Propulsion and power generation redundancy;
- Dual-fuel capability;
- No hull redesign cost;
- FPP can be used without reversing gear;
- Low maintenance;
- Simplified engine room arrangement, smaller steam system, smaller cooling water system;
- Reduced installation and commissioning time in the shipyard through factory assembled and tested package.

7.3 The disadvantage are:

- Energy conversion losses in the electric drive system;
- Gas compressor required to supply gaseous fuel at 30 bar pressure to the gas turbine. Parasitic load can go up to 2.3 MWe;
- More complex and expensive than mechanical drive;

- The operational profile of the power plant can be divided in a few distinct service modes:

7.4 Normal cruising speed:

7.4.1 Loaded:

The gas turbine generator is the prime mover, using the available BOG as primary fuel. Gas turbine exhaust gas heat is recovered in the boiler to generate steam. The gas turbine generator and the steam turbine generator feed the electric consumers from the main switchboard. The electric motor mounted on the propeller shaft drives the propeller.

In ballast:

Heel scenario: The gas turbine generator is the prime mover, using the available BOG as primary fuel. To make up the balance of the fuel requirements, extra LNG has been left in the tanks to be regassified when required. Gas turbine exhaust gas heat is recovered in the boiler to generate steam. The gas turbine generator and the steam turbine generator feed the electric consumers from the main switchboard. The electric motor mounted on the propeller shaft drives the propeller;

Heel + liquid fuel scenario: The gas turbine generator is the prime mover, using the available BOG as primary fuel. To make up the balance of the fuel requirements, liquid fuel (MDO) will be supplemented. Gas turbine exhaust gas heat is recovered in the boiler to generate steam. The gas turbine generator and the

steam turbine generator feed the electric consumers from the main switchboard. The electric motor mounted on the propeller shaft drives the propeller;
Liquid fuel scenario: The gas turbine generator is the prime mover, using liquid fuel as primary fuel. Gas turbine exhaust gas heat is recovered in the boiler to generate steam. The gas turbine generator and the steam turbine generator feed the electric consumers from the main switchboard. The electric motor mounted on the propeller shaft drives the propeller.

7.4.2 Maneuvering:

The gas turbine generator is the prime mover, using the available BOG as primary fuel. The gas turbine generator and the steam turbine generator feeds into the main switchboard. The main switchboard supplies all electric consumers, including 4 MWe propulsion power to the propeller and 2 MWe bowthruster load; Should the gas turbine generator fail during maneuvering, can the steam turbine generator pick up the propulsion load. Steam for the steam turbine generator will be raised by firing the boiler on either BOG or liquid fuel or a mixture of both; Should the steam turbine generator fail during maneuvering, can the gas turbine generator supply the electric consumers through the main switchboard.

7.4.3 Harbour load:

The steam turbine generator is supplying the electric consumers through the main switchboard. Steam is being raised by firing the boiler on liquid fuel.

7.4.4 Cargo discharge:

The steam turbine generator is supplying the cargo pumps and the electric consumers through the main switchboard. Steam is being raised by firing the boiler on liquid fuel.

7.4.5 Emergency situations:

Should the gas turbine generator fail during the voyage, can the steam turbine generator provide approximately 8 MWe to the propeller shaft through the electric motor on the propeller shaft. Steam is being raised by firing the boiler on either BOG, BOG and liquid fuel or liquid fuel only, depending on availability. 8 MW propulsion power should keep the vessel maneuverable and she can proceed to the nearest port for repairs, should it prove impossible to remedy the problems at sea.

Should the steam turbine generator fail during the voyage, can the gas turbine generator supply the electric consumers through the main switchboard. With just over 4 MWe necessary for the electric consumers at sea, sufficient propulsion power remains to ensure good seakeeping and minimize delays in the schedule. If the problems can't be corrected at sea, spares and replacement equipment can be loaded at the next port of call.

7.5 Gas Turbine Electric Podded Drive LNG Carrier

The present LNG carrier is radically redesigned to exploit the full advantages of combined cycle gas turbine electric drive propulsion system. The engine room in the present design has been removed to make space for an extra cargo tank and MDO bunkers. The gas turbine generator, the steam turbine generator, the exhaust gas boiler, the condensers, the steam system and fuel handling systems have been moved to a dedicated superstructure on the main deck, over the mooring winch deck. Similar mooring deck arrangements can be found on cruise vessels and post-panamax container vessels.

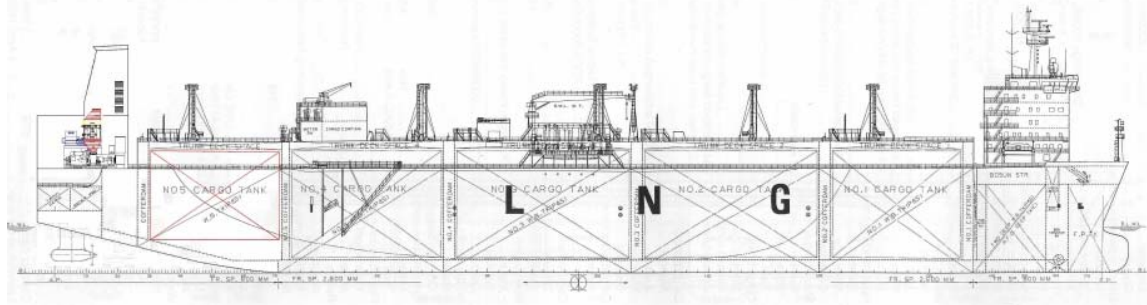

One or two podded drive propulsors are mounted beneath the hull to replace the FPP and the rudder. The podded drives place the main propulsion motors outside the vessel, saving space inside the vessel for revenue making purposes. Since there is no need to taper in the hull towards the stern boss, the parallel midship is extended to the transom. The keel gradually rises aft of frame 70 to provide a smooth flow of water to the podded drives. Without any taper, the hull frames are U-shaped and consequentially hull construction is much simpler and cheaper

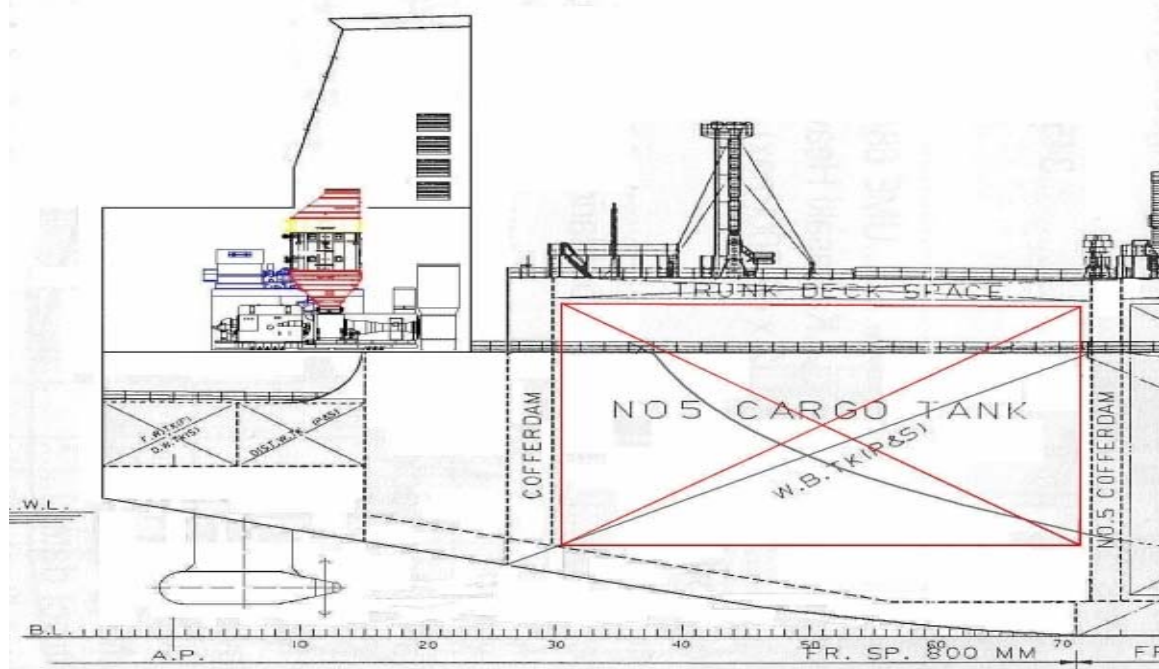

.An extra cargo tank between frame 71 and 30 could increase cargo capacity by up to 24,000 cubic meter. Aft of cargo tank 5 between the cofferdam and the aft peak bulkhead MDO bunker can be located, with a total capacity of up to 5,200 cubic meter.

7.6 Gas turbine electric drive combine cycle propulsion

- 1 x Dual-fuel marine gas turbine generator, output 27 MWe;
- 1 x Steam turbine generator, output approximately 10 MWe;
- 1 x Exhaust gas boiler with supplementary firing and duct firing capabilities;
- 1 x Frequency controlled electric motor;
- 1 (or 2) x Podded drive(s).

As can be seen in the fuel consumption and thermal efficiency diagram, the thermal efficiency of the gas turbine electric drive power plant exceeds 50 % in combined cycle operation. At operating conditions, the thermal efficiency is approximately 48 %.

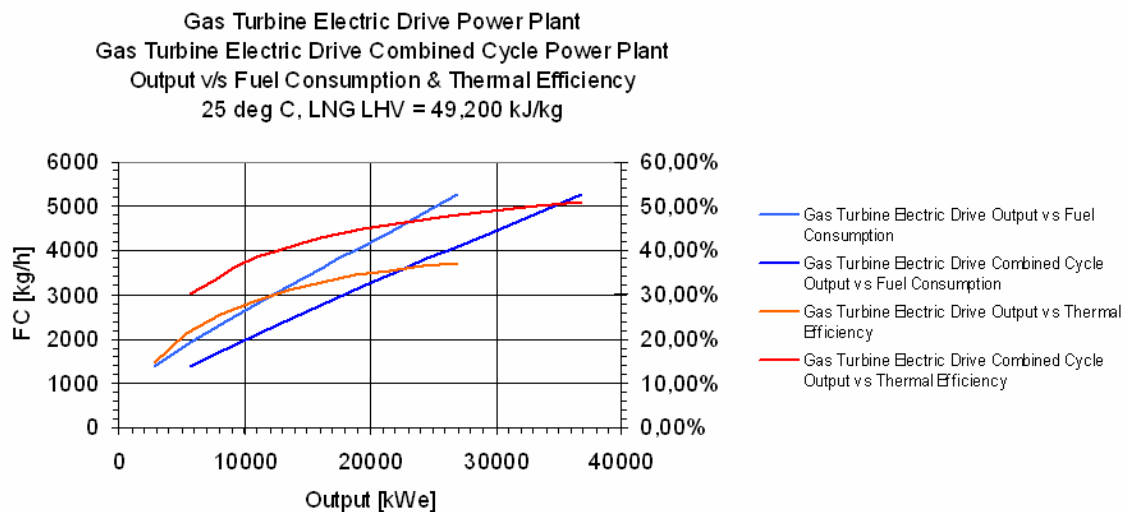

The free power turbine of the gas turbine drives the generator. The generator feeds into the main switchboard. The main switchboard feeds all electric consumers. The propeller is driven by a frequency controlled electric motor. The exhaust gasses from the gas turbine raise steam in an exhaust gas boiler. This steam is used to produce power in a 10 MWe steam turbine generator. The steam turbine generator also feeds into the main switchboard.

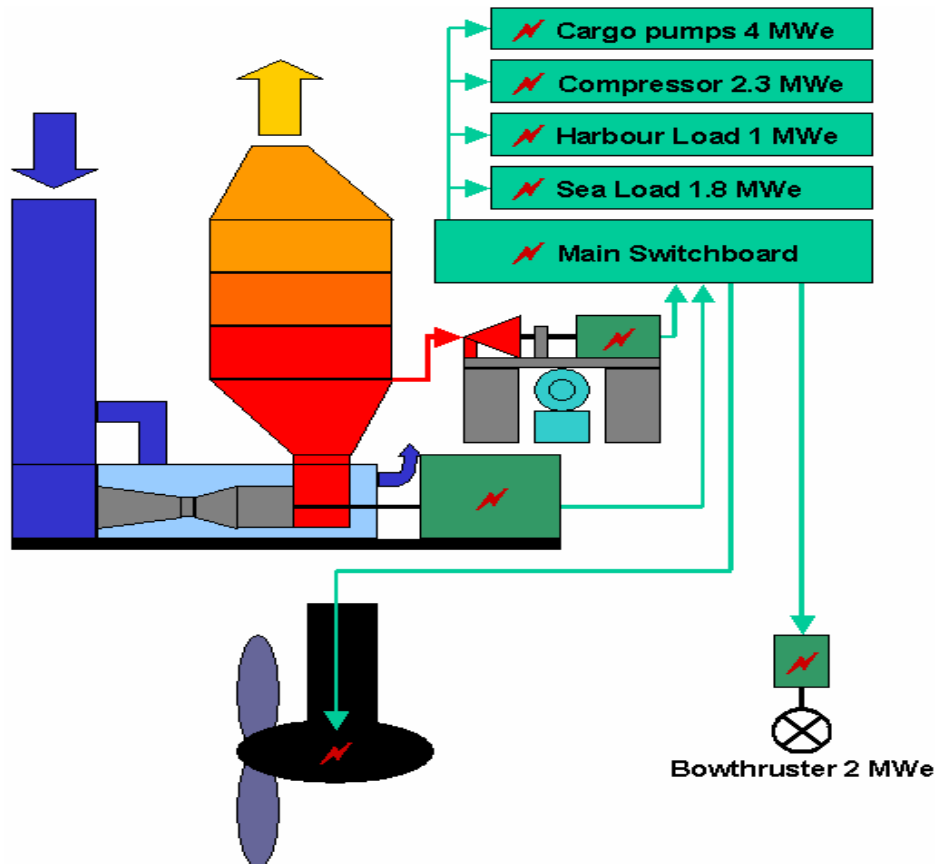

7.6.1 The advantages are:

- High thermal efficiency;
- Up to 17.4 % more cargo capacity;
- Increase propulsion efficiency through podded drives;
- Increased maneuverability;
- Propulsion and power generation redundancy;
- Dual-fuel capability;
- Lower hull construction cost;
- Low maintenance;
- Simplified engineroom arrangement, smaller steam system, smaller cooling water system;
- Reduced installation and commissioning time in the shipyard through factory assembled and tested package.

7.6.2 The disadvantage are:

Energy conversion losses in the electric drive system;
 Gas compressor required to supply gaseous fuel at 30 bar pressure to the gas turbine. Parasitic load can go up to 2.3 MWe;
 More complex and expensive than mechanical drive;

The operational profile of the power plant can be divided in a few distinct service modes:

7.7 Normal cruising speed:

7.7.1 Loaded:

The gas turbine generator is the prime mover, using the available BOG as primary fuel. Gas turbine exhaust gas heat is recovered in the boiler to generate steam. The gas turbine generator and the steam turbine generator feed the electric consumers from the main switchboard. The electric motor mounted on the propeller shaft drives the propeller.

7.7.2 In ballast:

Heel scenario: The gas turbine generator is the prime mover, using the available BOG as primary fuel. To make up the balance of the fuel requirements, extra LNG has been left in the tanks to be regassified when required. Gas turbine exhaust gas heat is recovered in the boiler to generate steam. The gas turbine generator and the steam turbine generator feed the electric consumers from the main switchboard. The electric motor mounted on the propeller shaft drives the propeller; Heel + liquid fuel scenario: The gas turbine generator is the prime mover, using the available BOG as primary fuel. To make up the balance of the fuel requirements, liquid fuel (MDO) will be supplemented. Gas turbine exhaust gas heat is recovered in the boiler to generate steam. The gas turbine generator and the steam turbine generator feed the electric consumers from the main switchboard. The electric motor mounted on the propeller shaft drives the propeller; Liquid fuel scenario: The gas turbine generator is the prime mover, using liquid fuel as primary fuel. Gas turbine exhaust gas heat is recovered in the boiler to generate steam. The gas turbine generator and the steam turbine generator feed the electric consumers from the main switchboard. The electric motor mounted on the propeller shaft drives the propeller.

7.7.3 Maneuvering:

The gas turbine generator is the prime mover, using the available BOG as primary fuel. The gas turbine generator and the steam turbine generator feeds into the main switchboard. The main switchboard supplies all electric consumers, including 4 MWe propulsion power to the propeller and 2 MWe bowthruster load; Should the gas turbine generator fail during maneuvering, can the steam turbine generator pick up the propulsion load. Steam for the steam turbine generator will be raised by firing the boiler on either BOG or liquid fuel or a mixture of both; Should the steam turbine generator fail during maneuvering, can the gas turbine generator supply the electric consumers through the main switchboard.

7.7.4 Harbour load:

The steam turbine generator is supplying the electric consumers through the main switchboard. Steam is being raised by firing the boiler on liquid fuel.

7.7.5 Cargo discharge:

The steam turbine generator is supplying the cargo pumps and the electric consumers through the main switchboard. Steam is being raised by firing the boiler on liquid fuel.

7.7.6 Emergency situations:

Should the gas turbine generator fail during the voyage, can the steam turbine generator provide approximately 8 MWe to the propeller shaft through the electric motor on the propeller shaft. Steam is being raised by firing the boiler on either BOG, BOG and liquid fuel or liquid fuel only, depending on availability. 8 MW propulsion power should keep the vessel maneuverable and she can proceed to the nearest port for repairs, should it prove impossible to remedy the problems at sea.

Should the steam turbine generator fail during the voyage, can the gas turbine generator supply the electric consumers through the main switchboard. With just over 4 MWe necessary for the electric consumers at sea, sufficient propulsion power remains to ensure good seakeeping and minimize delays in the schedule. If the problems can't be corrected at sea, spares and replacement equipment can be loaded at the next port of call.

7.8 Increasing LNG Carrier Cargo Capacity

The current cargo capacity of 138,000 cubic meter can be increased substantially when the engine room bulkhead and the aft cofferdam are moved further aft. Changing the overall length or the draft is not recommended, as some major LNG ports have size restrictions. Changing these parameters would impair the flexibility of the vessel. Gas turbine propulsion will allow a rearrangement of the engine room, since the gas turbine is much smaller than the steam turbine and its steam boilers.

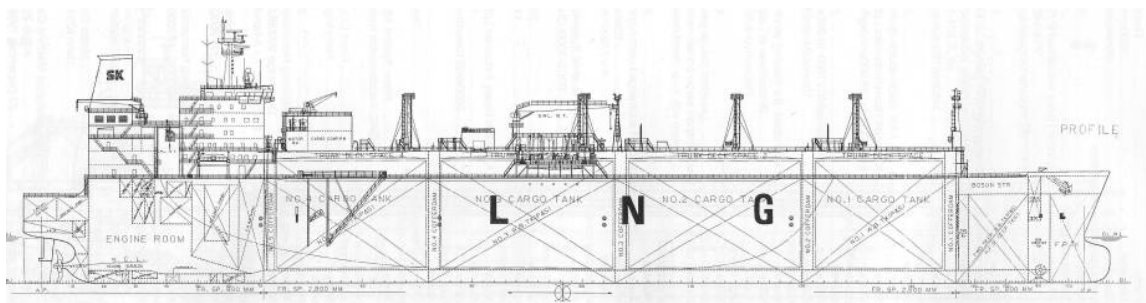

Moving the ER bulkhead aft from frame 71 to frame 45 extends the cargo hold by 20.8 meter. If the gain in gargo hold length is distributed over the four cargo tanks, an increase of 19,000 cubic meter in cargo capacity can be realised. The advantage of this version of the LNG carrier is that it can accommodate both gas turbine electric and gas turbine mechanical drive. The hull form does not have to be changed, so the redesign costs are minimal.

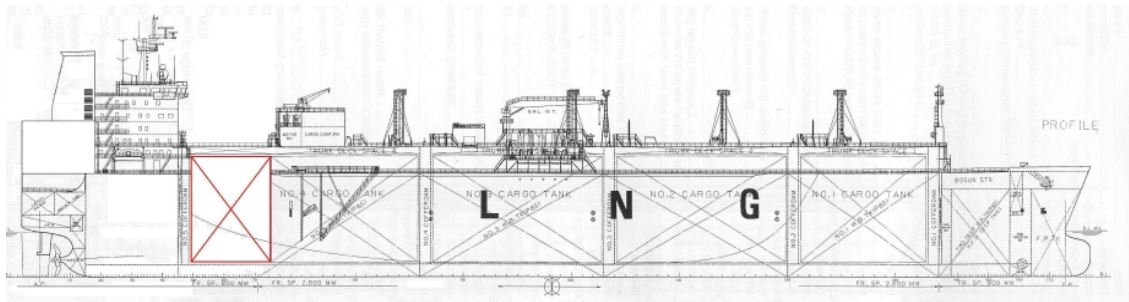

A total rearrangement of the LNG carrier would yield even better results. Cargo capacity would increase by 24,000 cubic meter over the standard design, while the increase thermal efficiency of the combined cycle gas turbine power plant brings fuel cost down by 40%. Increased propulsion efficiency from the podded drive system would bring fuel consumption down even further. Newbuilding cost can be reduced because of the simplified construction of the aft ship, without complex curves around the propeller boss.

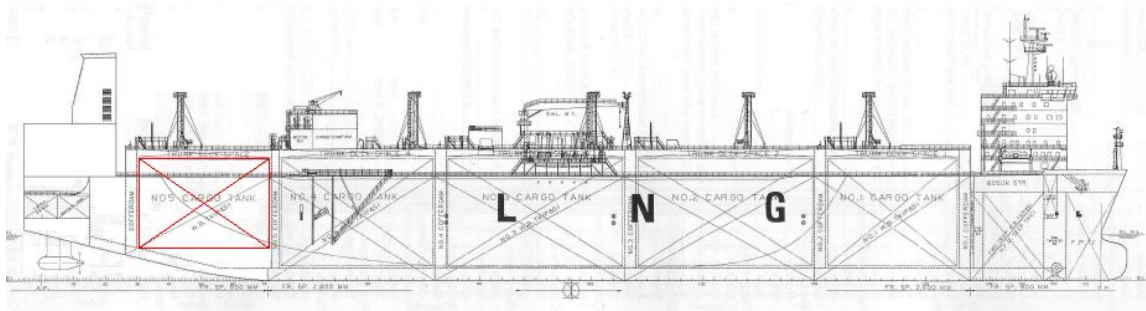

CHAPTER 8

RELIQUEFICATION TECHNOLOGY

While reliquefaction is widely used in gas handling on land, it has been used on board ship so far only on LPG carriers. Recently, the technology for reliquefying LNG on board ship has been matured and commercialised.

The present analysis is based on the Moss Reliquefaction, sold worldwide by Hamworthy KSE (Ref. [3]). The patented system (Moss RS) for reliquefying boil-off gas, establishes a solution for pumping LNG back to the tanks and selling more LNG to the buyers of gas.

The boil-off gas reliquefaction concept is based on a closed nitrogen cycle extracting heat from the boil-off gas. Several novel features such as separation and removal of incondensable components have resulted in a compact system with low power consumption. The concept has the following technical merits:

- The nitrogen in the LNG boil-off gas (BOG) is not reliquefied; this results in reduced nitrogen in the tanks during the voyage, better control of tank pressure and lower power requirement for the RS system.
- The system uses only proven components with extensive references from air-separation and peak-shaving plants world-wide.
- The system is prefabricated on skids for easy installation and hook-up.
- The system has automatic capacity control.
- The system can be stopped when the cargo pumps are in operation. This eliminates the need for extra generator capacity.
- During ballast voyage, the cargo tank temperature can be maintained by spraying reliquefied LNG back into the cargo tanks.
- The system must be installed with 100% redundancy.
- No extra personnel are required for operation and maintenance. The process can be described as follows:

The LNG boil-off is compressed by the low duty (LD) compressor (BOG compressor), and sent directly to the so-called cold box. The cold box in which the boil-off is reliquefied is cooled by a closed refrigeration loop (Brayton cycle). Nitrogen is the working medium. Fig. 21 shows the standard Moss RS reliquefaction system.

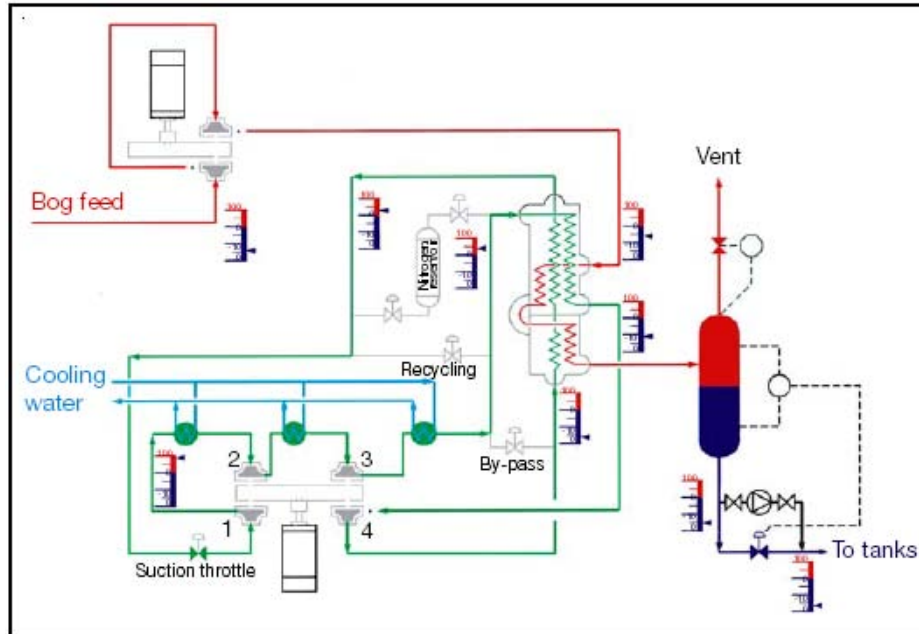

Standard Moss RS reliquefaction system

8.1 BOIL-OFF CYCLE:-

The cargo cycle consists of an LD compressor, a plate-fin cryogenic exchanger, a separator and an LNG return pump. Boil-off is evacuated from the LNG tanks by means of a conventional centrifugal low duty compressor. The vapour is compressed to 4.5 bar and cooled at this pressure to approximately -160°C in a plate-fin cryogenic heat exchanger.

This ensures condensation of hydrocarbons to LNG. The fraction of nitrogen present in the boil-off that cannot be condensed at this condition remains as gas bubbles in the LNG. Phase separation takes place in the liquid separator. From the separator, the LNG is dumped back to the storage tanks, while the nitrogen-rich gas phase is discharged (to atmosphere or burnt in an oxidizer).

8.2 NITROGEN CYCLE:-

The cryogenic temperature inside the cold box is produced by means of a nitrogen compression-expansion cycle, shown in Fig. Nitrogen gas at a pressure of 13.5 bar is compressed to 57 bar in a 3-stage centrifugal compressor. The gas is cooled by water (seawater or indirect) after each stage. After the last cooler, the gas is led to the "warm" part of the cryogenic heat exchanger where it is pre-cooled to about -110°C and then expanded to a pressure of 14.5 bar in the expander. The gas leaves the expander at about -163°C and is then introduced into the "cold" part of the cryogenic heat exchanger where it cools and reliquefies the boil-off gas to LNG.

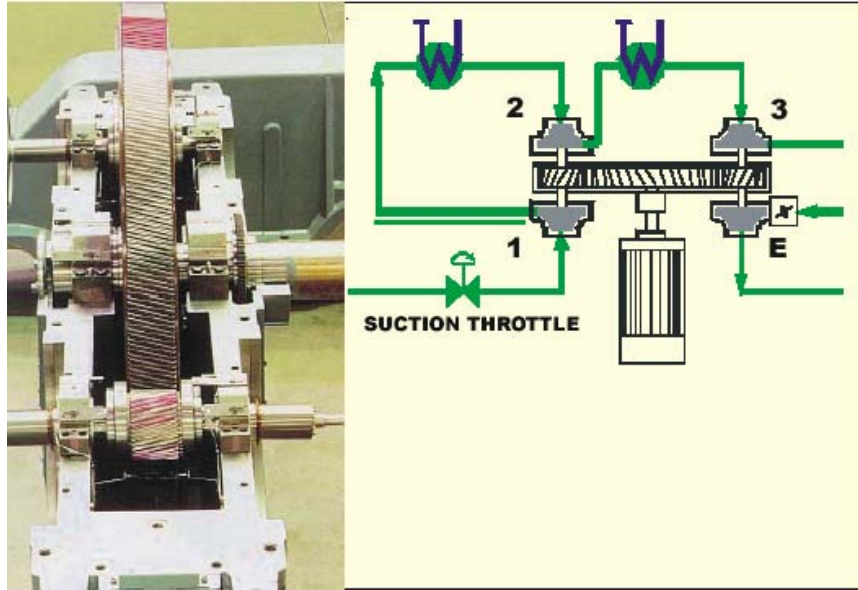

Nitrogen compressor/expander

The nitrogen then continues through the “warm” part of the cryogenic heat exchanger before it is returned to the suction side of the 3-stage compressor. The N₂-compressor/expander unit is three-stage integrated gear centrifugal compressor with one expander stage. The unit has a gear with 4 pinions where each of the 4 wheels is coupled to a separate pinion. The result is that the expander work goes directly into the gearbox and relieves the electric motor. The advantages of this solution are:

- **More compact design**
- **Reduced cost**
- **Improved control of the refrigeration**
- **Reduced power consumption.**

8.3 CONTROL SYSTEM:-

Generally, the temperature in the nitrogen loop decides the quantity of N₂ in the coolant circuit. Increasing or decreasing the amount of nitrogen in the loop changes the cooling capacity. The amount is changed by injecting or withdrawing nitrogen from the receiver. If the cooling capacity is too high, the inlet expander temperature will decrease. The control valve to the receiver at the compressors discharge will open to withdraw the nitrogen from the main loop. Correspondingly, if the cooling capacity is too low, the inlet expander temperature will increase. The control valve from the receiver to the compressor suction side will open to inject nitrogen into the main loop.

The relationship between cooling capacity and pressure changes is based on the fact that a turbo compressor is a constant volume flow machine. When the

suction pressure is changing, the mass flow is changing and, correspondingly, the cooling capacity. The pressure ratio for the compressor is constant and independent of the suction pressure. Even if the cooling capacity is reduced, the outlet expander temperature will be nearly the same.

The BOG cycle is an independent loop. The cargo tank pressure is kept approximately constant by varying the mass flow through the compressor. The boil-off compressor will be a two-stage centrifugal compressor with diffuser guide vanes (DGV) for controlling the capacity. There is DGV on both stages, and they work in parallel, controlled by the same signal.

8.4 REDUNDENCY:-

- Redundancy is required by the International Classification Society Association (IACS), as discussed later. The requirement is fulfilled if one of the following options is installed:
- Thermal oxidizer or flare system capable of burning the maximum boil-off rate.
- Two 100% reliquefaction plant with one cold box, comprising the following:

Two BOG-compressor units (two-stage centrifugal compressor) Two N₂-compressor/ expander units (three-stage integrated gear centrifugal compressor with one expander stage)

- One cold box
- One LNG phase separator
- One LNG forced return pump
- Auxiliary systems

Which one to operate of the two BOG-compressor units and N₂-compressor/ expander units can be freely chosen by operating the applicable valves. Change-over of equipment is done manually, and must be done only when the machinery is shut down. Simultaneous parallel operation of the equipment will not be possible.

As the reliability of today's steam turbine driven LNG carriers is considered high, an alternative system must not deteriorate the availability of the LNG carriers. The reliquefaction system therefore only uses proven components – first class, high quality with extensive references. The low-duty compressors in the RS system are the same as used on all LNG carriers today. The refrigeration cycle is in operation on the LNG carrier S/S LNG Jamal, and the 3-stage compressor with expander is operating on FPSOs and in onshore process plants.