

**DETROIT DIESEL**

---

**SERIES 60**



***Series 60 EGR  
Technician's Manual***

---



## **ATTENTION**

The information in this document is accurate as of **April 2004** and is subject to change without notice. This manual is to be used in conjunction with the *DDEC III/IV Single ECM Troubleshooting Guide* and the *DDEC V Single ECM Troubleshooting Guide*.

Series 60<sup>®</sup>, Detroit Diesel<sup>®</sup>, DDC<sup>®</sup>, DDEC<sup>®</sup> and the spinning arrows design are registered trademarks of Detroit Diesel Corporation. Diagnostic Link<sup>®</sup> is a registered trademarks of the Detroit Diesel Corporation.



## A LETTER TO TECHNICIANS

The Series 60 engine is entering its 14th year!

Since its introduction in 1987, over 729,000 Series 60 engines have been introduced in the market. The technological changes that have occurred during those 14 years have resulted in a different type of engine, requiring a different class of technicians. Today's technician is required to have computer skills, excellent comprehension of the written word and possess an extensive diagnostic understanding of the various technological systems and components. Today's technician must perform at a higher level of efficiency and competency than their predecessors and at the same time furnish professional quality support.

As the leader in engine computer systems and technology, Detroit Diesel Corporation remains focused on providing excellence in products, service support and training. As products become more and more advanced, today's technicians must become specialized in multiple areas. This manual is designed with that thought in mind. This Series 60 EGR Technician's Guide will provide you with concentrated information that will allow you to excel in EGR technology.

The *Series 60 EGR Technician's Guide* covers the October 2002 through current production Series 60 EGR engines.

After completing this guide you will:

- Understand the function of the Series 60 EGR engine components and their interdependence
- Understand Series 60 EGR operating modes
- Recognize the logic, component, and protection codes logged within the ECM
- Learn the acceptable pressure output values from a Variable Pressure Output Device (VPOD)
- Be able to record, playback, save, and e-mail a DDDL snapshot
- Apply your understanding of the EGR system logic to review DDDL diagnostic snapshots



# TABLE OF CONTENTS

1	INTRODUCTION .....	1-1
2	COMPONENTS .....	2-1
3	MODES .....	3-1
4	CODES .....	4-1
5	DDEC IV TESTING .....	5-1
6	DDDL/SNAPSHOTS .....	6-1
7	SNAPSHOT EXAMPLES .....	7-1
8	DDEC V COMPONENTS .....	8-1
9	DDEC V CODES .....	9-1
10	DDEC V TESTING .....	10-1
	APPENDIX A: LIST OF ACRONYMS .....	A-1
	APPENDIX B: DDEC IV WIRING SCHEMATICS .....	B-1
	APPENDIX C: ENGINE DIAGNOSTIC QUESTIONNAIRE .....	C-1
	APPENDIX D: SERVICE INFORMATION LETTERS .....	D-1





# 1 INTRODUCTION

The *Series 60 EGR Technician's Guide* is intended to be used by a qualified service technician familiar with Detroit Diesel electronically controlled (DDEC) diesel engines and to provide a better understanding of the EGR system to improve the diagnosing of a Series 60<sup>®</sup> EGR system.

**NOTE:**

The Series 60 EGR system will be supported in the near future.

Prerequisites for effective diagnosis include the following topics:

- Knowledge of both the engine and vehicle principles of operation.
- Ability to perform and to understand service manual and troubleshooting manual procedures.
- Availability and training to use gages and diagnostic test equipment.
- Familiarization of the computer software associated with DDC products.

An essential tool to properly diagnose and troubleshoot a DDEC IV or DDEC V Series 60 EGR engine is the Detroit Diesel Diagnostic Link<sup>®</sup> (DDDL).

This tool will provide you all the help you will need as it contains proper troubleshooting information for all products.

**NOTE:**

It is absolutely **critical** that you understand the EGR system to be qualified to offer any type of proper diagnostics. Do not **waste time** trying to troubleshoot a DDC product, you are not qualified to troubleshoot. Your company may incur wasted labor hours. If you are qualified to perform a troubleshooting task and have spent more than one hour on that task, **STOP**, and contact DDC Technical Assistance. Once you have discussed your options with a technical support person, you can perform the required tests and evaluations. Please keep in contact with your technical support person. This allows you to stay on track.

## BASICS

The following listed items should be checked prior to starting any troubleshooting:

- Ensure engine serial number on the ECM matches the serial number on the cylinder block.
- Walk around the vehicle. Look for obvious problems such as leaks (air or liquid).
- Inspect the ECM for worn isolators, debris or bolts lodged between ECM and cylinder block.
- Ensure the fuel supply shut-off valve is set to *full on*.
- Check that the fuel filter is secure and tight.
- Check for a restricted air filter.
- Inspect truck frontal area for air flow restriction through the CAC and radiator.
- Ensure that the fuel tank level is correct and that the fuel tank is full.
- Look for any vehicle damage.
- Investigate any prior repairs, if applicable.
- Check for broken wiring connectors.
- Check for poor mating of the connector halves or terminals not fully seated in the connector body (backed out terminals).
- Look for improperly formed or damaged terminals. All connector terminals in the problem circuit should be carefully inspected to determine proper contact tension. Use a mating terminal to test the contact tension.
- Check for electrical system interference caused by a defective relay, ECM driven solenoid, or a switch causing an electrical surge. Look for problems with the charging system (alternator, etc.). In certain cases, the problem can be made to occur when the faulty component is operated as in the case of a relay.
- Verify that alternator grounds are clean and making good contact. Disconnect the alternator belt to test.
- Wiggle wires and harnesses to try to make the problem active, or re-occur.

## OPERATOR INFORMATION

This section should serve as a guideline for the technician:

- Intermittent Problems - Talk to the operator/driver. **Be specific!**
- Develop your own Driver Questionnaire (see Figure 1-1).

### **NOTE:**

A full page copy of the questionnaire can be found in Appendix C.

<b>Engine Diagnostic Questionnaire</b>		<b>RO #</b> _____		
Customer Name: _____				
Contact Person: _____				
<b>LOW POWER/POOR FUEL ECONOMY:</b>				
Does check engine light come on?	Yes	No		
Does the engine miss, run rough, hard starting?	Miss	Run Rough	Hard Starting	
Power Loss sudden or has decreased with time?	Sudden	Decreased with time		
Excessive engine exhaust smoke (see #3)?	Yes	No		
If yes, what color?	Black	Blue	White	
Heard any unusual engine noise? Yes _____		No		
Power loss occurs on	Foot	Cruise	Both	
Have injectors been replaced recently?	Yes	No		
When was last tune up? Mileage _____ Date _____				
Comments: _____				
<b>ANY INTERMITTENT PROBLEMS:</b>				
Last time it happened: _____				
Does the check engine light come on?	Yes	No		
Does the problem occur only in damp or rainy conditions?	Yes	No		
When the vehicle hits a bump or rough road?	Yes	No		
Does the engine:	Miss	Drop to idle	Quit running	
	Gauge Sweep	Hard Starting		
Comments: _____				
e.g. Does the driver do anything to correct the problem? _____				
<b>SMOKING:</b>				
Where is the smoke coming from? _____				
What color is the smoke?	Blue	Black	White	Bl/White
When does it smoke?	Start-up	Cold Eng.	Hot Eng.	U Load
Have you noticed any oil consumption?			Yes	No
Have you noticed a miss in the engine?			Yes	No
Was the smoke intermittent?-	Start all at once?	Been getting worse over time?		
Comments: _____				
<b>COOLANT LOSS</b>				
Has the oil level risen?	Yes	No		
Have you noticed any coolant leaks?	Yes	No		
How often do you add coolant? _____	How Much? _____			
What kind of coolant do you use? _____				
What kind of inhibitor do you use? _____				
Comments: _____				
<b>OIL CONSUMPTION:</b>				
How much oil are you adding? _____	How often (miles)? _____			
Have you noticed any oil leaks?	Yes	No		
Have you noticed any smoke out the exhaust?	Yes	No		
	At Idle	Light or no load	Heavy load	
How often do you change oil? _____	What Brand? _____			
Have you changed brands recently?	Yes	No		
How & when do you check your oil? _____				
Comments: _____				

44272

Figure 1-1 Drivers Questionnaire

## Driver Questionnaire

Ask the driver to answer the following questions before attempting to repair an intermittent problem, or a problem with symptoms but no diagnostic codes. Use this and the response as a guideline. Refer to *Questionnaire Response Guideline* found on page 1–6.

1. How often does the problem occur? Can you and the driver take the vehicle and demonstrate the problem in less than 30 minutes?
2. Has the vehicle been to other shops for the same problem? If so, what was done there?
3. Did the radio, dash gages, or lights momentarily turn OFF when the problem occurred?
4. Does the problem occur only at specific operating conditions? If so, at what load? Is it light, medium, or heavy?
5. Does the problem occur at a specific engine operating temperature? If so, at what engine temperature?
6. Does the problem occur at a specific engine operating altitude? If so, at what altitude?
7. Does the problem occur only when above or below specific outside temperatures? In what temperature range?
8. Does the problem occur during other conditions e.g. during or after rain, spray washing, snow?
9. Did the problem occur at a specific vehicle speed? If so, at what vehicle speed?
10. Does the problem occur at specific engine RPM? If so, at what engine RPM?

## Questionnaire Response Guideline

The following are typical responses to the Driver Questionnaire:

 <b>WARNING:</b>
<b>PERSONAL INJURY</b>
<b>To avoid injury from loss of vehicle/vessel control, the operator of a DDEC equipped engine must not use or read any diagnostic tool while the vehicle/vessel is moving.</b>

1. If the problem is repeatable, take the vehicle for a drive with the DDDL connected and note the conditions when the problem occurs. Be prepared to take snapshot data using the DDDL. **Ensure you operate the vehicle after correcting the problem and duplicate the operating conditions before releasing the unit, to verify the problem is corrected.**
2. If the vehicle has been to other shops for the same problem, call the other shops and find out what has been done. Avoid replacing the same components again unless absolutely sure they are the problem! It is unlikely a component will fail again following a recent replacement.
3. If other vehicle devices are affected, this indicates there may be something wrong with the ignition wiring.
4. Operate the engine under similar load conditions. Check the fuel system for restrictions, primary filter, and fuel tanks for foreign objects blocking the fuel supply. Also, check the air system. Utilize the DDDL snapshot feature.
5. Operate the engine at this temperature while attempting to duplicate the problem. Use the snapshot feature on the DDDL.
6. If possible, troubleshoot the problem in this temperature range.
7. If the problem seems to occur during or after the engine is subjected to rain/spray washing, thoroughly inspect the connectors for moisture entry.
8. If the problem occurs at a specific vehicle speed, check the parameters affecting vehicle speed to verify they are programmed close to the vehicle speed where the problem occurs. Check Vehicle Speed and watch the DDDL (snapshot) for changes to see if the pulse wheel (VSS signal) is loose.
9. If the problem occurs at a specific engine rpm, unplug the oil, coolant, and air temperature sensors, and note any changes to the problem. Gather this data and contact Detroit Diesel Technical Service.

## 2 COMPONENTS

The purpose of the EGR system is to reduce engine exhaust gas emissions in accordance with EPA regulations.

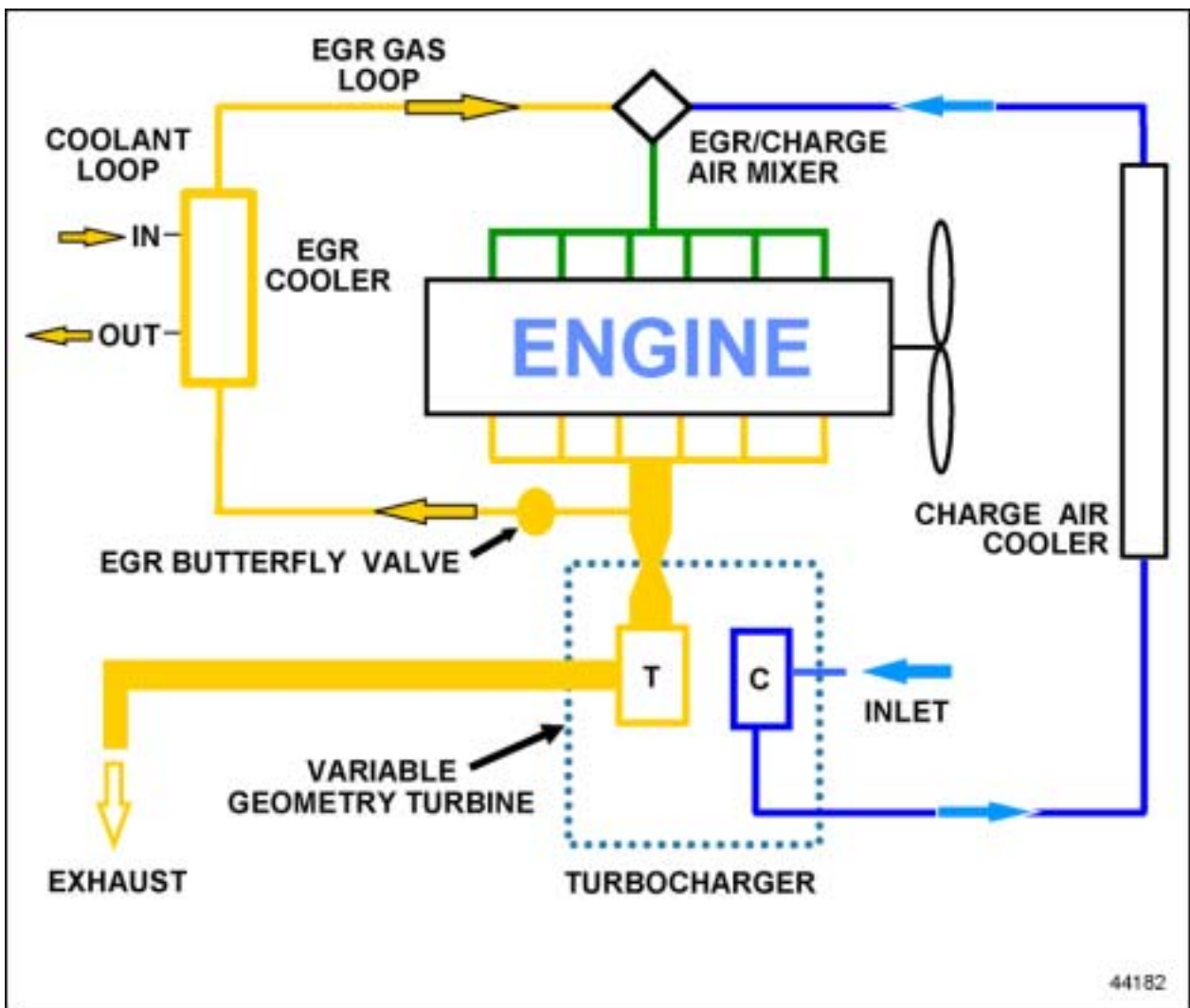
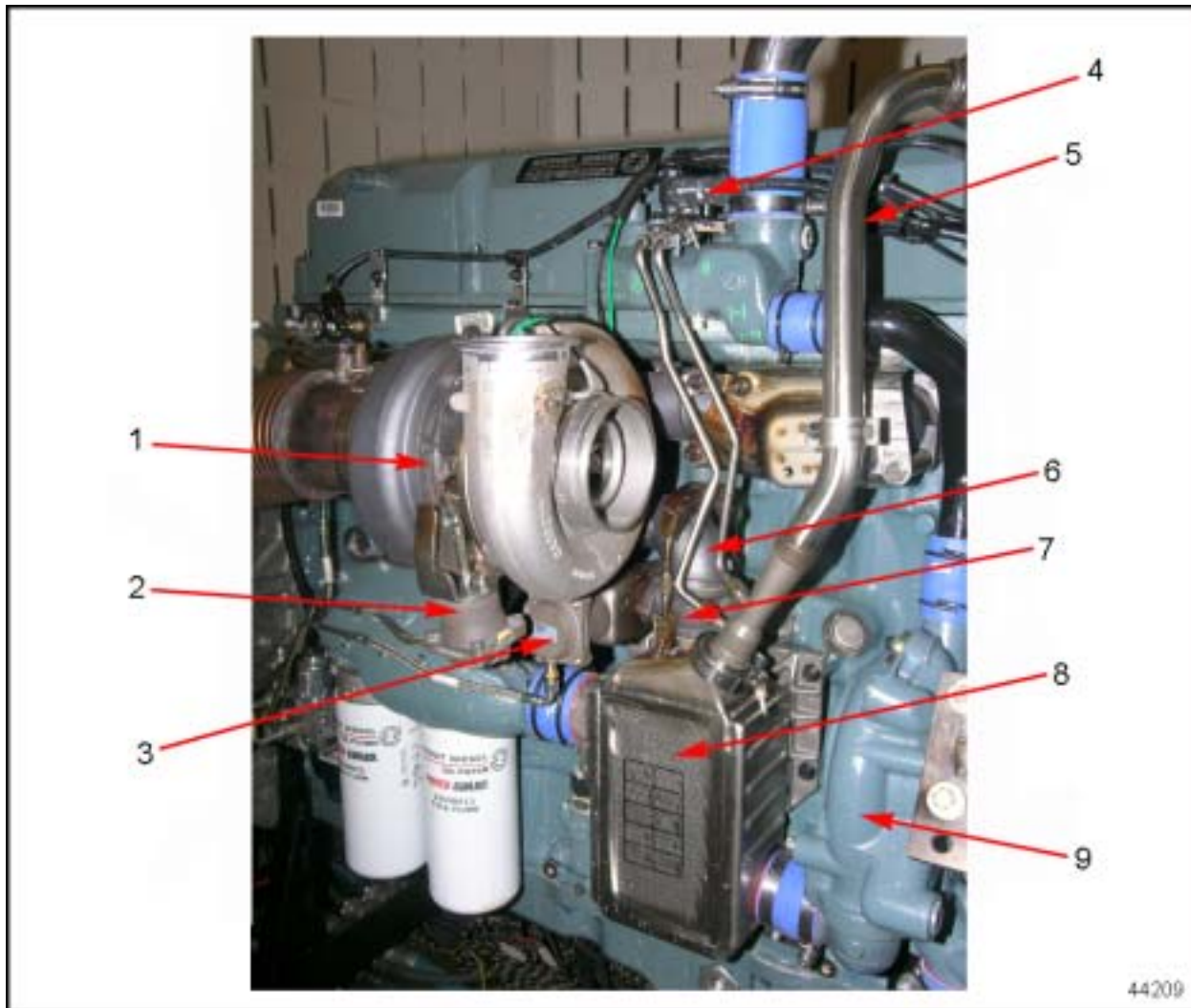

Figure 2-1 EGR System

EGR (exhaust gas recirculation) allows a percentage of the exhaust gases to remix with the air coming into the intake manifold. The exhaust gas dilutes the incoming air, displacing some of the oxygen in the air. Less oxygen results in a slower burn and a reduced peak cylinder temperature which reduces NOx (nitrogen oxides).

Figure 2-1 illustrates how components of the EGR system function.

See Figure 2-2 and Figure 2-3 to familiarize yourself with the EGR components.



- |                          |                         |
|--------------------------|-------------------------|
| 1. VNT Turbocharger      | 6. S Pipe               |
| 2. Turbo Vane Actuator   | 7. EGR Valve            |
| 3. EGR Valve Actuator    | 8. EGR Cooler           |
| 4. Delta Pressure Sensor | 9. High Flow Water Pump |
| 5. EGR Gas Delivery Pipe |                         |

**Figure 2-2 Right Side View**



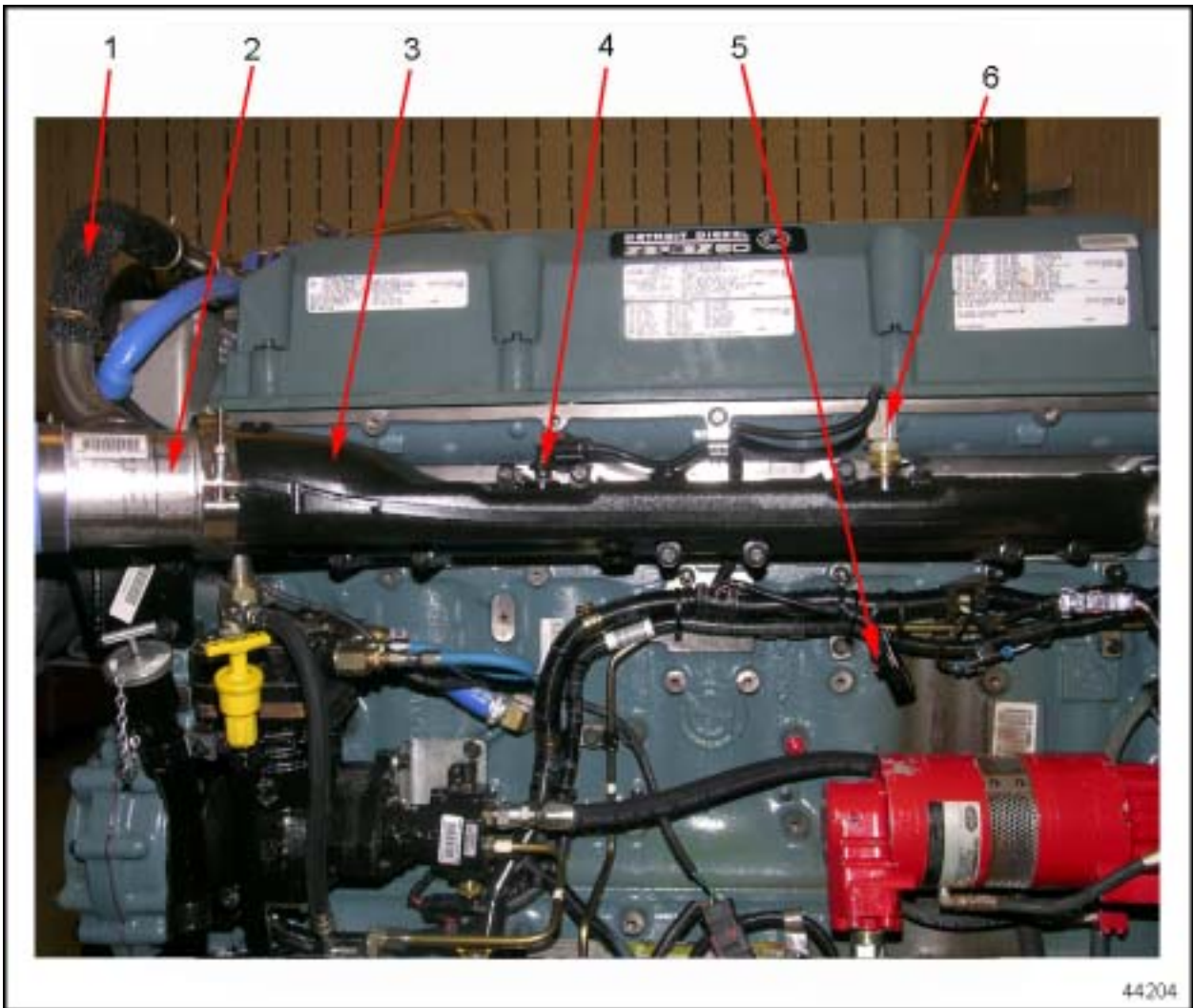

- |                          |   |
|--------------------------|---|
| 1. EGR Gas Delivery Pipe | 4. Intake Manifold Air Temperature Sensor |
| 2. EGR Mixer             | 5. Barometric Pressure Sensor             |
| 3. Intake Manifold       | 6. Intake Manifold Boost Pressure Sensor  |

**Figure 2-3 Left Side View**

**FUNCTIONALITY OF THE EGR COMPONENTS**

**Variable Pressure Output Device (VPOD)**

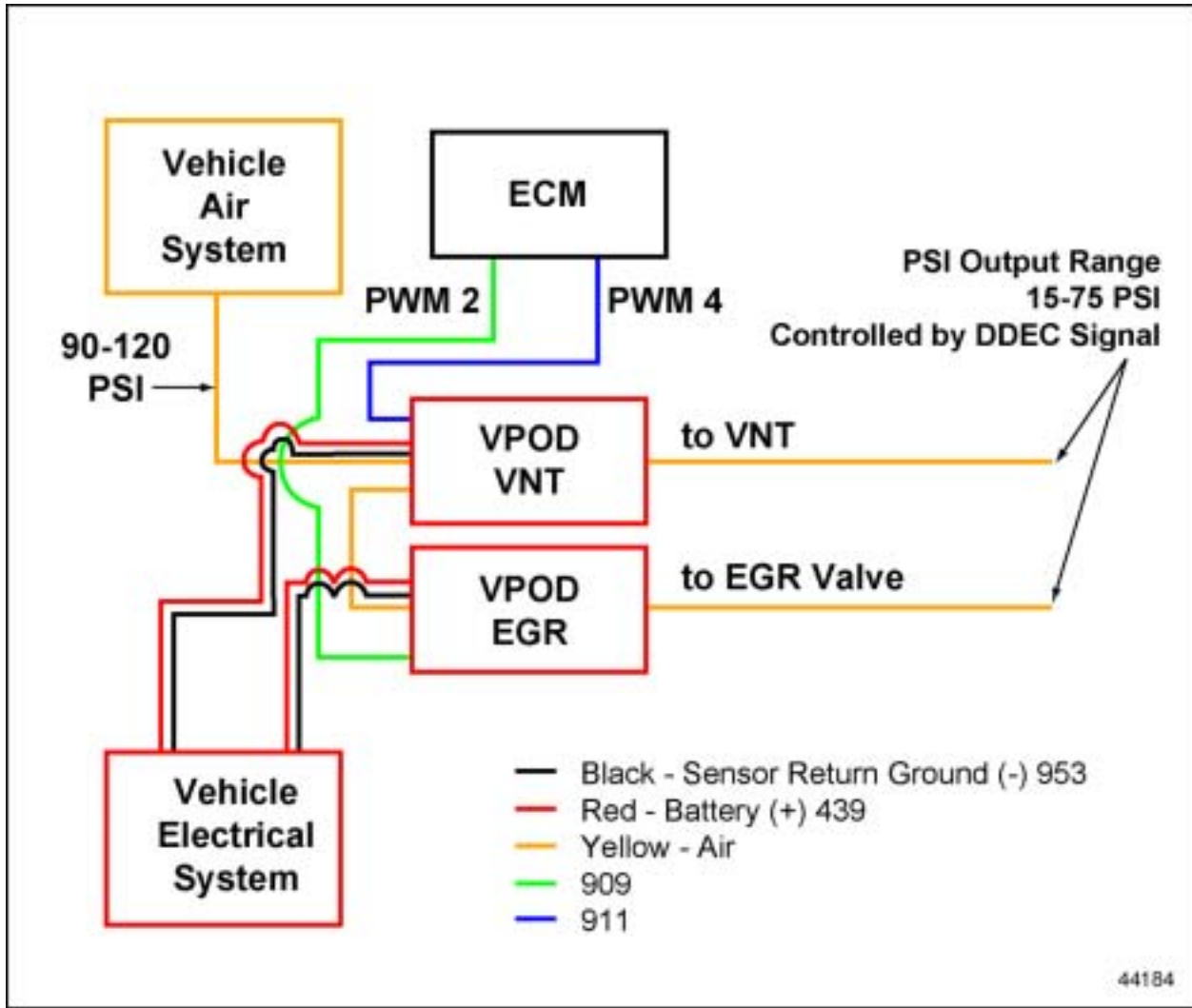

12 V/24V power supply system  
 DDEC IV ECM: PWM2 (Y1) EGR and PWM4 (X2) VNT

**Figure 2-4 EGR Valve and VNT Control System**

There are two Variable Pressure Output Devices (VPOD) that control the Variable Geometry Turbo (VNT) and the EGR system. The location of the VPODs is application dependent. During engine EGR operation, the VPOD provides modulated air pressure to the pneumatic actuators which change the VNT vanes and EGR valve positions. The VPOD interface with other systems may be viewed in see Figure 2-4.



## Variable Nozzle Turbocharger (VNT)



**Figure 2-5** VNT Turbocharger

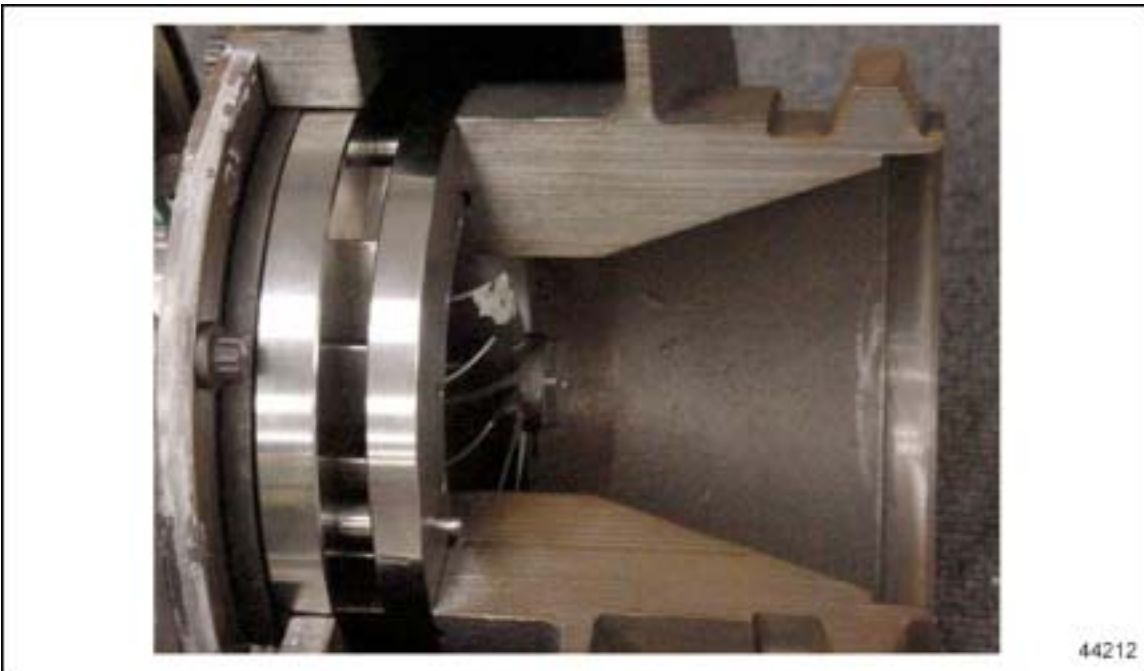

**Figure 2-6** Cut Away View of the Vanes

The results of being able to adjust like this are as follow. See Figure 2-5 and see Figure 2-6.

- Enhanced air/fuel ratio during engine acceleration

- Provides EGR transport mechanism in EGR mode
  - More vane closure increases the EGR flow rate (PWM % is high).
  - Less vane closure decreases the EGR flow rate (PWM % is low).
- Provides enhanced engine brake capability.

The VNT vanes adjust to control the exhaust gas velocity. See Figure 2-7.

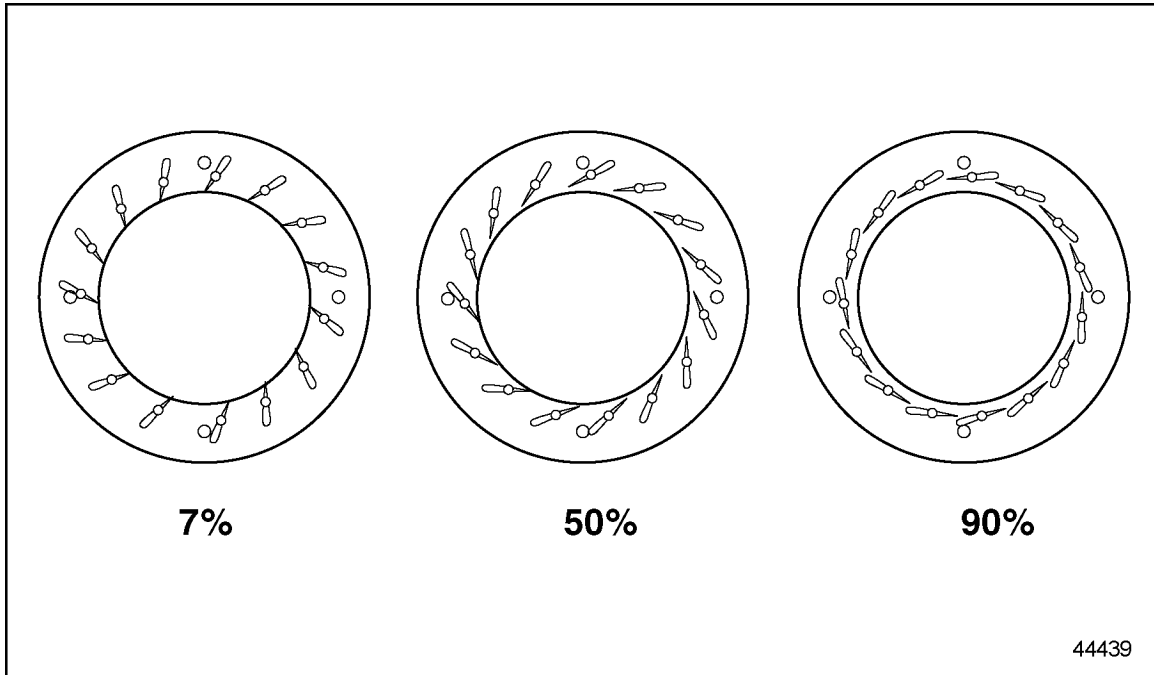

**Figure 2-7 VNT Vane Position**

**Vane Position During Engine Operation**

**PWM 7%**

No air pressure to VNT actuator from the VPOD

Minimum exhaust restriction/Minimum EGR flow while operating in EGR Mode

**PWM 50%**

Regulated air pressure to the VNT actuator from the VPOD

Moderate exhaust restriction

Increased EGR flow while operating in EGR Mode

**PWM 90%:**

Maximum regulated air pressure to the VNT actuator from the VPOD

Maximum regulated exhaust restriction/Maximum EGR flow while operating in EGR Mode

## EGR Valve

The valve position is controlled by DDEC. The ECM continuously monitors all engine operation modes and performs self diagnostic checks of RPM, load, altitude, air temperature, etc. and uses this information to determine the valve position.

When the EGR valve is closed, exhaust flow from the exhaust manifold, past the turbine wheel in the turbocharger and out the exhaust system, in the traditional way.

When the valve is open, some of the exhaust gas is directed into the EGR cooler, through the delivery pipe and into the intake manifold.

## EGR Valve Actuator



**Figure 2-8 EGR Valve Actuator**

The EGR valve regulates the EGR flow rate via air pressure input from the VPOD. The EGR valve has the following components (see Figure 2-9):



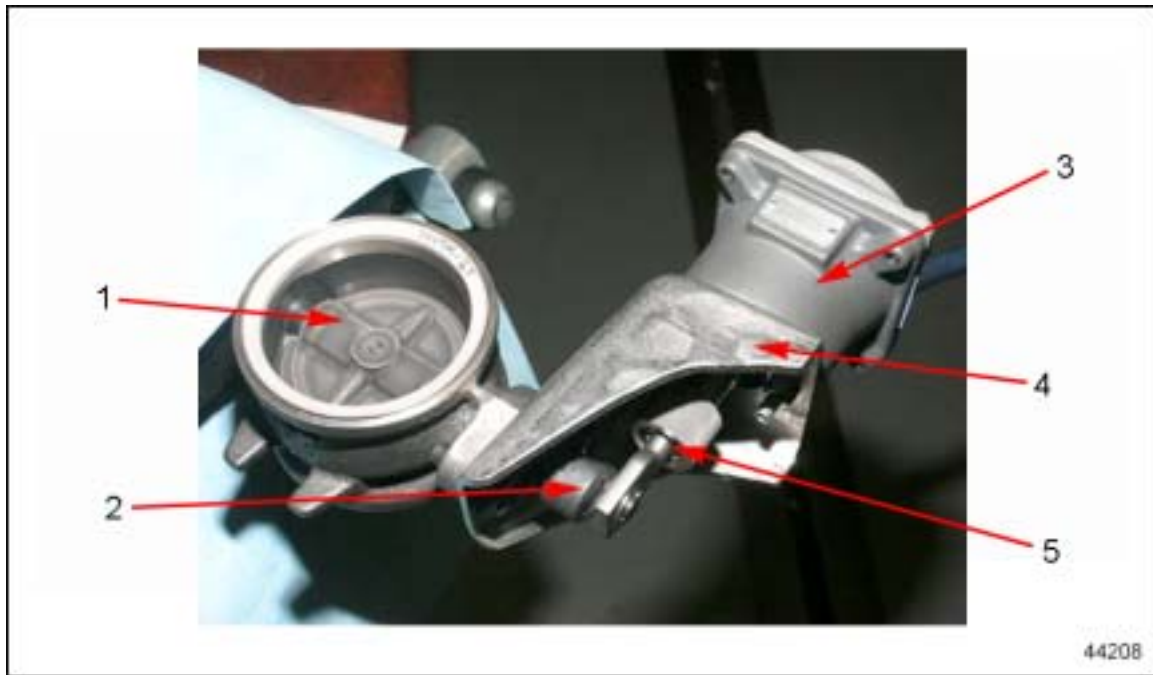

- 1. Butterfly Valve
- 2. Splined Crank Arm
- 3. Pneumatic Actuator
- 4. Actuator Bracket
- 5. Adjustable Linkage

**Figure 2-9**

**EGR Cooler**

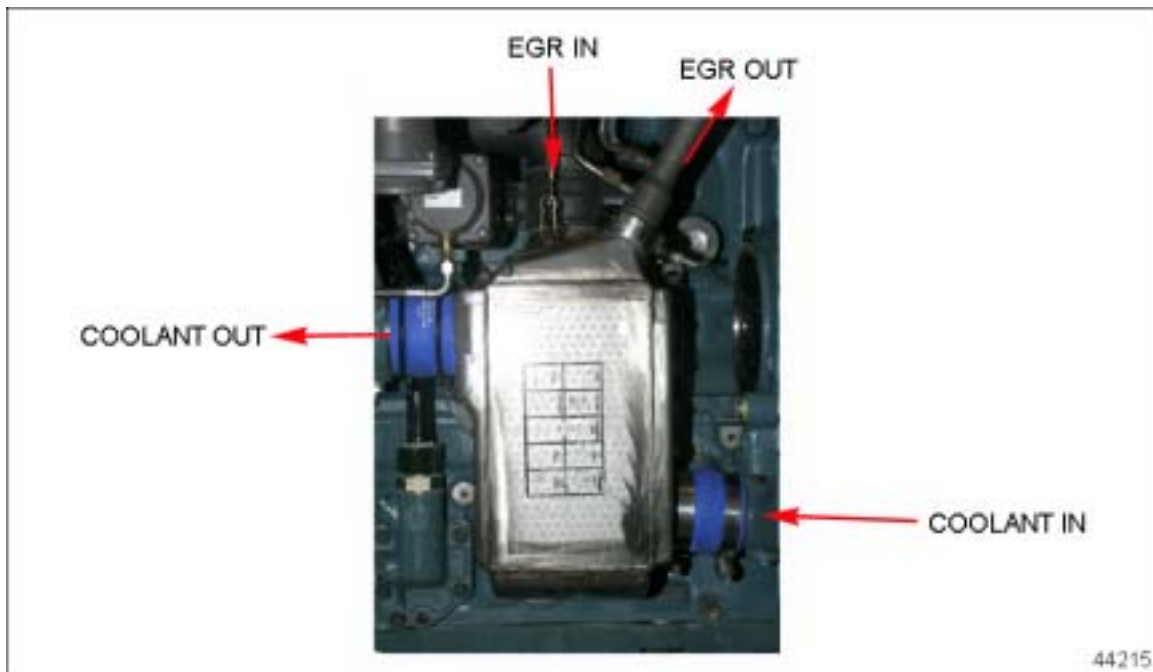

**Figure 2-10 EGR Cooler (Bar and Fin Design)**

The primary purpose of the EGR cooler (see Figure 2-10), is to cool the exhaust gases by:

- Providing a coolant flow to remove heat from the gas side core.

### Delta Pressure Sensor/EGR Temperature Sensor



**Figure 2-11 Venturi**

Monitoring the pressure differential across the venturi (adjacent to outlet of EGR cooler see Figure 2-11 and see Figure 2-12) and the temperature of the exhaust gases (see Figure 2-13) determine precise Mass Flow Rate Measurement.

The ECM uses the delta pressure and exhaust temperature to determine the rate of EGR flow.





**Figure 2-12 Delta Pressure Sensor**

The Delta Pressure Sensor measures the pressure difference across the venturi in the transfer pipe.

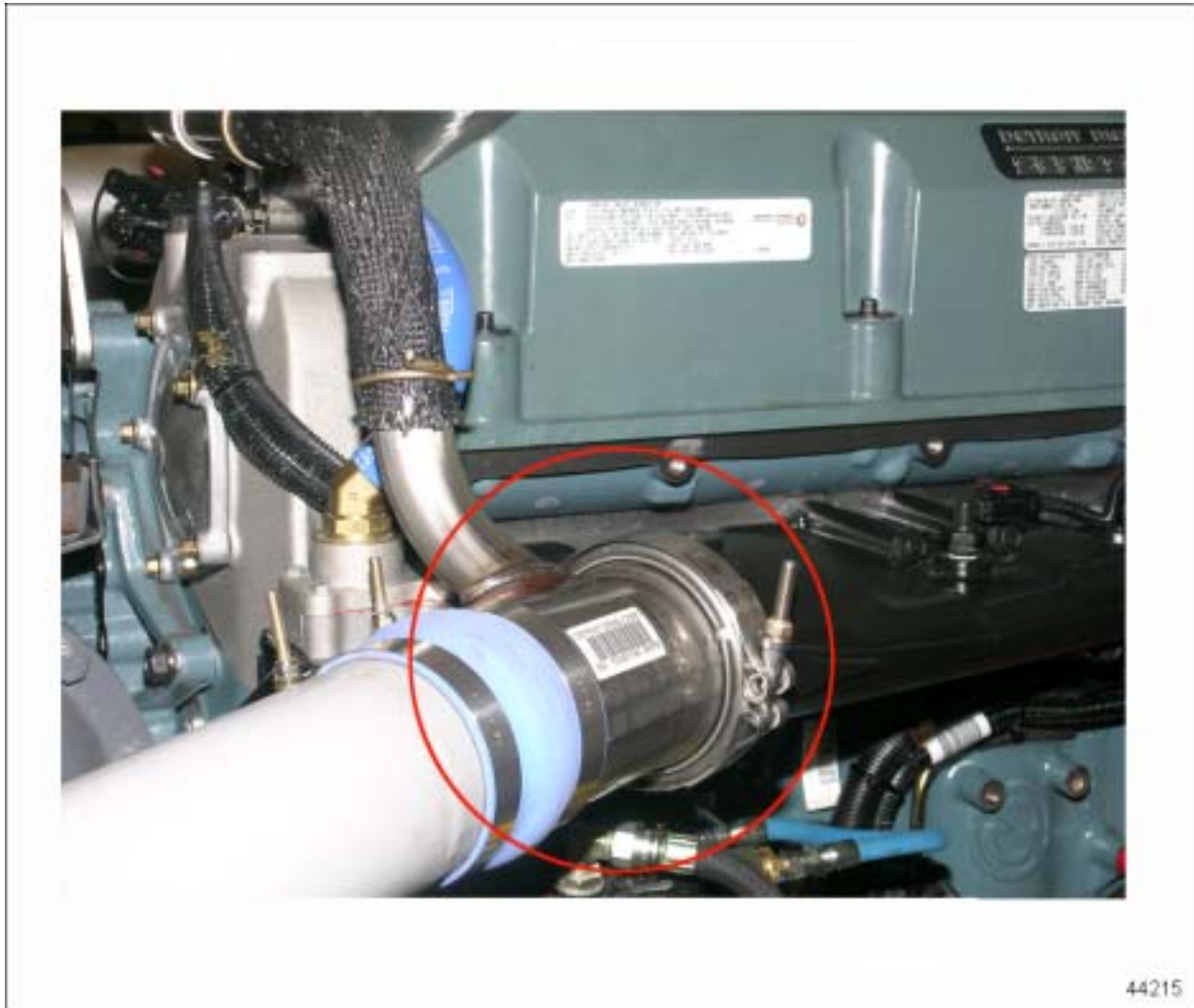

**Figure 2-13 EGR Temperature Sensor**

## EGR Gas Delivery Pipe/Mixer

The delivery pipe provides the path for the EGR gases to flow from the EGR cooler to the intake manifold.

### Mixer



**Figure 2-14 EGR Mixer**

The mixer completes the EGR circuit. See Figure 2-14.

The mixer mixes exhaust gas into the fresh air supply flowing from the charge-air-cooler. Once the air has past the mixer, the intake manifold defuses EGR gas evenly to each cylinder. Sensors are mounted in the intake manifold to monitor the air temperature and the boost pressure.

## High Flow Water Pump

The EGR engine uses a high flow water pump to improve the coolant flow for added heat dissipation.

**NOTE:**

The high flow water pump is not interchangeable with a non-EGR engine.



## 3 MODES

### OPERATIONAL MODES

New terminology has been introduced as a result of the Series 60 EGR engine.

#### **Boost Mode**

Boost Mode is when the engine is generating power with **NO EGR** flowing. The EGR valve position is closed and the vanes in the turbocharger adjust to achieve a desired boost level. Boost levels are similar to 'pre-EGR' engines.

#### **Transition from Boost to EGR Mode**

Transition from Boost to EGR Mode is when the engine is generating power using boost pressure and DDEC requests EGR to begin flow.

#### **EGR Mode**

EGR Mode occurs when DDEC is flowing EGR at a desired rate to maintain proper engine operation. The EGR valve position is open and vanes in the turbocharger adjust to achieve the desired EGR rate. Typically boost levels are higher under this operating mode when compared to 'pre-EGR' engines.

#### **EGR Control Mode**

EGR Control Mode occurs when the DDEC engine sensors are performing normally and all engine parameters are within calibration limits as determined by the sensor readings. These readings enable DDEC to accurately control exhaust gas flow.

#### **Transition from EGR to Boost**

Transition from EGR to Boost Mode occurs when the engine is generating power while flowing EGR and DDEC requests to close the EGR valve and generate power based upon boost pressure.

#### **Braking Mode**

Braking Mode occurs when the engine is absorbing energy (power) through an internal engine-braking device. The power for the engine brake is accomplished by activating the desired number of cylinders and adjusting the vanes in the turbocharger to achieve the desired boost level. The EGR valve position is closed during brake mode.

## **Altitude**

The engine will transition between EGR and boost mode at an altitude of 6500 ft. Altitude is determined by the Barometric Pressure Sensor located on the engine. See Figure 2-3.

## **Condensation Protection**

In very cold ambient (i.e. < 30F) conditions the engine will operate in a "condensation protection" mode. EGR is disabled during this mode requiring a slower turbo speed. The engine will sound "different". During this mode of operation the operator will notice a lower "boost" reading compared to when EGR is active, however there is NO reduction of power.

## EGR SYSTEM

In this section, various colors are used to illustrate a particular engine mode for the Series 60 engine. The meaning of each color is defined in the list below.

- Red** = Exhaust Gas
- Blue** = No EGR Flow
- Green** = Coolant Flow
- Yellow** = Vehicle Air (VPODs)
- Orange** = Cooled Exhaust Gas

## Boost Mode

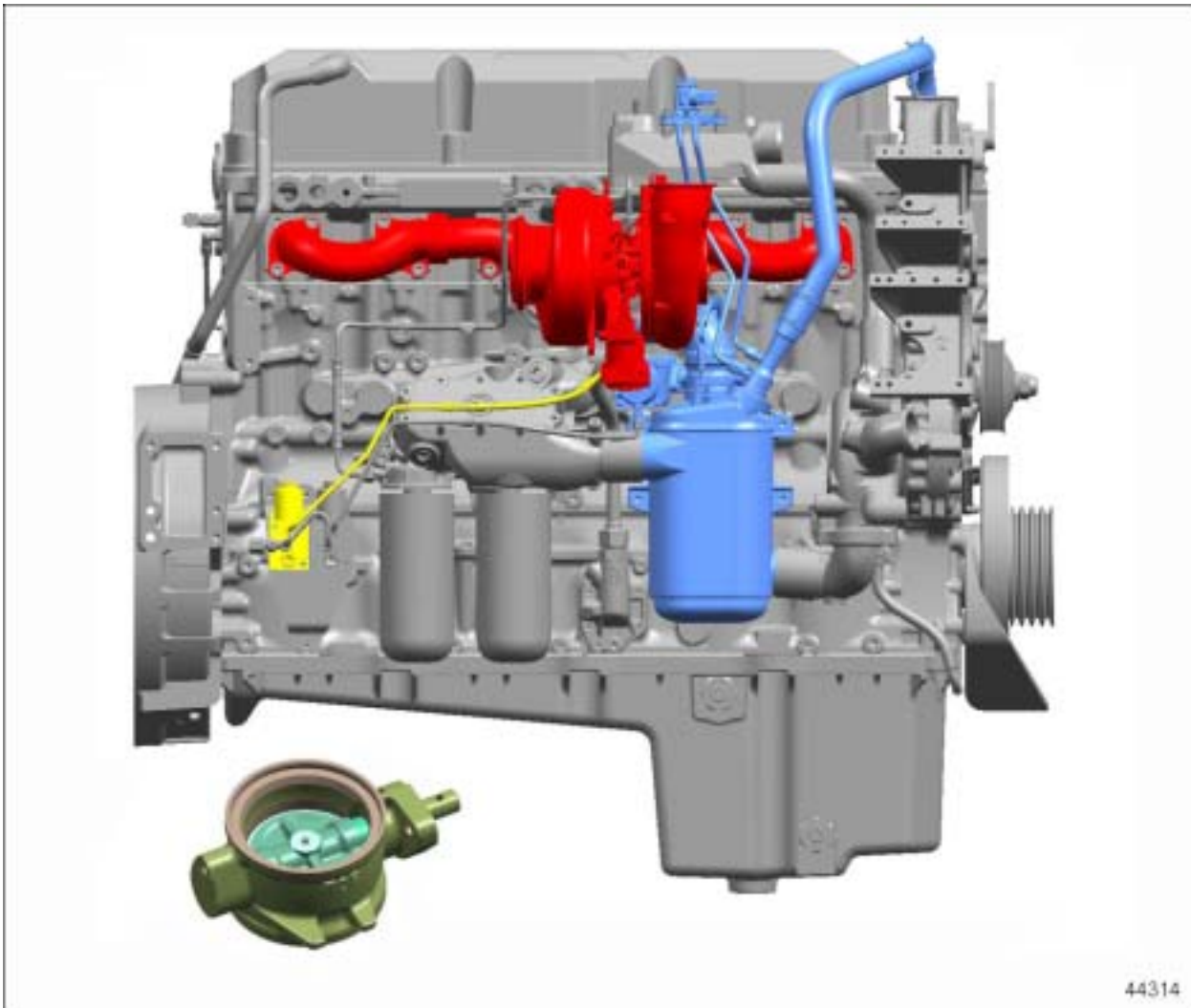

During Boost Mode the following occurs:

- EGR valve closed
- No EGR flowing through the EGR cooler or delivery pipe
- VNT vane position controlled by intake manifold boost pressure and limited by the turbocharger speed



### **Boost Mode Operation**

A typical Boost Mode operation consists of:

- Accelerating a vehicle from stationary position and shifting up through the transmission gears.
- Performing engine brake operation.
- The vehicle is at or above 6500 ft of altitude.
- High ambient humidity to prevent condensation of EGR gases in the intake manifold.

### **EGR Valve Activated by DDEC IV**

#### **Transition from Boost to EGR Mode**

Initiation of EGR requires minimum engine speed and boost pressure (air flow) in order to transition into EGR mode without an abrupt drop in air/fuel ratio.

Once minimum RPM and boost levels are attained the ECM sends a signal via PWM#2 to initiate the valve opening event by providing air pressure to the EGR actuator.

## EGR Valve and Pneumatic Actuation

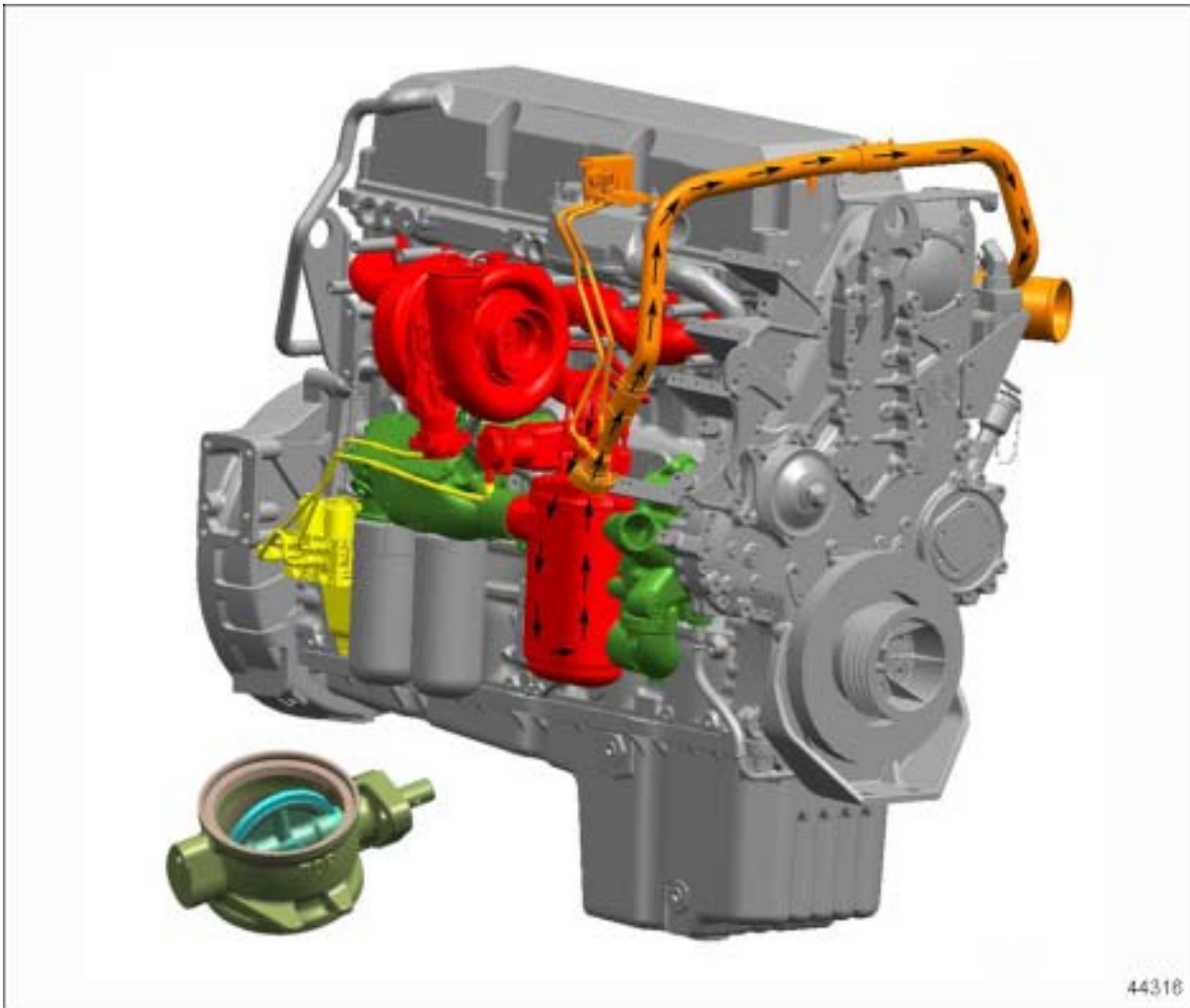

Air pressure supplied by the EGR VPOD to the EGR actuator opens the butterfly valve. Once the EGR butterfly valve opens, the EGR flows through the EGR cooler and into the delivery pipe.

## EGR Cooling

### EGR Cooling

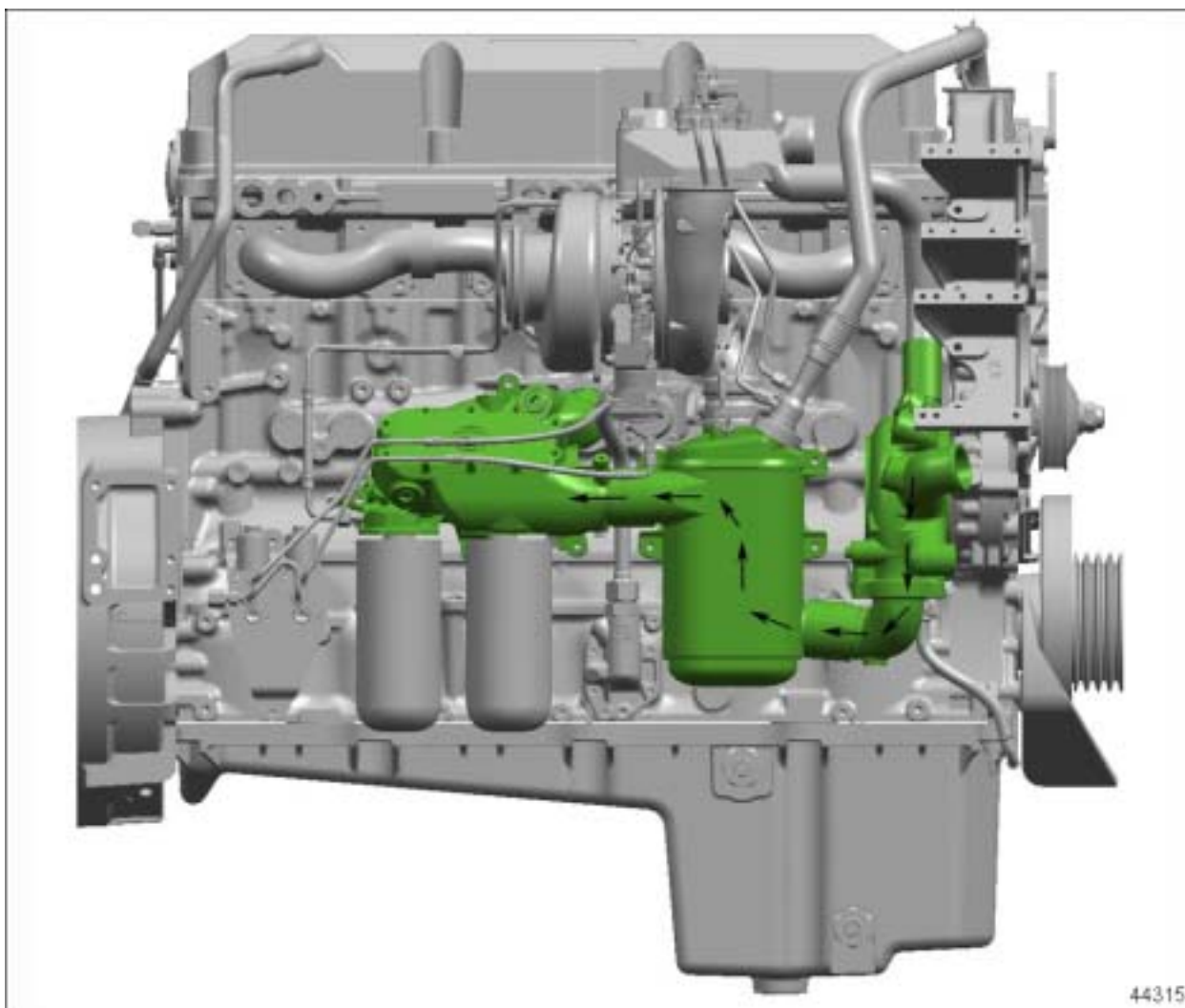

Exhaust gas enters the EGR cooler at high temperatures and is cooled by the engine coolant system to increase the density of the gas. **This graphic illustrates coolant flow.**

## EGR Measurement

### EGR Mode

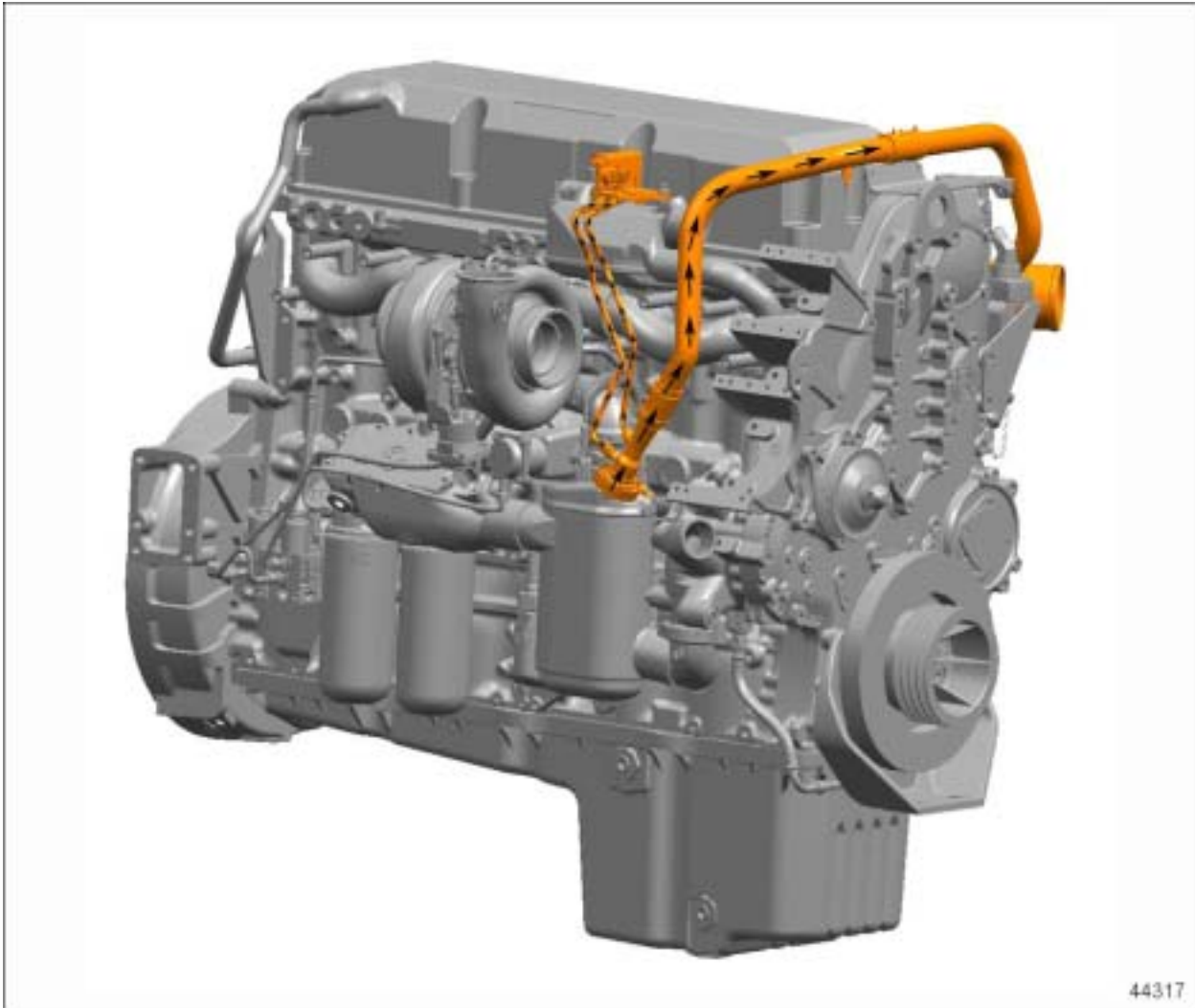

Once EGR begins flow through the EGR cooler and past the venturi, pressure levels are measured from the two venturi taps or ports. The delta pressure measurement, in conjunction with the EGR temperature, determines the EGR flow rate.

## VNT Controls

### EGR Mode (Flow)

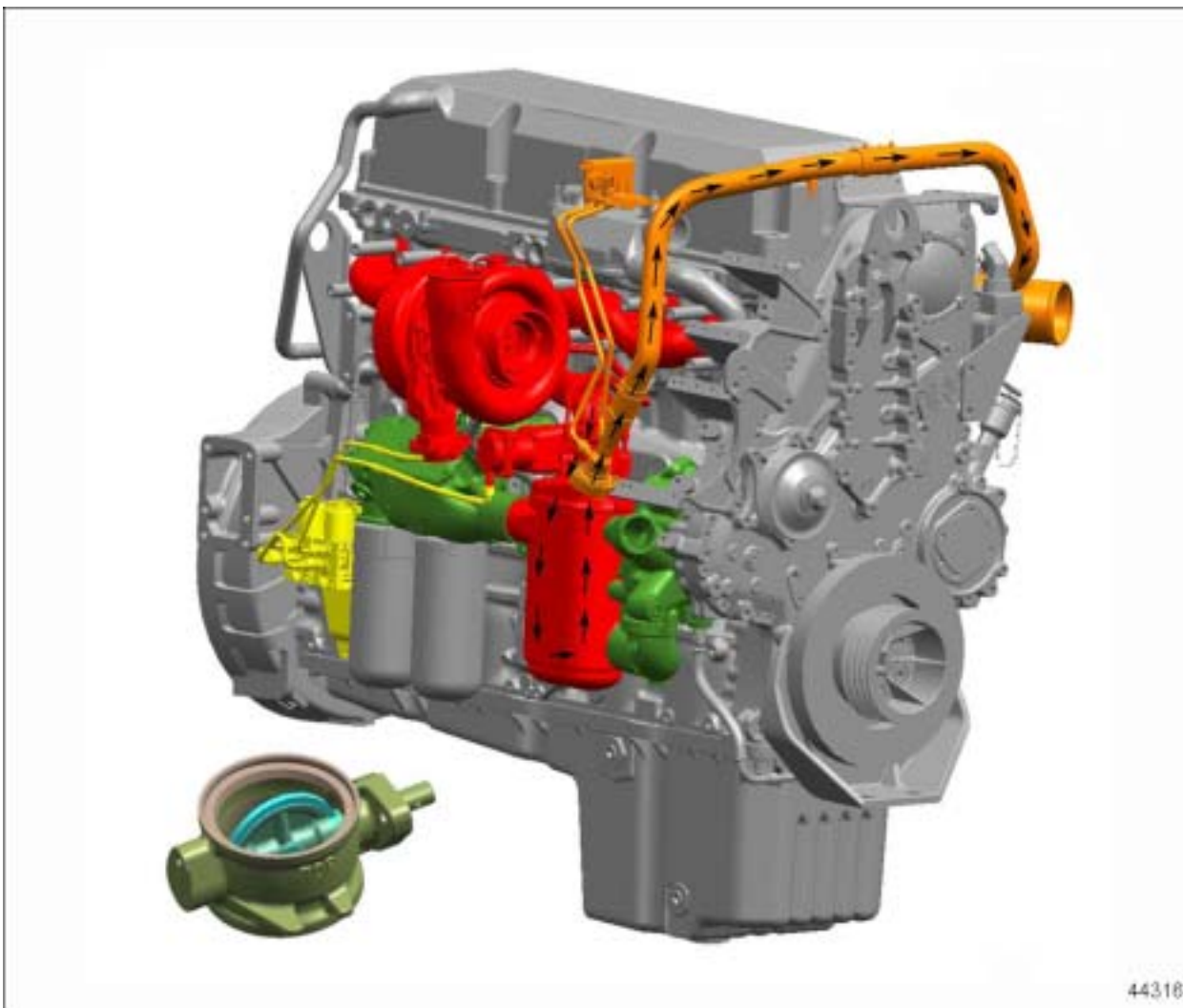

The VNT turbocharger is the mechanism used to change the EGR rate.

The VNT is controlled via the DDEC PWM#4 to regulate air pressure to change the nozzle vane position within the turbocharger.

Changes to the vane position, either closing or opening, result in an increase or decrease to the EGR flow rate.



## 4 CODES

### DIAGNOSTIC TROUBLESHOOTING

This section supports the DDEC IV fault codes recorded during EGR engine operation.

#### Diagnostic Trouble Codes (DTC)

##### Component, Logic, or Engine Protection Codes

Diagnostic trouble codes are generated in the ECM when a condition exists that prevents the engine from operating at peak efficiency. Three primary codes exist Component, Logic, and Engine Protection.

##### Sensor Codes = Yellow

A component DTC is activated when a specific component failure exists. This is most commonly seen as a high volt or low volt code for a specific device. The failure can generally be found within the component or wiring for that component.

##### Engine Protection Codes = Red

An engine protection DTC is activated when a engine operating condition exists that can cause immediate damage to the engine and the engine should be shut down until the condition is corrected to prevent additional damage.

##### Logic Codes = Blue

A logic DTC is activated when specific conditions occur within a given amount of time that the calibration determines is not "normal". For example: If the ECM commands the EGR valve to open or close. The ECM monitors the EGR flow devices for confirmation that flow has begun or ended.

**Logic codes identify a condition NOT a component.**

Example: Code 39 DDEC uses the Differential Pressure sensor and EGR temperature sensor to monitor EGR flow.

If **flow** is detected when there should be no flow, code 39 will activate.

If **NO FLOW** is detected when there should be flow, code 39 will activate.

Conditions that can cause Code 39 include but are not limited to:

- Plugged EGR cooler
- EGR valve defective (stuck open or closed)
- VPOD defective
- Differential pressure sensor plugged

The DTC will help guide the technician to the **condition**. The technician will require a knowledge of the system and proper tools to diagnose the components.



## DDEC IV EGR DESCRIPTIONS

To read codes, use the Detroit Diesel Diagnostic Link (DDDL). The DDDL will display active and inactive fault codes which are listed in Table 4-1.

- Yellow** = Sensor
- Red** = Protection
- Blue** = Logic

DDC Code # (Flashed)	PID	SID	FMI	Description
11	187	-	4	Variable Speed Governor Sensor Voltage Low
12	187	-	3	Variable Speed Governor Sensor Voltage High
13	111	-	4	Coolant Level Sensor Input Voltage Low
14	110	-	3	Coolant Temperature Sensor Input Voltage High
14	175	-	3	Oil Temperature Sensor Input Voltage High
15	110	-	4	Coolant Temperature Sensor Input Voltage Low
15	175	-	4	Oil Temperature Sensor Input Voltage Low
16	111	-	3	Coolant Level Sensor Input Voltage High
17	354	-	3	Relative Humidity Sensor Circuit Failed High
18	354	-	4	Relative Humidity Sensor Circuit Failed Low
21	91	-	3	Throttle Position Sensor Input Voltage High
22	91	-	4	Throttle Position Sensor Input Voltage Low
23	174	-	3	Fuel Temperature Sensor Input Voltage High
24	174	-	4	Fuel Temperature Sensor Input Voltage Low
25	-	-	-	Reserved for "No Codes"
26	-	25	11	Aux. Shutdown #1 Active
26	-	61	11	Aux. Shutdown #2 Active
27	105	-	3	Intake Manifold Temperature Sensor Input Voltage High
27	171	-	3	Ambient Air Temperature Sensor Input Voltage High
28	105	-	4	Intake Manifold Temperature Sensor Input Voltage Low
28	171	-	4	Ambient Air Temperature Sensor Input Voltage Low
29	351	-	4	TCI Temperature Circuit Failed Low
29	404	-	4	TCO Out Sensor Input Voltage Low
31	-	51	3	Aux. Output #3 Open Circuit (High Side) - S3
31	-	51	4	Aux. Output #3 Short To Ground (High Side) - S3
31	-	51	7	Aux. Output #3 Mechanical System Fail - S3
31	-	52	3	Aux. Output #4 Open Circuit (High Side) - T3
31	-	52	4	Aux. Output #4 Short to Ground (High Side) - T3
31	-	52	7	Aux. Output #4 Mechanical System Failure - T3
32	-	238	3	SEL Short to Battery (+)
32	-	238	4	SEL Open Circuit

DDC Code # (Flashed)	PID	SID	FMI	Description
32	-	239	3	CEL Short to Battery (+)
32	-	239	4	CEL Open Circuit
33	102	-	3	Turbo Boost Pressure Sensor Input Voltage High
34	102	-	4	Turbo Boost Pressure Sensor Input Voltage Low
35	100	-	3	Oil Pressure Sensor Input Voltage Low
36	100	-	4	Oil Pressure Sensor Input Voltage Low
37	94	-	3	Fuel Pressure Sensor Input Voltage High
38	94	-	4	Fuel Pressure Sensor Input Voltage Low
39	-	146	2	EGR Leak - Boost Power
39	-	146	12	EGR Leak - Boost Jake
39	-	146	7	EGR Valve Not Responding
39	-	147	2	VNT Vanes Not Responding - Boost Power
39	-	147	11	VNT Vanes at Max - Jake
39	-	147	12	VNT Vanes Not Responding - Boost Jake
39	-	147	14	EGR Flow too Low
39	-	147	7	VNT Vanes Not Responding - EGR
41	-	21	0	Too Many SRS (missing TRS)
42	-	21	1	Too few SRS (missing SRS)
43	111	-	1	Coolant Level Low
44	105	-	0	Intake Manifold Temperature High
44	110	-	0	Coolant Temperature High
44	172	-	0	Air Inlet Temperature High
44	175	-	0	Oil Temperature High
-	105	-	14	Inlet Manifold Temperature Derate
-	110	-	14	Coolant Temperature Derate
45	100	-	1	Oil Pressure Low
46	168	-	1	ECM Battery Voltage Low
46	-	214	1	RTC Backup Battery Voltage Low
46	-	232	1	Sensor Supply Voltage Low
47	102	-	0	Turbo Boost Pressure High
47	106	-	0	Air Inlet Pressure High
48	106	-	1	Air Inlet Pressure Low
48	411	-	1	EGR OPD Low
48	412	-	1	EGR Temperature Low
49	404	-	0	Turbo Compressor Out Temperature High
-	404	-	14	TCO Temperature Derate
51	404	-	3	Turbo Compressor Out Temperature Sensor Input Voltage High
52	-	254	12	A/D Conversion Fail
53	-	253	2	Nonvolatile Checksum Incorrect
53	-	253	12	EEPROM Write Error
53	-	253	13	Out of Calibration

DDC Code # (Flashed)	PID	SID	FMI	Description
54	84	-	12	Vehicle Speed Sensor Fault
55	-	216	14	Other ECM Fault
55	-	231	12	J1939 Data Link Fault
56	-	250	12	J1587 Data Link Fault
57	-	249	12	J1922 Data Link Fault
58	92	-	0	Torque Overload
61	-	xxx	0	Injector xxx Response Time Long
62	-	26	3	Aux. Output #1 Short to Battery (+) - F3
62	-	26	4	Aux. Output #1 Open Circuit - F3
62	-	26	7	Aux. Output #1 Mechanical System Not Responding Properly - F3
62	-	40	3	Aux. Output #2 Short to Battery (+) - A2
62	-	40	4	Aux. Output #2 Open Circuit - A2
62	-	40	7	Aux. Output #2 Mechanical System Not Responding Properly - A2
62	-	53	3	Aux. Output #5 Short to Battery (+) - W3
62	-	53	4	Aux. Output #5 Open Circuit - W3
62	-	53	7	Aux. Output #5 Mechanical System Not Responding Properly - W3
62	-	54	3	Aux. Output #6 Short to Battery (+) - X3
62	-	54	4	Aux. Output #6 Open Circuit - X3
62	-	54	7	Aux. Output #6 Mechanical System Not Responding Properly - X3
62	-	55	3	Aux. Output #7 Short to Battery (+) - Y3
62	-	55	4	Aux. Output #7 Open Circuit - Y3
62	-	55	7	Aux. Output #7 Mechanical System Not Responding Properly - Y3
62	-	56	3	Aux. Output #8 Short to Battery (+) - A1
62	-	56	4	Aux. Output #8 Open Circuit - A1
62	-	56	7	Aux. Output #8 Mechanical System Not Responding Properly - A1
63	-	57	0	PWM #1 Above Normal Range
63	-	57	1	PWM #1 Below Normal Range
63	-	57	3	PWM #1 Short to Battery (+)
63	-	57	4	PWM #1 Open Circuit
63	-	58	0	PWM #2 Above Normal Range
63	-	58	1	PWM #2 Below Normal Range
63	-	58	3	PWM #2 Short to Battery (+)
63	-	58	4	PWM #2 Open Circuit
63	-	59	0	PWM #3 Above Normal Range
63	-	59	1	PWM #3 Below Normal Range
63	-	59	3	PWM #3 Short to Battery (+)
63	-	59	4	PWM #3 Open Circuit
63	-	60	0	PWM #4 Above Normal Range

DDC Code # (Flashed)	PID	SID	FMI	Description
63	-	60	1	PWM #4 Below Normal Range
63	-	60	3	PWM #4 Short to Battery (+)
63	-	60	4	PWM #4 Open Circuit
64	103	-	0	Turbo Overspeed
64	103	-	8	Turbo Speed Sensor Input Failure - Abnormal Period
67	106	-	3	Air Inlet Pressure Sensor Input Voltage High
67	106	-	4	Air Inlet Pressure Sensor Input Voltage Low
68	-	230	5	TPS Idle Validation Circuit Fault (open circuit)
68	-	230	6	TPS Idle Validation Circuit Fault (short to ground)
71	-	xxx	1	Injector xxx Response Time Short
72	84	-	0	Vehicle Overspeed
72	84	-	11	Vehicle Overspeed (Absolute)
73	-	151	14	ESS Transmission Stuck in Gear
73	-	226	11	Transmission Neutral Switch Failure (ESS Transmission)
73	-	227	2	Aux Analog Input Data Erratic, Intermittent, or Incorrect (ESS Transmission)
73	-	227	3	Aux Analog Input #1 Voltage High (ESS Transmission)
73	-	227	4	Aux Analog Input #1 Voltage Low (ESS Transmission)
74	70	-	4	Optimized Idle Safety Loop Short to Ground
74	99	-	0	Oil Filter Restriction High
75	168	-	0	ECM Battery Voltage High
75	-	214	0	RTC Backup Battery Voltage High
75	-	232	0	Sensor Supply Voltage High
76	121	-	0	Engine Overspeed With Engine Brake
77	100	-	0	Engine Oil Pressure High
77	102	-	1	Turbo Boost Pressure Low
77	108	-	0	Barometric Pressure High
77	108	-	1	Barometric Pressure Low
77	174	-	0	Fuel Temperature High
77	354	-	0	Relative Humidity Above Range
77	354	-	1	Relative Humidity Below Range
78	86	-	14	Cruise Control/Adaptive Cruise Control Fault
81	411	—	3	EGR Delta pressure circuit failed high
81	412	—	3	EGR temperature circuit failed high
81	412	—	9	EGR temperature smart sensor not responding
82	-	412	9	EGR Temperature Smart Sensor not Responding
82	-	412	12	EGR Temperature Smart Sensor Failed
82	411	—	4	EGR Delta pressure circuit failed low
82	412	—	4	EGR Temperature circuit failed low

DDC Code # (Flashed)	PID	SID	FMI	Description
83	73	-	0	Pump Pressure High
83	411	-	0	EGR Delta Pressure High
83	412	-	0	EGR Temperature High
85	190	-	0	Engine Overspeed
85	190	-	14	Engine Overspeed Signal
86	73	-	3	Pump Pressure Sensor Input Voltage High
86	108	-	3	Barometric Pressure Sensor Input Voltage High
87	73	-	4	Pump Pressure Sensor Input Voltage Low
87	108	-	4	Barometric Pressure Sensor Input Voltage Low

**Table 4-1 Flash Codes, SAE Codes, Descriptions**

### LOGIC CODES (MECHANICAL FAILURES)

Logic codes indicate the detection of mechanical failures by the DDEC system. The response will be a Flash Code.

#### Diagnosing Flash Code 39

*Failure Mode:* **SID 146, FMI 7 — EGR Valve Not Responding**

*Indicates:* **EGR flow requested by DDEC and no EGR flow detected.**

SID 146, FMI 7 will be set by the ECM if, the signal from the Delta P sensor and EGR temperature sensor indicate EGR flow is below a minimum allowable flow when the ECM is in “EGR Mode” for a period greater than 50 seconds.

*Response:* The CEL will be illuminated and the system will be forced into “Boost Mode” (EGR is Disabled) for the remainder of the ignition cycle.

*Possible Causes:*

- EGR valve mechanical failure (closed)
- Plugged EGR cooler
- Defective Delta P sensor
- Plugged Delta P ports
- VNT vanes stuck in an open position
- Exhaust leaking at the S Pipe
- Exhaust leaking at the EGR valve
- Leaking air lines from the VPOD to the actuators (insufficient air supply)
- Leaking or low vehicle air supply to the VPODs
- VPOD mechanical failure

**Failure Mode: SID 146, FMI 2 — EGR Leak (Boost Mode)**

**Indicates: No EGR flow requested by DDEC and EGR flow detected.**

SID 146, FMI 2 will be set by the ECM if, the signal from the Delta P sensor and EGR temperature sensor indicate EGR flow is above a maximum allowable flow when the ECM is in “Boost Mode” for a period greater than 50 seconds.

*Response:* The CEL will illuminate and a fault message will be generated.

*Possible Causes:*

- EGR valve mechanical failure (open)
- Defective Delta P sensor
- Plugged Delta P lines

**Failure Mode: SID 146, FMI 12 — EGR Leak (Boost Jake)**

**Indicates: No EGR flow requested by DDEC and EGR flow is detected while braking.**

SID 146, FMI 12 will be set by the ECM if, the signal from the Delta P sensor and EGR temperature sensor indicate EGR flow is above a maximum allowable flow when the ECM is in “Jake Mode” for a period greater than 50 seconds.

*Response:* The CEL will illuminate and a fault message will be generated.

*Possible Causes:*

- EGR valve mechanical failure (open)
- Defective Delta P sensor
- Plugged Delta P lines

**Failure Mode: SID 147, FMI 7 — VNT Vanes Not Responding (EGR Mode)**

**Indicates:** EGR flow requested by DDEC and excessive EGR flow detected.

SID 147, FMI 7 will be set by the ECM if, the signal from the Delta P sensor and EGR temperature sensor indicate EGR flow is above a desired flow for a period greater than 50 seconds.

**Response:** The CEL will be illuminated and the system will be forced into “Boost Mode” (EGR is Disabled) for the remainder of the ignition cycle.

**Possible Causes:**

- VNT vanes/actuator — mechanical failure
- High exhaust restriction
- Defective Delta P sensor
- EGR valve — mechanical failure

**Failure Mode: SID 147, FMI 14 — EGR Flow Too Low**

**Indicates:** EGR flow requested by DDEC and insufficient EGR flow detected.

SID 147, FMI 14 will be set by the ECM if, the signal from the Delta P sensor and EGR temperature sensor indicate EGR flow is below a desired flow for a period greater than 50 seconds.

**Response:** The CEL will illuminate and a fault message will be generated.

**Possible Causes:**

- VNT vanes/actuator — mechanical failure
- EGR cooler restriction
- Defective Delta P sensor
- Plugged Delta P ports
- EGR valve mechanical failure
- EGR valve leaks
- VPOD mechanical failure
- Exhaust leaking at the S pipe
- Leaking air lines from the VPOD to the actuators (insufficient air supply)
- Leaking or low vehicle air supply to the VPODs

**Failure Mode: SID147, FMI 2 — VNT Vanes Not Responding (Boost Power)**

**Indicates: Low boost or high boost.**

SID147, FMI 2 will be set by the ECM if, the signal from the manifold pressure sensor indicates “Actual Boost” is above “Desired Boost” OR “Actual Boost” is below “Minimum Boost” when the ECM is in “Boost Mode” for a period greater than 50 seconds.

*Response:* The CEL will illuminate and a fault message will be generated.

*Possible Causes:*

- VNT vanes/actuator mechanical failure
- Turbocharger failure (e.g. damaged or defective compressor/turbine wheel)
- Low vehicle air pressure supply
- Restricted air inlet (including filter)
- Low fuel pressure (e.g. restricted fuel supply)
- Exhaust manifold leakage
- Leaking delivery pipe
- Defective or leaking VPOD
- Leaking air system
  - Charge air cooler
  - Hoses
  - Loose hose clamps



**Failure Mode: SID147, FMI 12 — VNT Vanes Not Responding (Boost Jake)**

**Indicates: Low boost or high boost while braking.**

SID147, FMI 12 will be set by the ECM if, the signal from the manifold pressure sensor indicates “Actual Boost” is above “Desired Boost” OR “Actual Boost” is below “Minimum Boost” when the ECM is in “Jake Mode” for a period greater than 50 seconds.

*Response:* The CEL will illuminate and a fault message will be generated.

*Possible Causes:*

- VNT vanes/actuator mechanical failure
- Turbocharger failure (e.g. damaged or defective compressor/turbine wheel)
- Restricted air inlet (including filter)
- Exhaust manifold leakage
- EGR valve leakage
- Delivery pipe leakage
- Low vehicle air pressure supply
- Defective or leaking VPOD
- Leaking air system
  - Charge air cooler
  - Hoses
  - Loose hose clamps

## Sensor Codes

Specific sensor failures and the system response are listed below:

### Barometric Pressure Sensor

*Failure Modes:* PID 108, FMI 3 - Voltage High and FMI 4 - Voltage Low

*Response:* The CEL will be illuminated and the engine will be forced into boost mode. The turbocharger vane position will be forced open at idle to reduce turbocharger response.

### Turbo Boost Pressure Sensor

*Failure Modes:* PID 102, FMI 3 - Voltage High and FMI 4 - Voltage Low

*Response:* The CEL will be illuminated and the system will be forced into boost mode. The turbocharger vane position will be set to a calibrated value to protect the engine and will be torque limited during this fault.

### Intake Manifold Temperature Sensor

*Failure Modes:* PID 105, FMI 3 - Voltage High and FMI 4 - Voltage Low

*Response:* The CEL will be illuminated and the temperature will be set to a fixed value.

### Turbo Compressor Outlet Temperature Sensor

*Failure Modes:* PID 404, FMI 3 - Voltage High and FMI 4 - Voltage Low

*Response:* The CEL will be illuminated and the engine will be torque limited to protect the turbocharger and charge air cooler.

### EGR Delta-Pressure Sensor

*Failure Modes:* PID 411, FMI 3 - Voltage High and FMI 4 - Voltage Low

*Response:* The CEL will be illuminated and the system will be forced into boost mode. The engine will be torque limited during this fault.

### EGR Temperature Sensor

*Failure Modes:* PID 412, FMI 3 - Voltage High and FMI 4 - Voltage Low

*Response:* The CEL will be illuminated and the temperature will be set to a fixed value.

### Turbo Compressor Inlet Temperature Sensor

*Failure Modes:* PID 351, FMI 3 - Voltage High and FMI 4 - Voltage Low

*Response:* The CEL will be illuminated and the temperature will be set to a fixed value.

### Relative Humidity Sensor

*Failure Modes:* PID 354, FMI 3 - Voltage High and FMI 4 - Voltage Low

*Response:* The CEL will be illuminated and the sensor will be set to a fixed value.

### Coolant Temperature Sensor

*Failure Modes:* PID 110, FMI 3 - Voltage High and FMI 4 - Voltage Low

*Response:* The CEL will be illuminated and the temperature will be set to a fixed value.

### Turbo Speed Sensor

*Failure Modes:* PID 103, FMI 8 - Abnormal Period

*Response:* The CEL will be illuminated and the system will be forced into boost mode. The VNT vane position will be restricted so the vane will not close beyond a calibrated position. The engine will be torque limited during this fault.

### Ambient Air Temperature Sensor

*Failure Modes:* PID 171, FMI 3 - Voltage High and FMI 4 - Voltage Low

*Response:* The CEL will be illuminated and the temperature will be set to a calibrated value.

## Protection Codes

### Engine Protection Codes

When these codes are logged and turn on both the check engine and stop engine lights. This alerts the operator that continued engine operation under those conditions will result in engine damage.

### Coolant Temperature High

PID 110 FMI 0 indicates the coolant temperature has risen above the programmed value in the ECM. The temperature limits are listed in Table 4-2.

### Oil Pressure Low

PID 100 FMI 1 indicates that the oil pressure has dropped below a programmed value of 30 seconds. Both CEL and SEL will illuminate.

The Series 60 pressure limit parameters and listed below. See Figure 4-1.

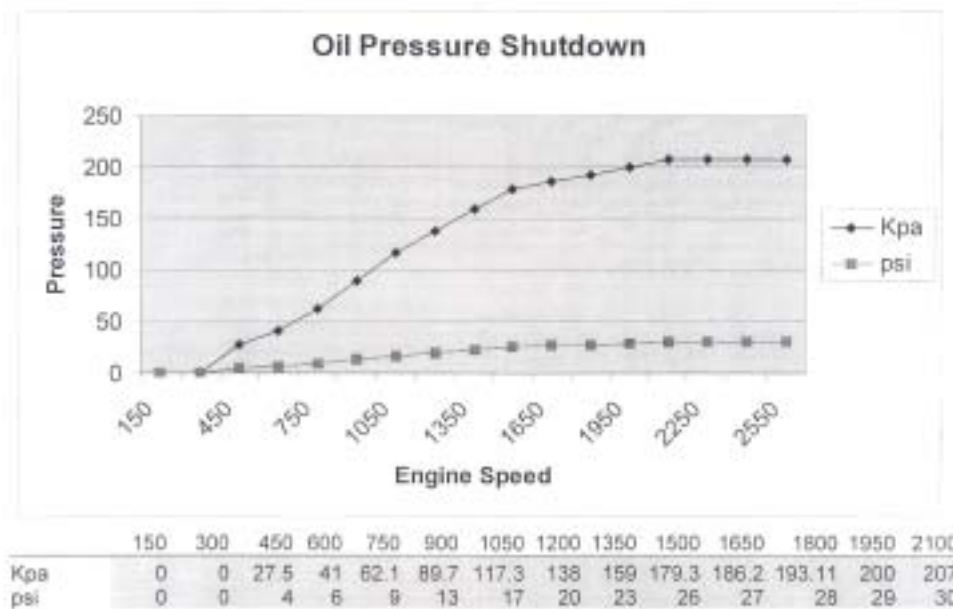

44244

**Figure 4-1 Oil Pressure Shutdown**

**Coolant Level Low**

PID 111 FMI 1

When the coolant level has fallen below the Coolant Level Sensor for 30 seconds, the CEL and SEL will illuminate.

**Oil Temperature High**

PID 175 FMI 0 indicates that the oil temperature has risen above the programmed value in the ECM. The CEL will illuminate at 239° F (115° C) and the SEL will illuminate at 250° F (121° C).

Listed in Table 4-2 are the vehicle performance temperature limits.

Year	Start Derate	EGR Off	CEL	SEL
<b>Coolant Temperature</b>				
2002	214° F (101° C)	221° F (105° C)	223° F (106° C)	225° F (107° C)
2004	219° F (103° C)	228° F (108° C)	227° F (108° C)	229° F (109° C)
<b>Compressor Discharge Temperature at Sea Level</b>				
2002	453° F (223° C)	—	554° F (290° C)	—
2004	445° F (229° C)	—	515° F (268° C)	—
<b>Intake Manifold Temperature</b>				
2002	201° F (93° C)	213° F (100° C)	218° F (103° C)	—
2004	203° F (95° C)	216° F (102° C)	212° F (100° C)	—
<b>Oil Temperature</b>				
2002	239° F (115° C)	—	239° F (115° C)	250° F (121° C)
2004	243° F (117° C)	—	244° F (117° C)	253° F (122° C)

**Table 4-2 Temperature Limits**

## 5 DDEC IV TESTING

The following pages identify a logical troubleshooting flow for specific operational concerns. The complaints and diagnostics are based on conditions identified by DDC Technical Service. Information in this publication is accurate as of March 2004.

### Troubleshooting Task

- Intermittent Black Smoke . Page 5-2.
- Power Loss Under Heavy Pull . Page 5-3.
- Low Boost Under Cold Ambient Conditions . Page 5-4.
- Derate Codes 110 and 404 FMI 14 . Page 5-4.
- Code 39 . Page 5-4.
- Exhaust Smell/Fumes . Page 5-5.
- Slobbering . Page 5-5.
- Engine Vibration . Page 5-5.
- Engine Coolant Loss . Page 5-6.
- Engine Backfire, Engine Misfire, Intermittent Exhaust Smoke . Page 5-6.

### Testing Procedures

- Test A . Page 5-7.
- Test B . Page 5-8.
- Exhaust Gas Recirculation System Basic Checks . Page 5-9.

## Intermittent Black Smoke

Perform the following steps for **Intermittent Black Smoke**.

1. Check for diagnostic trouble codes.
  - [a] If Fault Codes are logged, diagnose the logged codes first.
2. Visually inspect the air filter restrictions.
  - [a] If the air filter is clogged or dirty, replace the air filter.
3. Visually inspect the air inlet hoses for soft or collapsed areas.
  - [a] If the air inlet hoses are damaged, replace as necessary.
4. Visually inspect the air inlet for restrictions.
  - [a] If the air inlet has restrictions, clean as necessary.
5. Perform *Test A* . Page 5–7.
6. Perform *Exhaust Gas Recirculation System Basic Checks* . Page 5–9.
7. Test drive the vehicle with DDDL and perform a snapshot. Analyze the snapshot.
8. Perform *Test B* . Page 5–8.

## Power Loss Under Heavy Pull

In extreme cold ambient conditions, the engine will operate in **Condensation Protection**. During this mode of operation, the engine **boost** will be reduced and there is no reduction of power. Operating in this mode is a normal operating condition and will not affect engine life or performance. **Note:** Trucks operating with winter fronts will experience this condition less often. DDC's recommendations have not changed regarding winterfront usage. A service bulletin issued years ago will be re issued to restate DDC's position.

Perform the following steps for **Power Loss Under Heavy Pull**.

1. Check for diagnostic trouble codes.
  - [a] If Fault Codes are logged, diagnose the logged codes first.
2. Visually inspect the air filter restrictions.
  - [a] If the air filter is clogged or dirty, replace the air filter.
3. Visually inspect the air inlet hoses for soft or collapsed areas.
  - [a] If the air inlet hoses are damaged, replace as necessary.
4. Visually inspect the air inlet for restrictions.
  - [a] If the air inlet has restrictions, clean as necessary.
5. Visually inspect the entire length of the breather tube for kinks.
  - [a] If the breather tube has kinks, repair as necessary.
6. Measure the fuel pressure under heavy loads.
  - [a] If the fuel pressure was spiking or decreasing, perform step 7.
  - [b] If the fuel pressure was not spiking or decreasing, testing is complete.
7. Remove the fuel pump.
  - [a] If the fuel pump is damaged, replace the fuel pump.
  - [b] If the fuel pump is not damaged, perform step 8.
8. Remove the fuel injectors and inspect for combustion passing the seat.
  - [a] If seats are damaged, replace as necessary.

### **NOTE:**

The injector may need to be replaced also.

- [b] If the seats are not damaged, testing is complete.

## Low Boost Under Cold Ambient Conditions

In extreme cold ambient conditions, the engine will operate in **Condensation Protection**. During this mode of operation, the engine **boost** will be reduced and there is no reduction of power. Operating in this mode is a normal operating condition and will not affect engine life or performance. **Note:** Trucks operating with winter fronts will experience this condition less often. DDC's recommendations have not changed regarding winterfront usage. A service bulletin issued years ago will be re issued to restate DDC's position.

Perform the following step for Low Boost Under Cold Ambient Conditions.

1. Clear Fault Codes and return the engine to service.

## Derate Codes 110 and 404 FMI 14

Perform the following steps for **Derate Codes 110 and 404 FMI 14**.

1. Determine if derate is typical operation (refer to Appendix D, *Service Information Letter* 03 TS-23).

### NOTE:

During **Typical** engine operating conditions, the engine will derate to prevent damage. Higher ambient temperatures and loads will increase the frequency of DDEC applying this derate logic. If the derate is occurring only occasionally, this is **Typical**. If the derate occurs more than **Typical** for given operating conditions, continue investigation for possible defects.

- [a] If considered **Typical**, clear Fault Codes and return the engine to service.
  - [b] If determined to be abnormal frequency, perform step 2.
2. Remove the water pump and inspect the pump impeller.
    - [a] If the impeller is damaged, replace the water pump.
    - [b] If the impeller is not damaged, reuse the water pump and replace the EGR cooler.

## Code 39

Perform the following steps for **Code 39**.

1. Perform *Exhaust Gas Recirculation System Basic Checks* . Page 5–9.
2. Perform *Test A* . Page 5–7.
3. Test drive the vehicle with DDDL and perform a snapshot. Analyze the snapshot.
4. Inspect the VPOD air supply for leaks.
  - [a] If the VPOD air supply has leaks, repair the leak.
5. Perform *Test B* . Page 5–8.



## Exhaust Smell/Fumes

Perform the following steps for **Exhaust Smell/Fumes**.

1. Visually inspect the exhaust system for leaks (e.g. exhaust manifold, S-pipe, and turbocharger).
  - [a] If exhaust leaks were detected, repair as necessary.
  - [b] If no exhaust leaks were detected, perform step 2.
2. Tighten all S-pipe clamps to the proper torque specification.
3. Reprogram the ECM.

## Slobbering

Perform the following steps for **Slobbering**.

1. Visually inspect the entire length of the breather tube for kinks.
  - [a] If the breather tube is damaged, repair as necessary.
  - [b] If the breather tube is not damaged, perform step 2.
2. Perform a DDC Extraction of DDEC Reports.

### NOTE:

Review extraction for excessive idle time. Times of 35% and higher are considered excessive.

3. Drain the engine lubrication oil pan.
4. Refill the lubrication oil pan with 32 quarts of approved motor oil and visually inspect the oil dipstick marking.
  - [a] If the oil dipstick marking is incorrect, replace the dipstick with a proper dipstick.
  - [b] If the oil dipstick marking was correct, testing is complete.

## Engine Vibration

Perform the following steps for **Engine Vibration**.

1. Using a 0.060 in. feeler gage, measure the clearance between the bottom of the steel engine mount and the rubber biscuit at the rear engine chassis mounts.
  - [a] If the engine mount clearance is less than 0.060 in., replace the mount.
  - [b] If the engine mount clearance is greater than 0.060 in., testing is complete.

## Engine Coolant Loss

Perform the following steps for **Engine Coolant Loss**.

1. Verify the quantity of engine coolant loss per mile.

**NOTE:**

\_\_\_\_\_ Miles driven \_\_\_\_\_ Coolant added

 <b>WARNING:</b>
<b>PRESSURIZED AIR AND FLYING PARTICLES</b>
<b>To avoid injury to eye or face, wear a face shield or goggles when conducting a pressure test.</b>

2. Pressure test the cooling system.
3. Visually inspect the engine for external coolant leaks (e.g. water pump, coolant hoses, etc.).
  - [a] If coolant leaks were detected, replace the leaking component as required.
  - [b] If no coolant leaks were detected, perform step 4.
4. Visually inspect the engine oil for coolant.
  - [a] Coolant is found in the engine oil, this indicates an oil cooler or internal engine fault.
  - [b] If no coolant is found, perform step 4[c].
  - [c] If the engine is losing coolant at a rate of more than 1 gallon in 5000 miles, and no engine coolant leaks were detected, replace the EGR cooler.
  - [d] If the engine is losing coolant at a rate of less than 1 gallon in 5000 miles, contact the Detroit Diesel Technical Service Group.

## Engine Backfire, Engine Misfire, Intermittent Exhaust Smoke

Perform the following steps for **Engine Backfire, Engine Misfire, and Intermittent Exhaust Smoke**.

1. Reprogram the ECM.

## TESTING PROCEDURES

### NOTE:

If further repair, removal, and DDDL procedures are required when performing the testing procedures, please refer to the *Series 60 Service Manual, (6SE483)* or contact the EDS Support Line for DDDL specific questions.

### Test A

Perform Test A as follows:

1. Remove the turbocharger to charge-air-cooler (CAC) pipe.



### WARNING:

#### PRESSURIZED CHARGE COOLER SYSTEM

To avoid eye or face injury from flying debris, wear a face shield or goggles.

2. Pressurize the CAC inlet to 30 psi using special tool TLZ00100 or equivalent tool.
3. Monitor the boost psi using DDDL.
  - [a] If the pressure is below 27 psi, visually inspect the CAC, hoses, and the delivery tube for leaks.
  - [b] If the pressure is at 27 psi or higher, continue to step 4.
4. Activate EGR VPOD (PWM 2) using the DDDL.
5. Monitor the boost psi pressure for pressure drops when the EGR valve opens.

### NOTE:

The pressure should have dropped significantly to approximately 9 psi.

- [a] If the air pressure dropped to 9 psi, no further testing is required and Test A has been completed.
  - [b] If the pressure only dropped slightly, perform step 1 through step 3.
1. Physically inspect the EGR valve for a mechanical failure. If the EGR valve is not functioning correctly, replace the EGR valve.
  2. Visually inspect the EGR cooler for restrictions. If the EGR cooler is restricted, replace the EGR cooler.
  3. Visually check the delivery pipe for restrictions. Clean as necessary to remove restrictions.

## Test B

Perform Test B as follows:

 <b>WARNING:</b> <b>PERSONAL INJURY</b>
<b>Diesel engine exhaust and some of its constituents are known to the State of California to cause cancer, birth defects, and other reproductive harm.</b>
<input type="checkbox"/> <b>Always start and operate an engine in a well ventilated area.</b>
<input type="checkbox"/> <b>If operating an engine in an enclosed area, vent the exhaust to the outside.</b>
<input type="checkbox"/> <b>Do not modify or tamper with the exhaust system or emission control system.</b>

1. Run the engine on a dynamometer to get the engine hot. If a dynamometer is not available, run the engine until hot ( $> 170^{\circ}$  F ( $76^{\circ}$  C) coolant temperature).
2. Activate the VPOD outputs to 90% and back to 7% using the DDDL. Visually inspect the VNT and EGR valve for proper rod travel (full travel to stops).
  - [a] If the VNT is not functioning properly, verify VNT vanes are moving freely (read *Service Information Letter 03 TS 44* located in Appendix D).
  - [b] If the EGR valve is not functioning properly, replace the EGR valve.
  - [c] If both the VNT and EGR valve have proper movement, the test is complete.

### NOTE:

Repeat this step three times.

## Exhaust Gas Recirculation System Basic Checks

Perform the following basic steps to check the exhaust gas recirculating system.

For all EGR related concerns (may include exhaust smoke complaints), perform the following steps. If any corrections are made as a result of these checks, test the unit again before proceeding further:

Basic checks for all Series 60 EGR engines require the following tools:

- 1,000 Ohm resistor (low watt)
- DDR suite 8 or DDDL version 4.2 or higher
- Volt Ohm Meter
- Pressure gage 0–200 psi
- Pressure gage 0–100 psi

### Check Delta P Sensor

Follow these steps to check the Delta-P sensor:

1. Turn ignition ON.
2. Plug in DDR/DDDL.
3. Read Delta-P counts (EGR DPS)
  - [a] If Delta-P counts read 86–135, verify that the EGR pipes and hoses are correctly assembled from the EGR tube to the Delta-P sensor. Reversed hoses or pipes will create black smoke and surging. Go to step 3[b].
  - [b] Also inspect carefully for split or leaking pipes or hoses in the EGR mixer tube from the EGR cooler to the intake manifold. If hoses/pipes are correct, *Check VPOD Output Pressure.*
  - [c] If counts do not fall within the 86–135 range, replace Delta-P sensor; then go to Test.

## Check VPOD Output Pressure



Follow these steps to check both VPOD (EGR valve and VNT) output pressure:

### NOTE:

Listen for air leaks at the VPOD during the test.

### WARNING:

#### PERSONAL INJURY

**To avoid injury from the sudden release of a high-pressure hose connection, wear a face shield or goggles.**

1. Disconnect the air hoses from the EGR and VNT (Variable Nozzle Turbine) actuators.
2. Install pressure gauges (accurate to within 1.4 kPa [0.2 psi]) at the outlet of the EGR and VNT hoses. (Use two gauges, or test separately.)
3. Using the DDR/DDDL, activate PWM #2 (EGR) and PWM #4 (VNT) duty cycles and monitor the output pressure from the VPOD.
4. Test: activating 11 % duty cycle: Pressure = 106 – 134 kPa (15.4 – 19.4 psi). Go to steps 5[a] and 5[b].
5. Test: activating 90 % duty cycle: Pressure = 485 — 515 kPa (70 – 75 psi).
  - [a] If the VPOD readings are as listed, *Check for Active Codes.*

- [b] If the results in this step cannot be attained, *Check VPOD Input Pressure*.

**NOTE:**

Both activations must operate their component with full travel of the linkage to hit the stops.

**Check VPOD Input Pressure**

Follow these steps to check VPOD input pressure:

1. Measure VPOD input pressure to port 1; ensure it is between 703 – 1296 kPa (90 – 120 psi).
  - [a] If the supply pressure is not between 703 – 1296 kPa (90 – 120 psi), troubleshoot the vehicle air system until that result is obtained.
  - [b] If the supply pressure is between 703 – 1296 kPa (90 – 120 psi), *Check Variable Output Pressure Device (VPOD) P/N and Supply Voltage*.

**Check Variable Output Pressure Device (VPOD) P/N and Supply Voltage**

The following checks should be performed for the VPOD P/N and supply voltage:

1. Check VPOD label to determine if it is + 12V or + 24V compatible.
2. Unplug VPODs mating connector. A 1,000 Ohm resistor is needed for the next step. Insert the resistor between cavity 1 and 3 for ease of checking with the VOM.
  - [a] Turn ignition switch ON.
  - [b] Measure voltage from pin 3 to pin 1.
  - [c] Plug in DDR and check ECM voltage.
3. Is the VPOD P/N and voltage, and ECM voltage correct?
  - [a] If the VPOD P/N and voltage are correct, *Check VPOD Wiring..*

## Check VPOD Wiring

The following checks should be performed for the VPOD wiring.

### NOTE:

VPOD power should have been verified under the P/N check. If not, refer to *Check Variable Output Pressure Device (VPOD) P/N and Supply Voltage..*

1. Turn ignition switch ON.
2. Unplug the VPOD mating connector.
3. Insert a 1,000 ohm resistor between cavities #2 and #1 for the 12V version, or cavities #2 and #3 for the 24V version.
4. Connect a VOM to the VPOD connector between pin #2 and pin #3 for the 12V VPOD or pin #2 and pin #1 for the 24V VPOD.
5. Using a DDR/DDDL, activate the PWM #2 (EGR Valve) and PWM #4 (VNT), and ensure:
  - [a] Activating 11 % duty cycle:  $VDC = 90\%$  of the VPOD supply voltage  $\pm 1$  volt (e.g. voltage to VPOD =  $13.8V * 0.9 = 12.42V$ ; therefore 11.42V to 13.42V at PWM is okay.)
  - [b] Activating 90 % duty cycle:  $VDC = 10\%$  of the VPOD supply voltage  $\pm 1$  volt. (e.g. voltage to VPOD =  $13.8V * 0.1 = 1.38V$ , therefore 0.38V to 2.38V at PWM is okay.)
6. Note any air leakage when PWMs are activated to 90% and correct the leaks as needed.
  - [a] If both of the PWM voltage measurements are correct, replace the VPOD that had the wrong pressure reading.
  - [b] If the PWM voltage measurements are incorrect, and the wiring checks are okay, try a test ECM programmed for EGR, or contact DDC Technical Service.



## Check for Active Codes

Check for active codes as follows:

1. Turn ignition ON.
2. Plug in DDR/DDDL.
3. Read active codes.
4. Record or print codes. Ensure that PID, SID, and FMI are recorded. Refer to the proper code section of the *DDEC III/IV Single ECM Troubleshooting Guide*, (6SE497) to troubleshoot that code.

### NOTE:

FMIs listed as 14 are diagnostic information codes and no troubleshooting is required. For example, an engine derates due to high TCO temperature; a 404/14 code will be stored. This would indicate that conditions warranted having the ECM derate the fueling to the engine. If the customer complaint was a power loss, it could be explained that loss of power was done by the ECM to protect other engine components.

5. If the issue is not related to the EGR system components, or assistance is needed, contact Detroit Diesel Technical Service.

## Test

Follow these steps to test:

1. Reassemble connectors or components.
2. Start and run the engine.
3. Perform a road test if this is necessary to duplicate original complaint.
  - [a] If symptoms/codes are gone, repairs are complete.
  - [b] If any codes display, review this section again; contact Detroit Diesel Technical Service.



## 6 DDDL/SNAPSHOTS

### WORKING WITH DDDL SNAPSHOTS

#### Creating A Snapshot

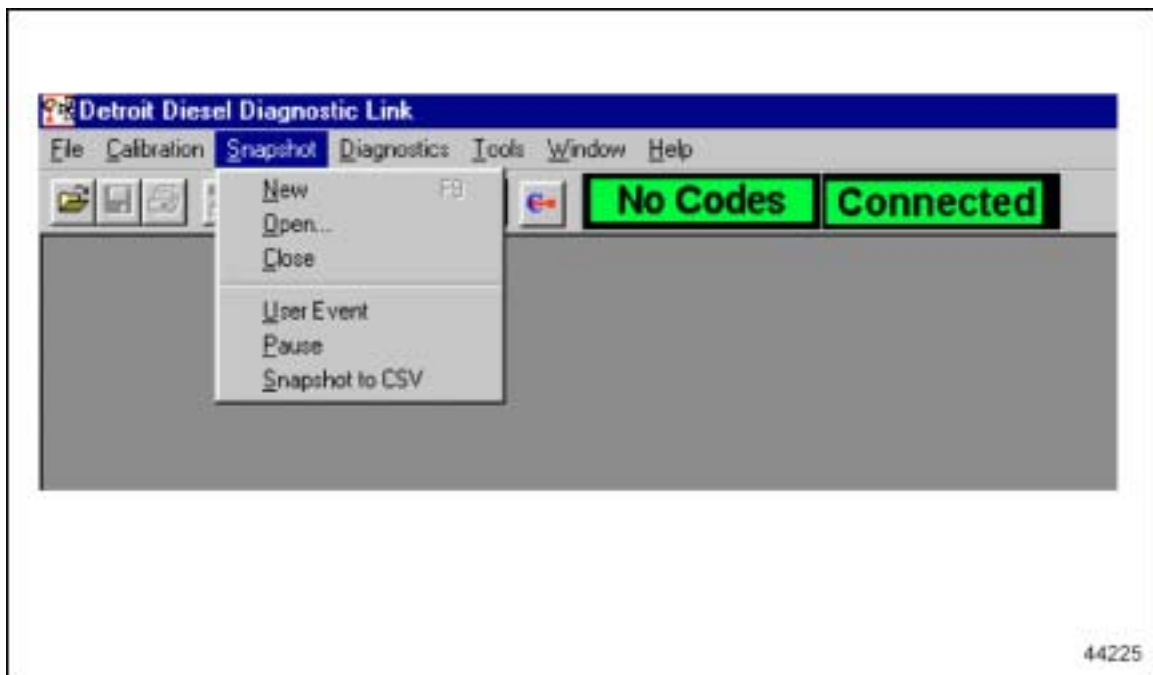

1. Use the proper steps to open DDDL and connect to the engine.
2. Go to the **Snapshot** drop-down menu and select the **New** option by clicking once with the left mouse button.
3. Upon choosing the **New** option a **Record Snapshot** box will appear in the upper left section of your screen.
4. The **Record Time** will be counting from the second you clicked on the **New** option.

5. Some important facts to remember about this feature:
  - All parameters broadcast by DDEC IV are recorded.
  - Any codes that occur during the snapshot are automatically marked.
  - There is no practical time limit for the snapshot, you just need enough room on your hard drive to save the file.
  - To mark an event other than a code, click once with the left mouse button on the **Mark User Event SPACE** box.
  - To insert additional comments about the snapshot click once with the left mouse button on the **Annotate** selection (version 4.1 or later).
6. When you have completed recording the data you wish to save, click once with the left mouse button on the **Stop Recording ESC** box.

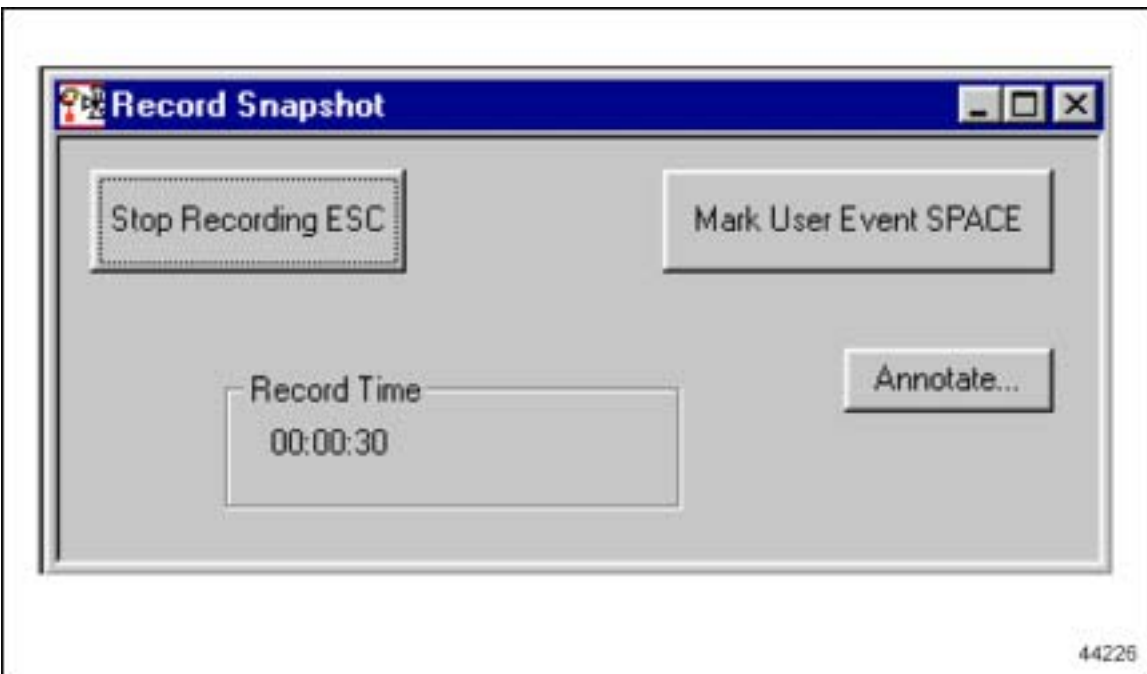

7. Immediately upon selecting the **Stop Recording ESC** option a dialog box will appear asking if you wish to save your changes. If you want to save the recorded data to your hard drive, click once with the left mouse button on the **Yes** option. To discard the data recorded by the snapshot click on the **NO** option.

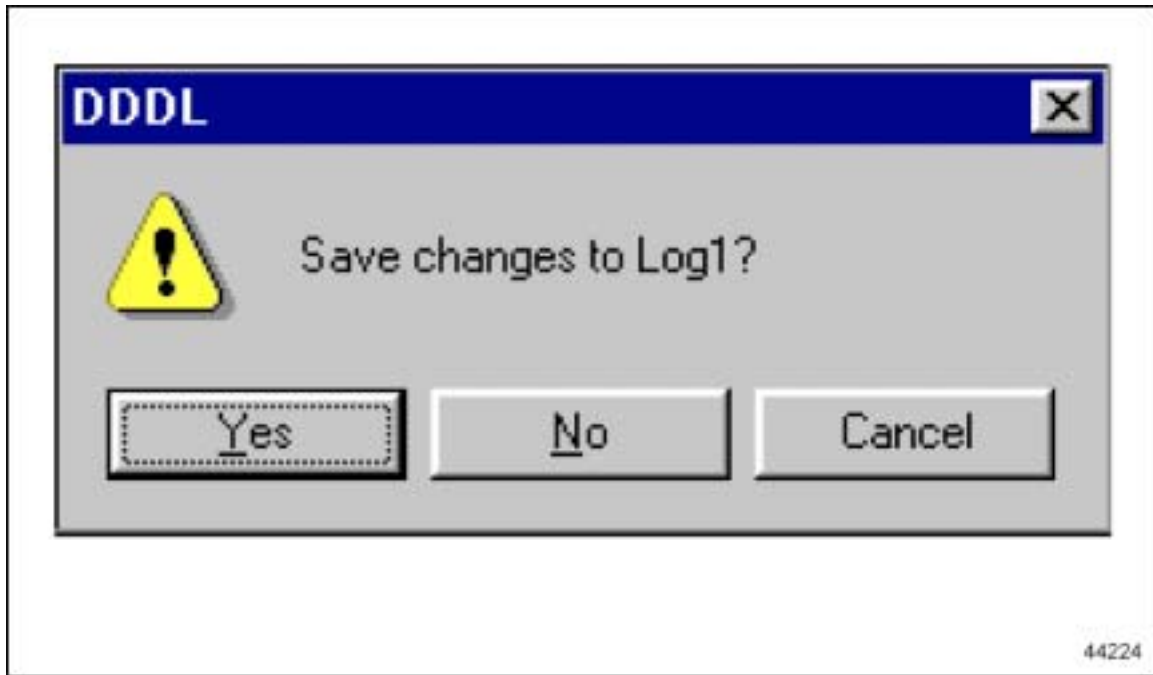

8. If you choose the **Yes** option the **Save As** dialog box will appear on your screen. A suggested file name will appear outlined in blue in the **File Name** box.

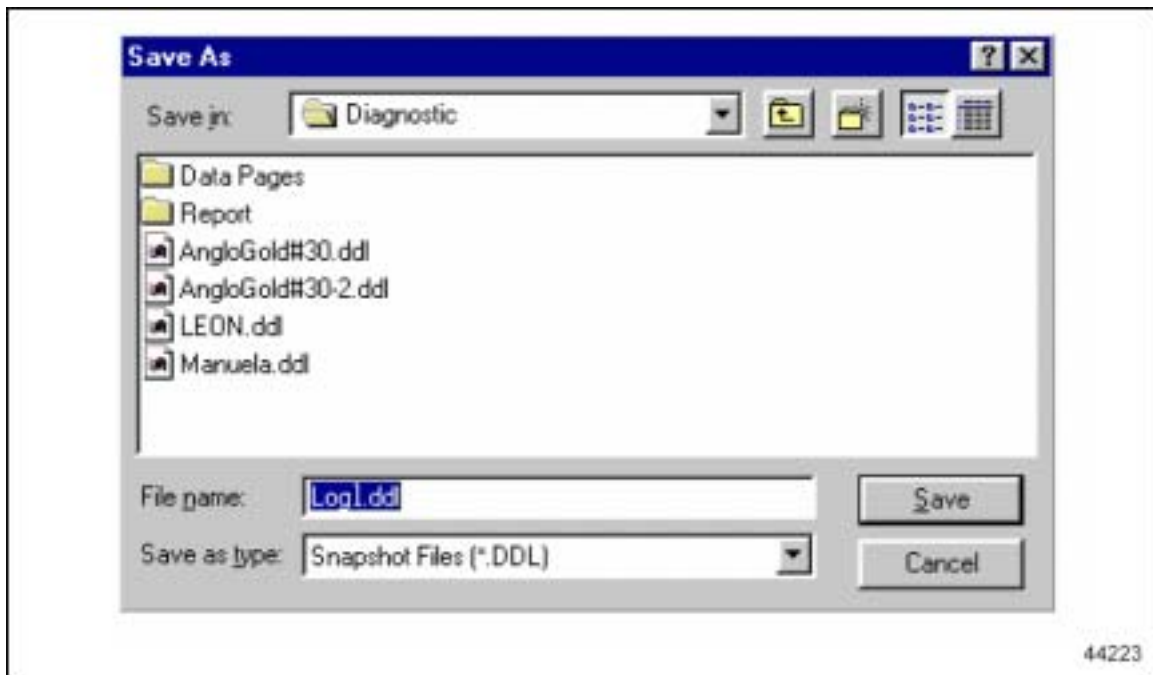

9. If you want to accept the suggested name for the file click once with the left mouse button on the **Save** option box. You may replace the suggested name by hitting the space bar once to clear the line. Type in the new file name before saving the file. You may also change the location of where the file is saved on your PC by changing the location designated in the **Save In** box. You may save the file to your **A** drive for example. Once the file has been saved the process is complete.

## USING SNAPSHOT REPLAY CONTROLS

1. To replay a snapshot, go to the **Snapshot** drop-down menu and select **Open**. You should not be connected to a vehicle when replaying a snapshot.

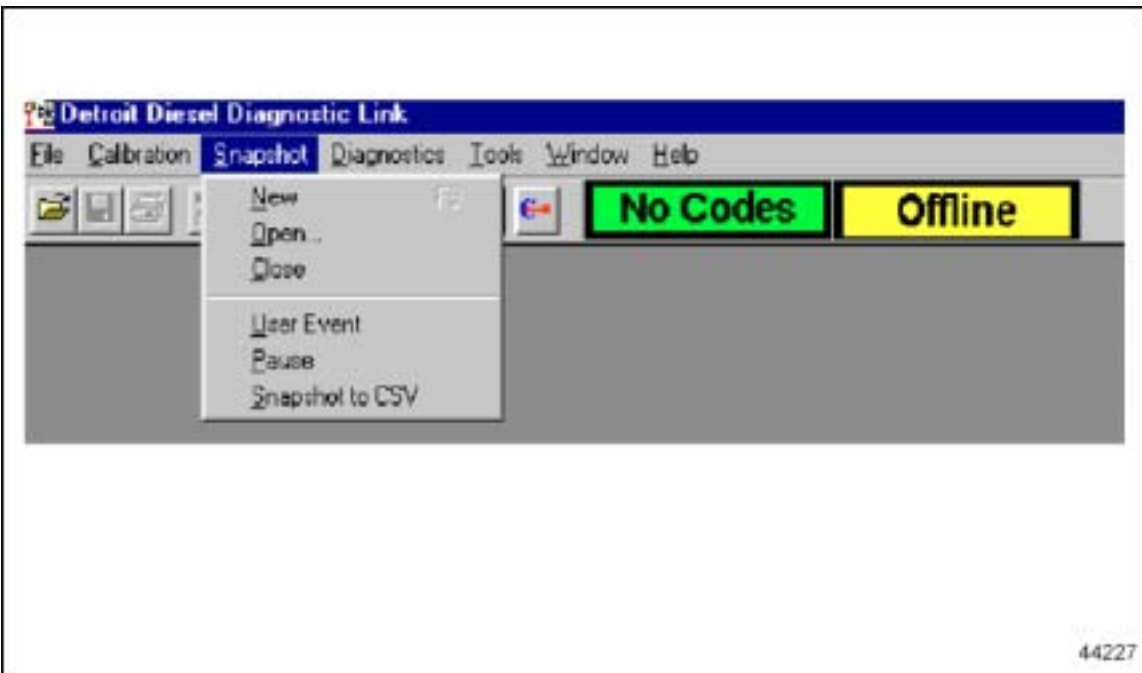

2. A dialog box will appear listing all the available snapshot files.

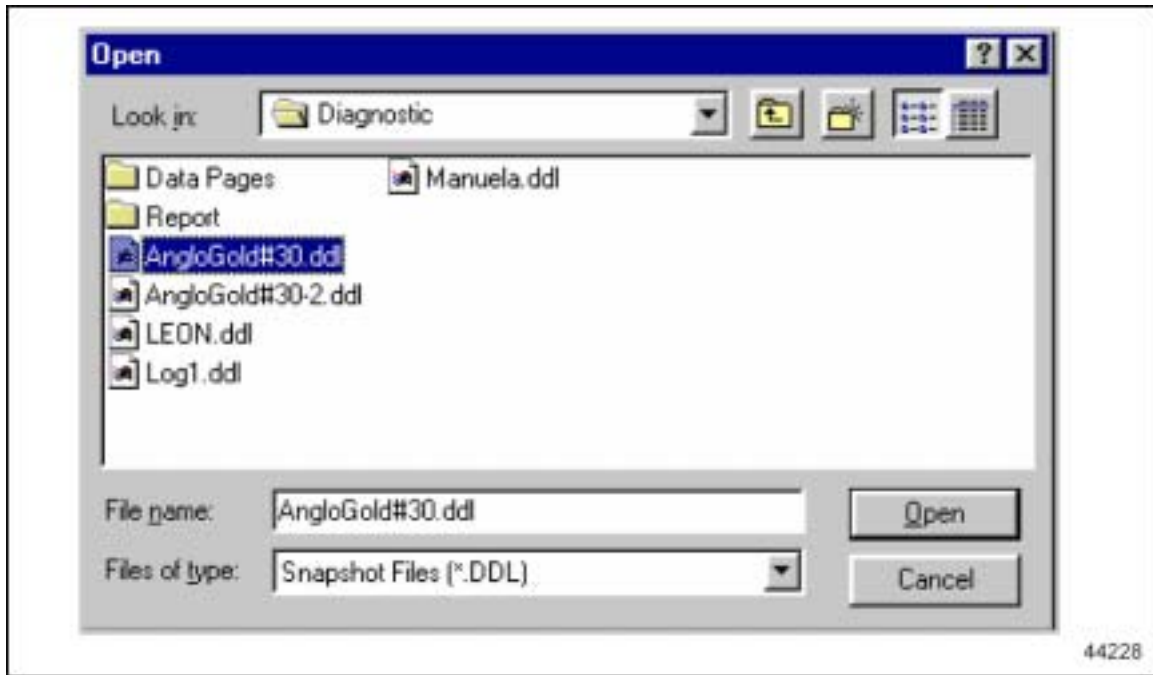
**NOTE:**

The default folder that snapshot files are saved in is C:\Detroit Diesel\Diagnostic and have a file extension of .ddl.

3. Highlight the file you wish to open with one click of the left mouse button. The selected file name will now appear in the **File Name** box.
4. Click once with the left mouse button on the **Open** box in the lower right of the dialog box.
5. When you have opened a snapshot, replay controls will appear at the bottom of the DDDL window you opened.

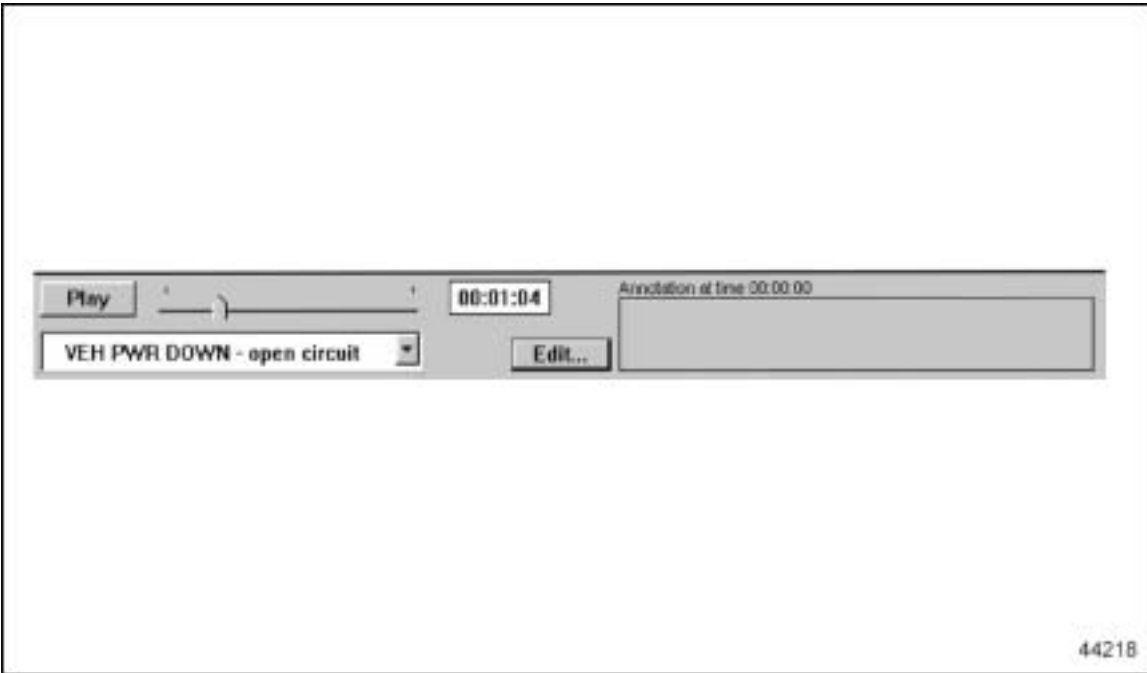

6. Start the replay of a snapshot by clicking on **Play**. The play button changes to **Pause** when a snapshot is replaying. While the snapshot is replaying, the replay slider next to the Play/Pause button moves showing the progress of the replay, and the time box next to it shows the time since the beginning of the recording. When you click on **Play** the snapshot begins to play from its current position and the instruments show the appropriate readings. The event window also changes during the replay to show the most recent event.
7. Stop the replay at a particular point of interest by clicking on **Pause**. The instruments will show the values at the time the replay was stopped.
8. Move to a specific time in the replay by dragging the replay slider button. As you drag the slider, the time shown in the time box changes to reflect the position of the slider.



**NOTE:**

Not all DDDL windows can be activated when replaying the snapshot feature. You cannot access the injector response time window or the cylinder cutout window in snapshot mode. Samples of windows that may be activated include:

**Normal Instrumentation Window**

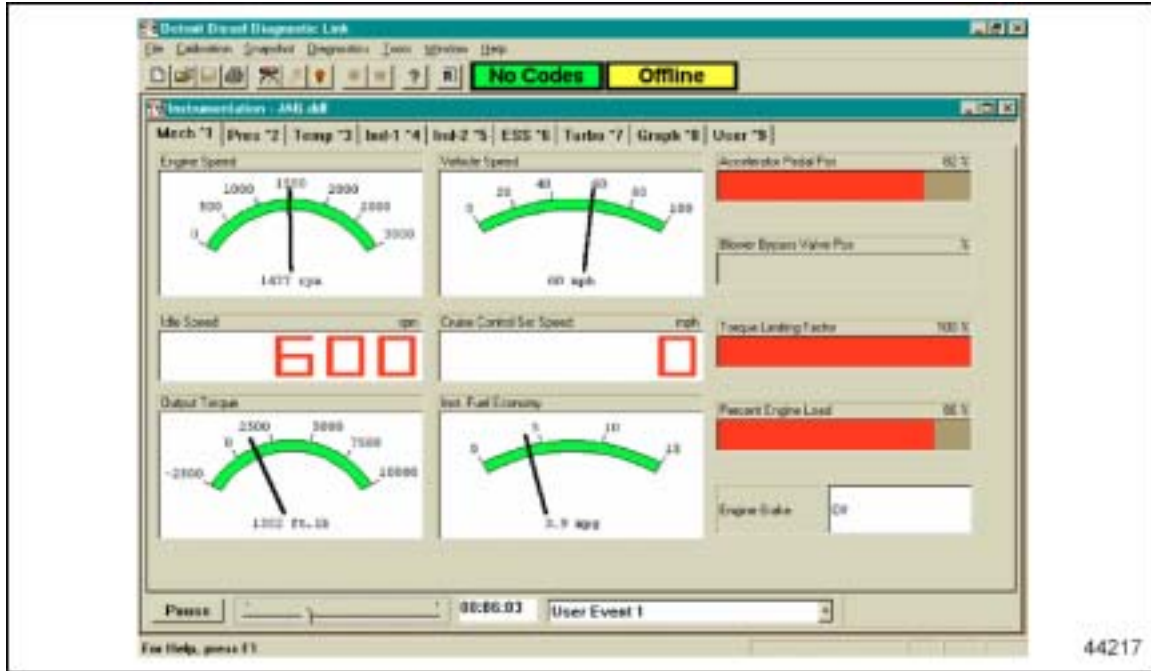

**Diagnostic Instrumentation Window**

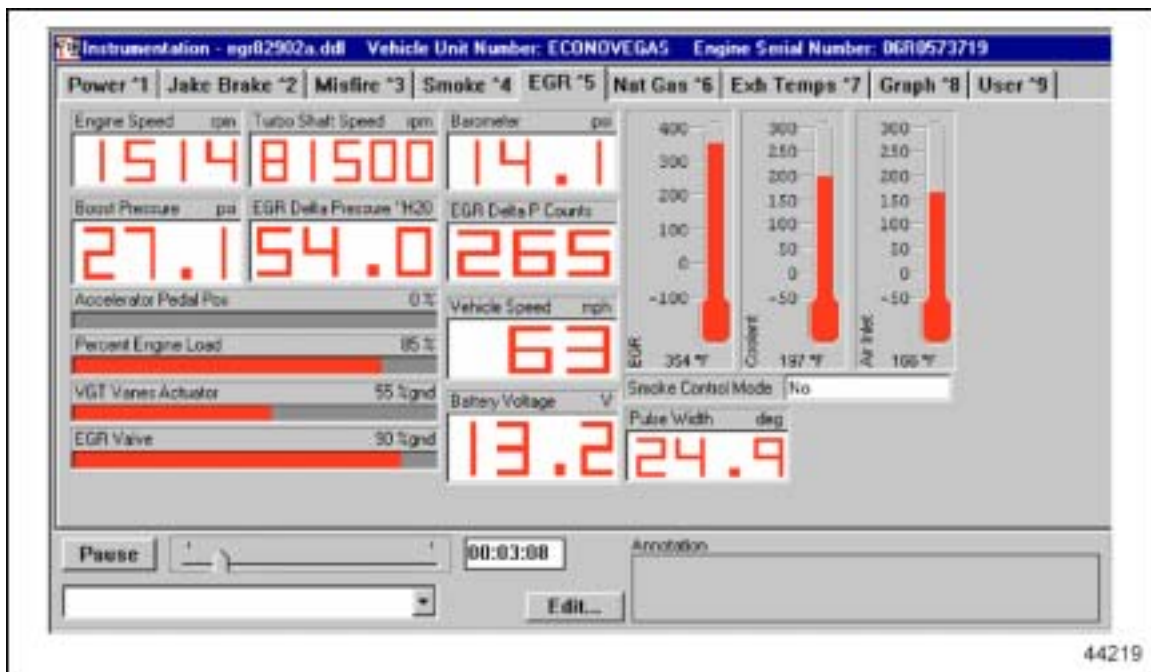

## Graph Window

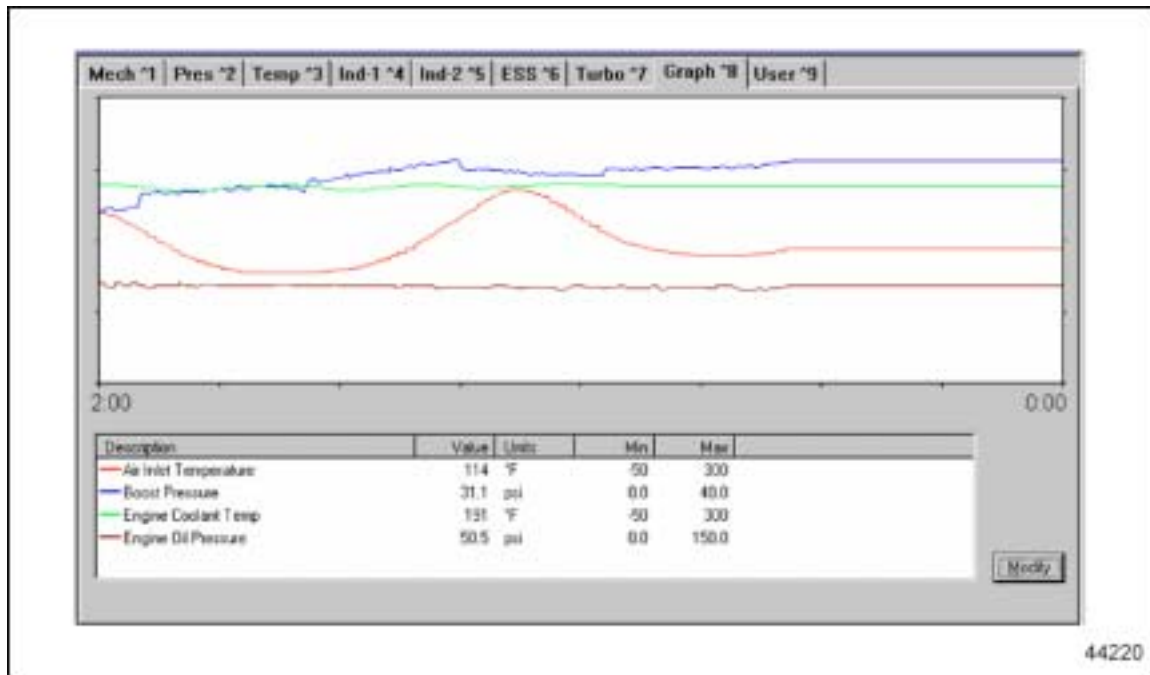

## User Window



### Fault Codes Window

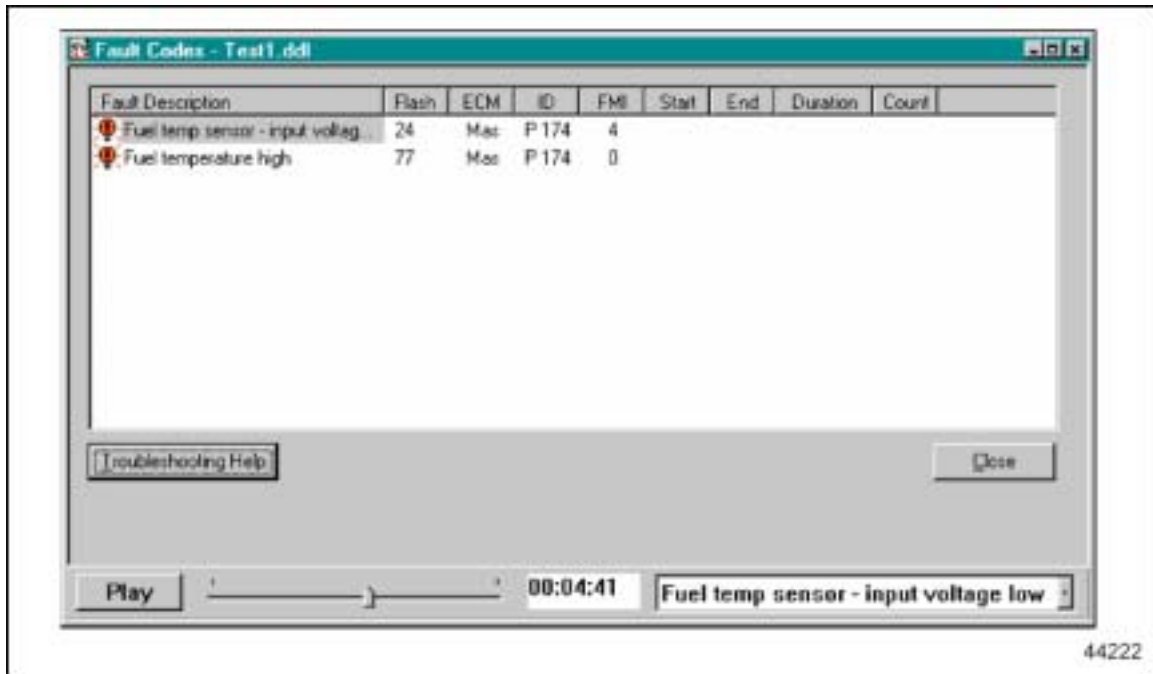

44222



## 7 SNAPSHOT EXAMPLES

### SNAPSHOT EXAMPLES

The following snapshots are intended to show you how to “interpret” the information recorded. Use the examples to try to determine what area contains the fault.

Due to the variety of operating conditions that affect actual EGR flow and Turbo boost or speed readings, the following examples **SHOULD NOT** be used as a good vs. bad criteria.

Each snapshot that follows was controlled during running on a chassis dynamometer.

Some **failures** were induced to display the logic used to determine what is wrong with a particular area of the engine.

- Idle operation with EGR. See Figure 7-1.
- Cold Idle operation without EGR flow. See Figure 7-2.
- Throttling without load, EGR is on and off. See Figure 7-3.
- 1500 rpm throttling no EGR. See Figure 7-4.
- EGR Valve stuck open. See Figure 7-5.
- 147 14, EGR Flow too Low. See Figure 7-6.
- 146 2 EGR leak – boost. See Figure 7-7.
- Leaking Charge Air Cooler. See Figure 7-8.
- Delta P port plugged (graph). See Figure 7-9.
- Normal Acceleration – Automatic Transmission. See Figure 7-10.
- Typical EGR flow loaded. See Figure 7-11.
- Normal Operation EGR off, Colder ambient. See Figure 7-12.
- Plugged Delta P port (EGR tab). See Figure 7-13.

### Normal Engine Operation as Viewed With DDDL Snapshots

It is important to understand what **Normal** looks like During normal engine operation, all parameters should have smooth transitions.

Review the snapshots in this section for examples of normal engine operation.

## EGR Flow at Idle

Detroit Diesel EGR Engines will flow EGR @ idle, as certain conditions are met. MY-2002 EGR engines will flow EGR for a short duration if DDEC determines a quick rise (snap-acceleration) in engine rpm's over time. Engine parameters programmed determine the duration of EGR flow. There is a time duration difference between MY-2002/03 - 2004.

## Delta P Sensor and Piping

The Delta P sensor monitors the pressure differential across the venturi by readings from the two openings in the delivery pipe.

### High Delta P with NO Flow Demand (PWM2 % = 7)

If the EGR valve is closed (7%) and the EGR temperature is between inlet manifold and engine temperature there should be little to no actual EGR flow. If the Delta P sensor is registering a high differential pressure in this condition:

- Check for the pressure signal pipe of hose to one side of the sensor is plugged or leaking (includes sensor mounting o rings).
- The sensor being defective is the least likely.
- Incorrectly wired (replacement sensor).

### Low Delta P with Flow Demand (PWM2 % greater than 7 and less than 90)

If the EGR valve is open and the EGR temperature is elevated there should EGR flow.

If the Delta P sensor is registering a low differential pressure in this condition: it is likely that the pressure signal to both sides of the sensor are plugged or leaking Lastly, a defective sensor.

## Stuck or Sticking VNT or EGR Valve Actuator

When the actuator is sticking, DDEC can't control turbocharger speed or EGR flow smoothly. Turbocharger speed and PWM 4- VNT % will fluctuate greatly. If the EGR actuator is sticking you are able to see EGR flow with the PWM2 % staying at 7% (which is closed). The engine's temperature can be a factor in this operation.

DDEC is attempting to control turbocharger speed and is overcompensating with PWM4 in an attempt to control turbocharger speed.

## Turbocharger Speed Sensor Faults

Turbocharger speeds rarely exceed 100,000 rpm for any length of time. Speeds exceeding 100krpm and dropping rapidly is a warning sign. 30krpm changes in speed at 1 second intervals is almost impossible. Consider a false signal being sent to the ECM rather than this event actually occurring. The ECM is responding to the signals it is receiving from sensors.

Monitor the turbocharger speed and the engine boost, watch for normal, expected changes. Note in one of the next snap shot samples that the turbocharger speed reaches 108,000 rpm and boost is only 7.1psi. Turbo Speed Sensors (pn 23530252) that have a date code stamped on the sensor connector between 0703 to 3703 should be changed first if suspect then contact DDC Technical Service for further assistance.

### **NOTE:**

Remember that if a sensor fails and sends a signal to the ECM that is within a normal threshold for that sensor. No code will be generated however DDEC could try to respond to the false signal.

### **VPOD**

The Variable Pressure Orifice (or Output) Device is used to control the pressure to the actuators used for the EGR valve and turbocharger vane position. The most common failure is external leakage of air. You can hear the leak when you activate the PWM for each VPOD.

## Relative Humidity/Turbo Compressor Inlet Temperature Sensor

This sensor is a DDC part installed and wired by the OEM. Most faults here have been due to incorrectly wired 10 pin connector. The ECM will usually log a fault code for one or the other side this combination sensor.

## Turbo Compressor Outlet Temperature

During heavy loaded operation the outlet of the turbo to the charge air cooler becomes very hot. Logic built into DDEC allows for derating of torque to reduce these temperatures to prevent charge air cooler failures. The derate code (flash code 49) of 404 14 logs without turning on the check engine light. This inactive code is stored to allow technicians the ability to assure the driver there is not any fault of failure and this operation is normal to the EGR system.

## EGR Flow Troubleshooting Tips

EGR Flow Troubleshooting Tips

IF Delta P counts are	AND EGR Temp is	AND PWM 2 % is	Indicates	Possible Cause
86-135	< Coolant temp	7%	Normal operation: No flow requested, No flow detected	No failure
86-135	> Coolant Temp	>7%	high EGR temp suggests flow, No Delta P, Flow requested	BOTH delta P ports plugged or defective delta P
86-135	> Coolant Temp	7%	(Black smoke, No code) High EGR temp indicates flow No flow requested (7%), No delta P	BOTH failed delta P (or plugged ports) AND Leaking EGR Valve
>136	< Coolant temp	7%	Low EGR temp and no flow requested; Delta P high	ONE Delta P port plugged or leaking
86-135	< Coolant temp	>7%	Low Delta P and Low coolant temp=No Flow...Flow requested	EGR Valve stuck Closed/Plugged Cooler
>136	> Coolant Temp	7%	High delta P, High EGR temp = Flow... No flow requested	EGR Valve Stuck Open
>136	> Coolant Temp	>7%	Normal operation: High delta P, High EGR temp = Flow...Flow requested	No failure

Indicates out of range condition

< = Less than  
> = Greater than



Examples

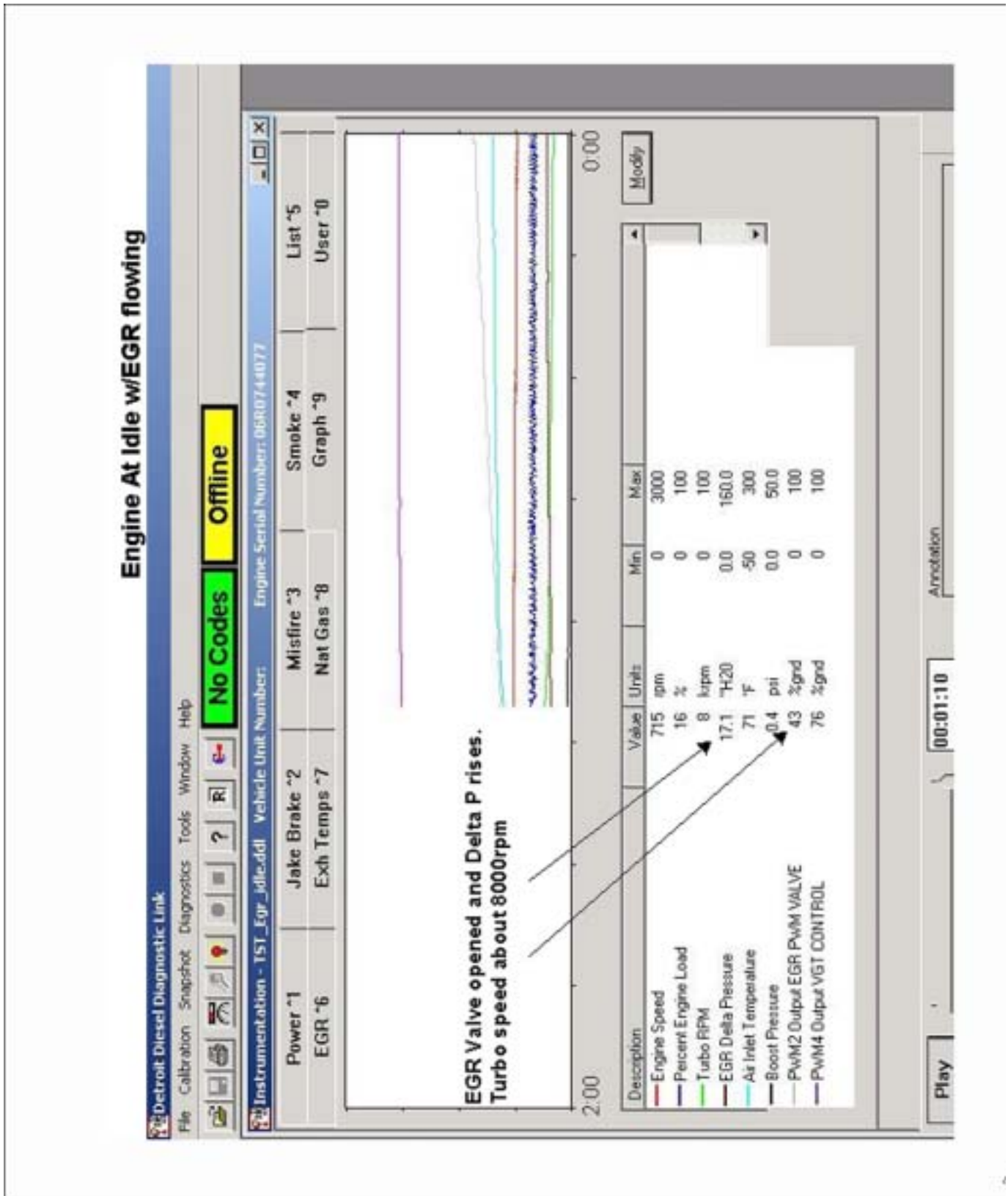

Figure 7-1 Engine at Idle with EGR Flowing

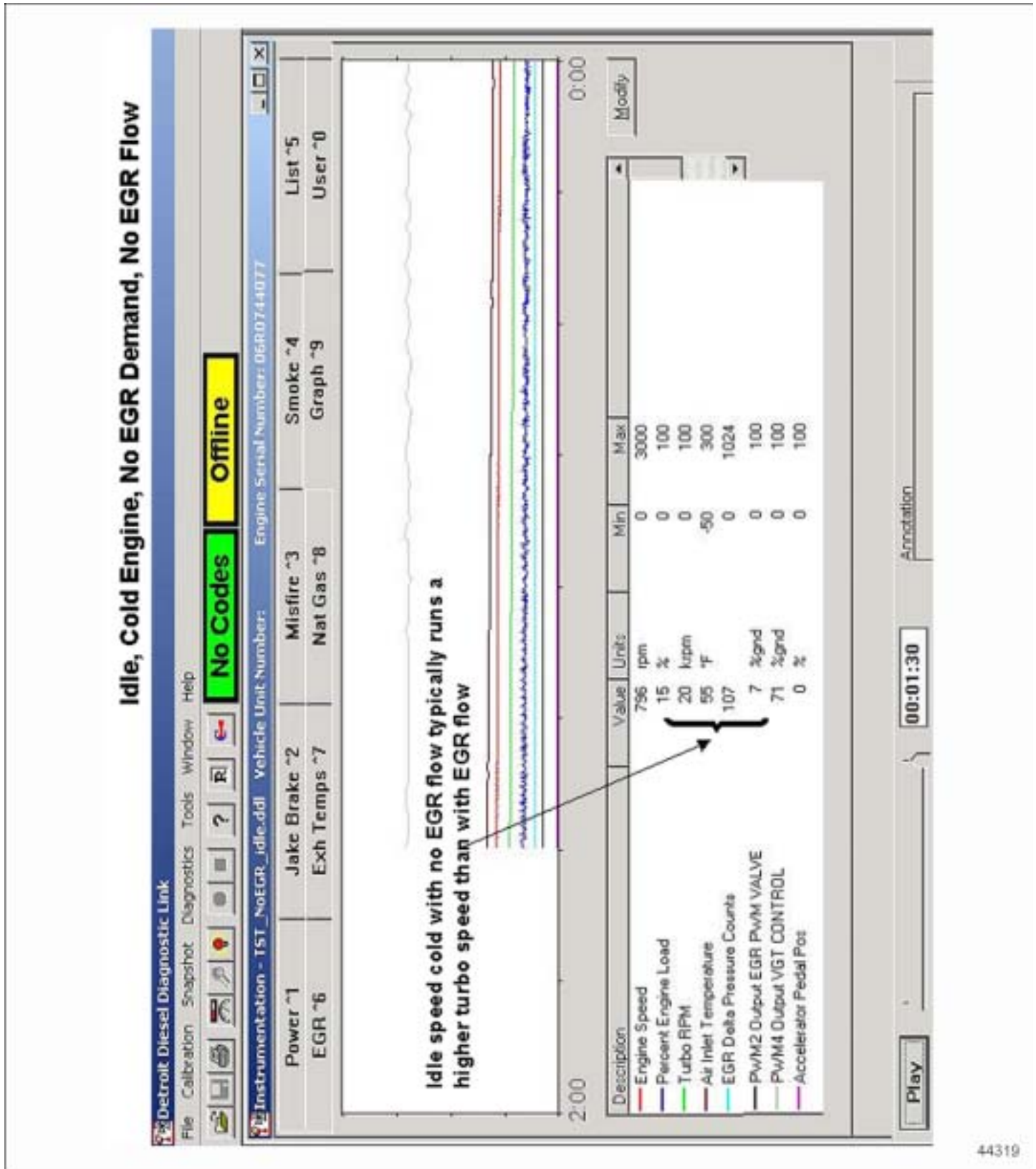

Figure 7-2 Idle — Cold Engine — No EGR Demand — No EGR Flow

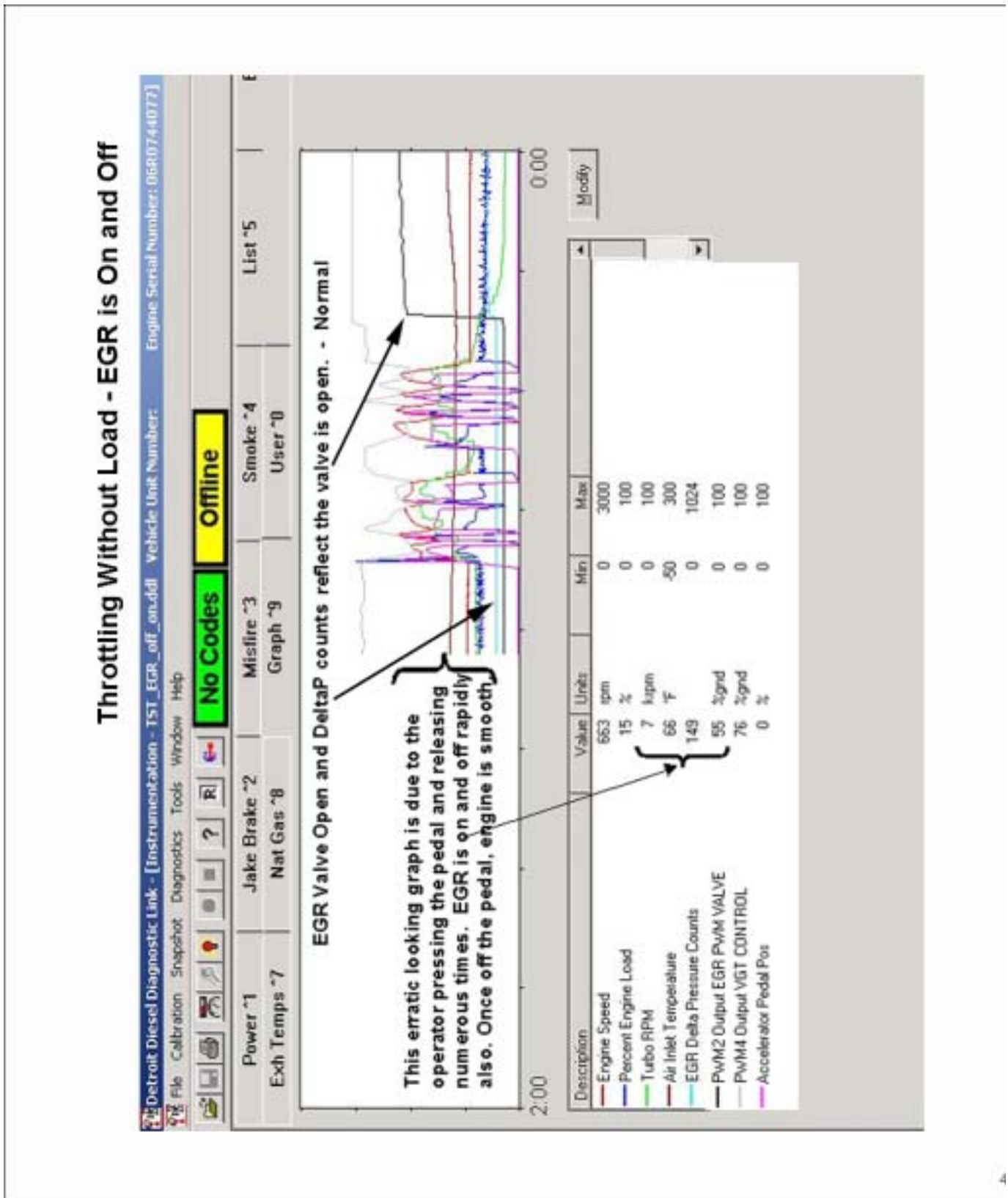

Figure 7-3 Throttling Without Load — EGR is On and Off

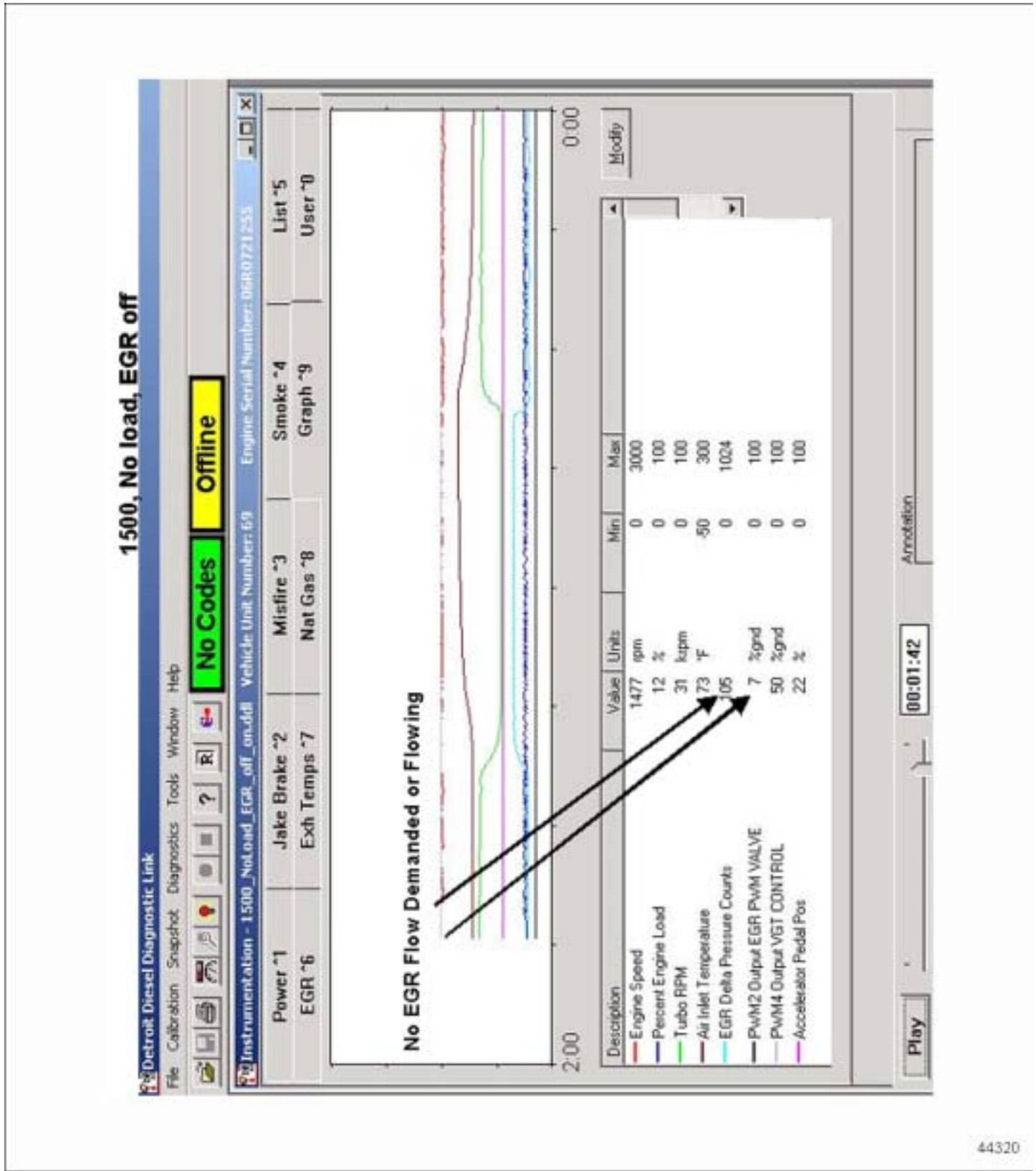

Figure 7-4    1500 — No Load — EGR Off



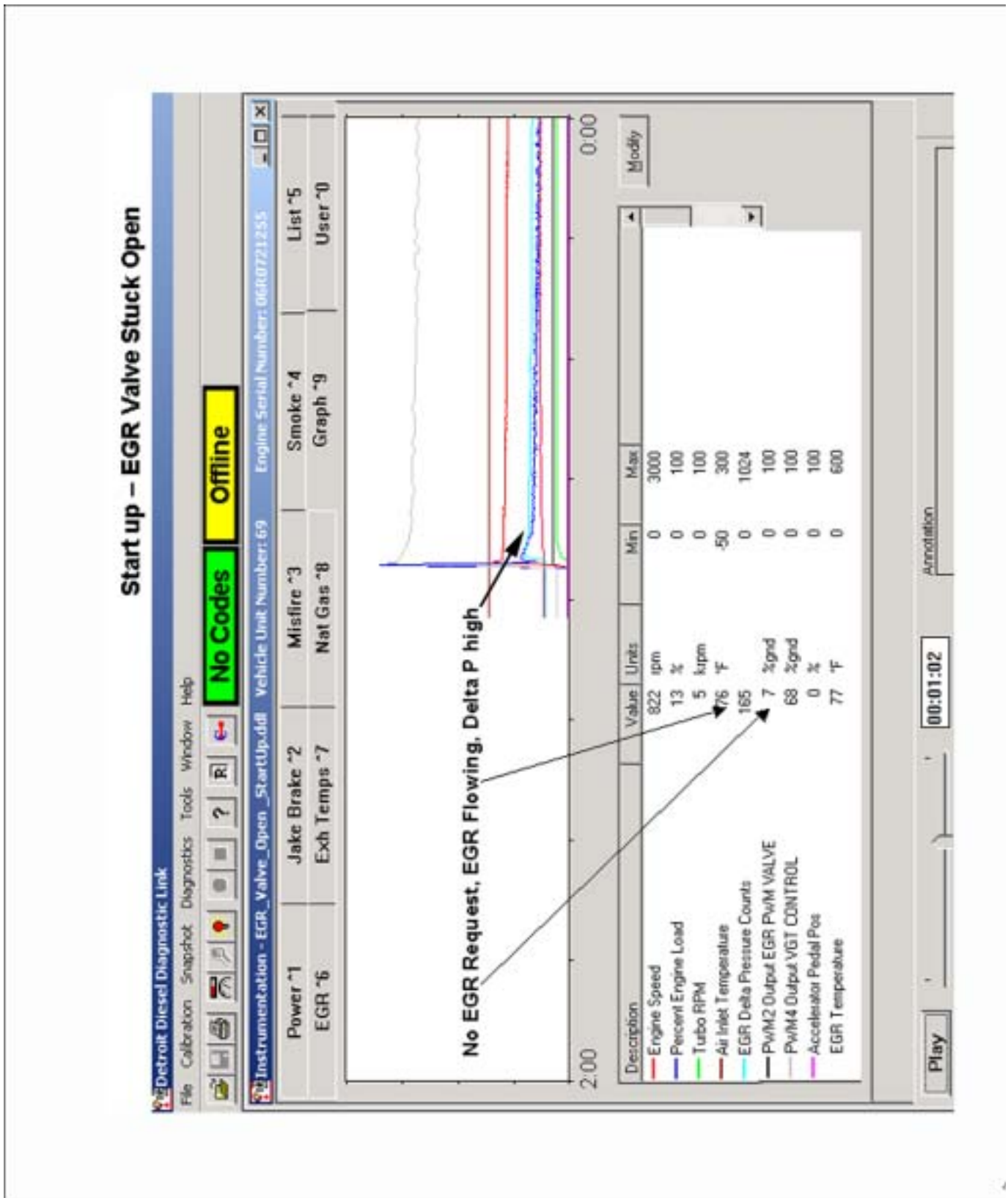

Figure 7-5 Start Up — EGR Valve Stuck Open

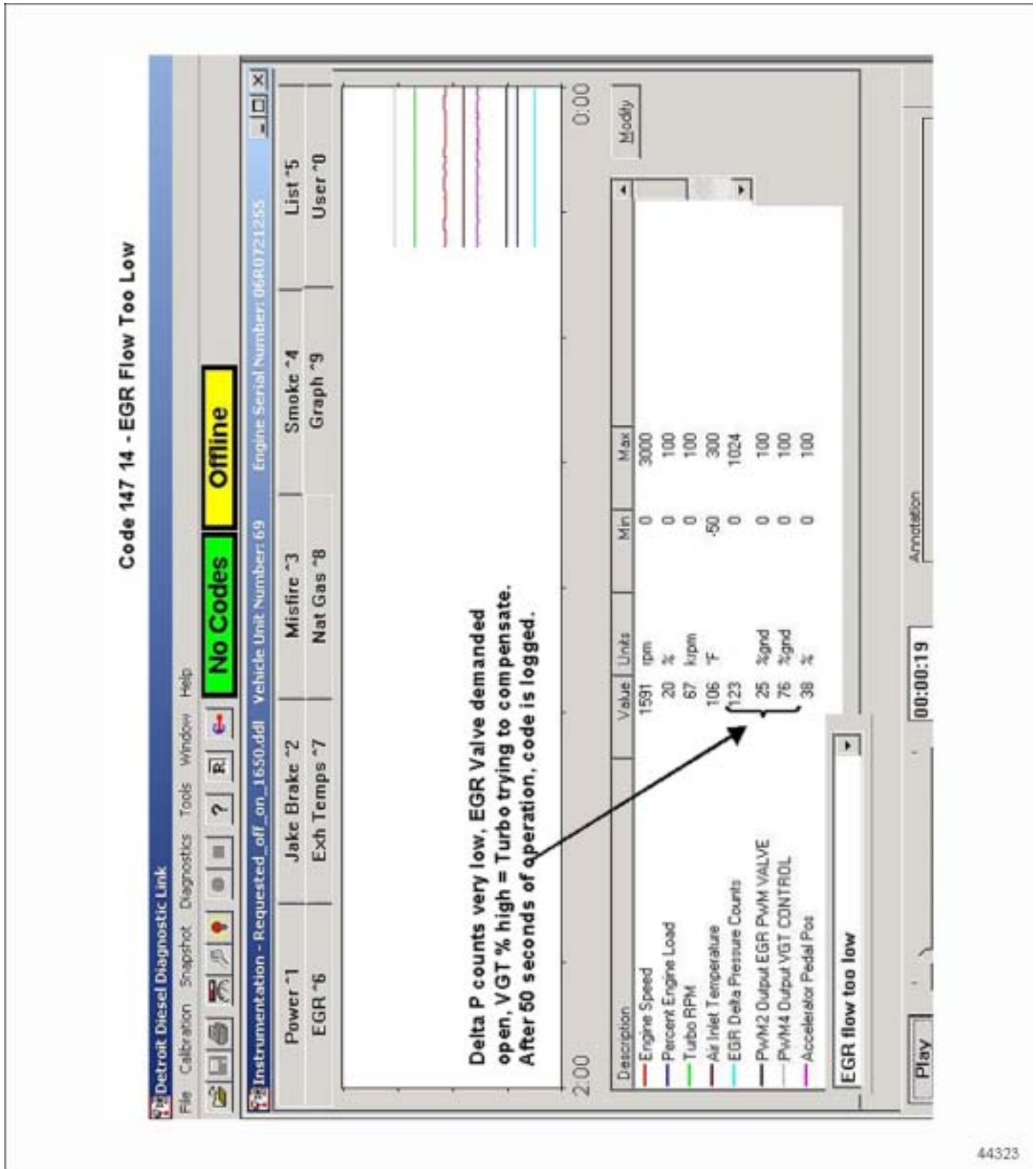

Figure 7-6 Code 147 14 — EGR Flow Too Low

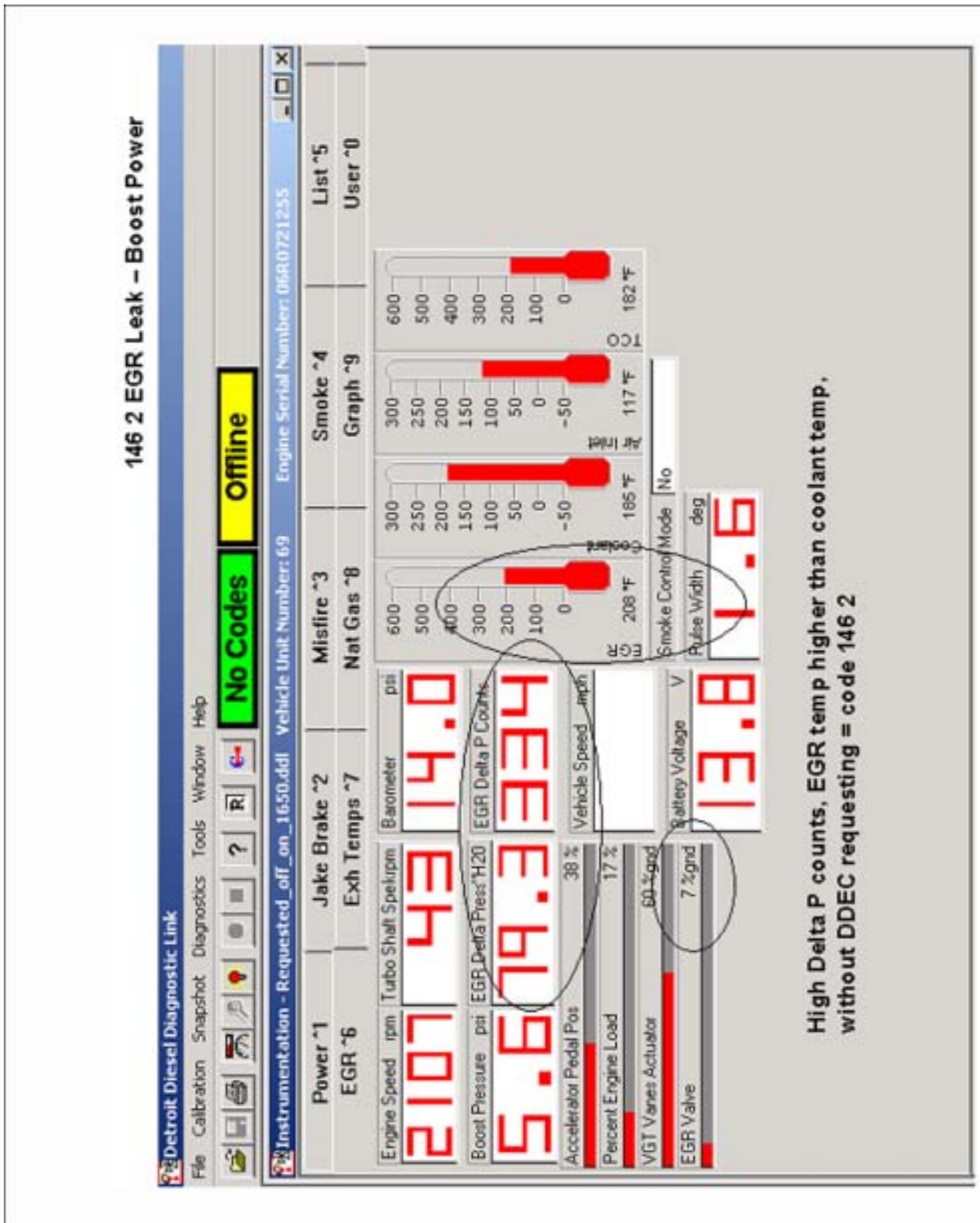

Figure 7-7 146 2 EGR Leak — Boost Power

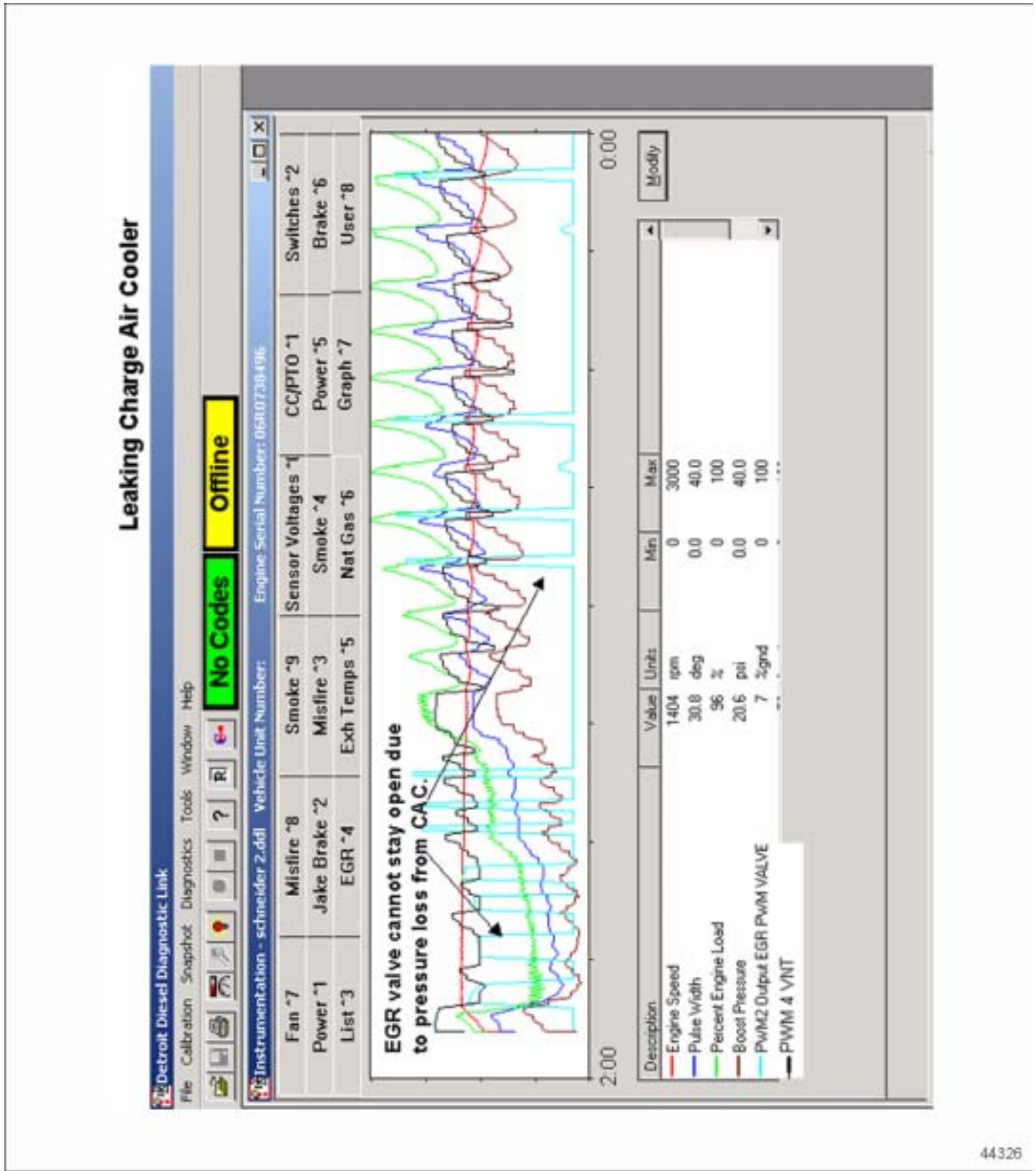
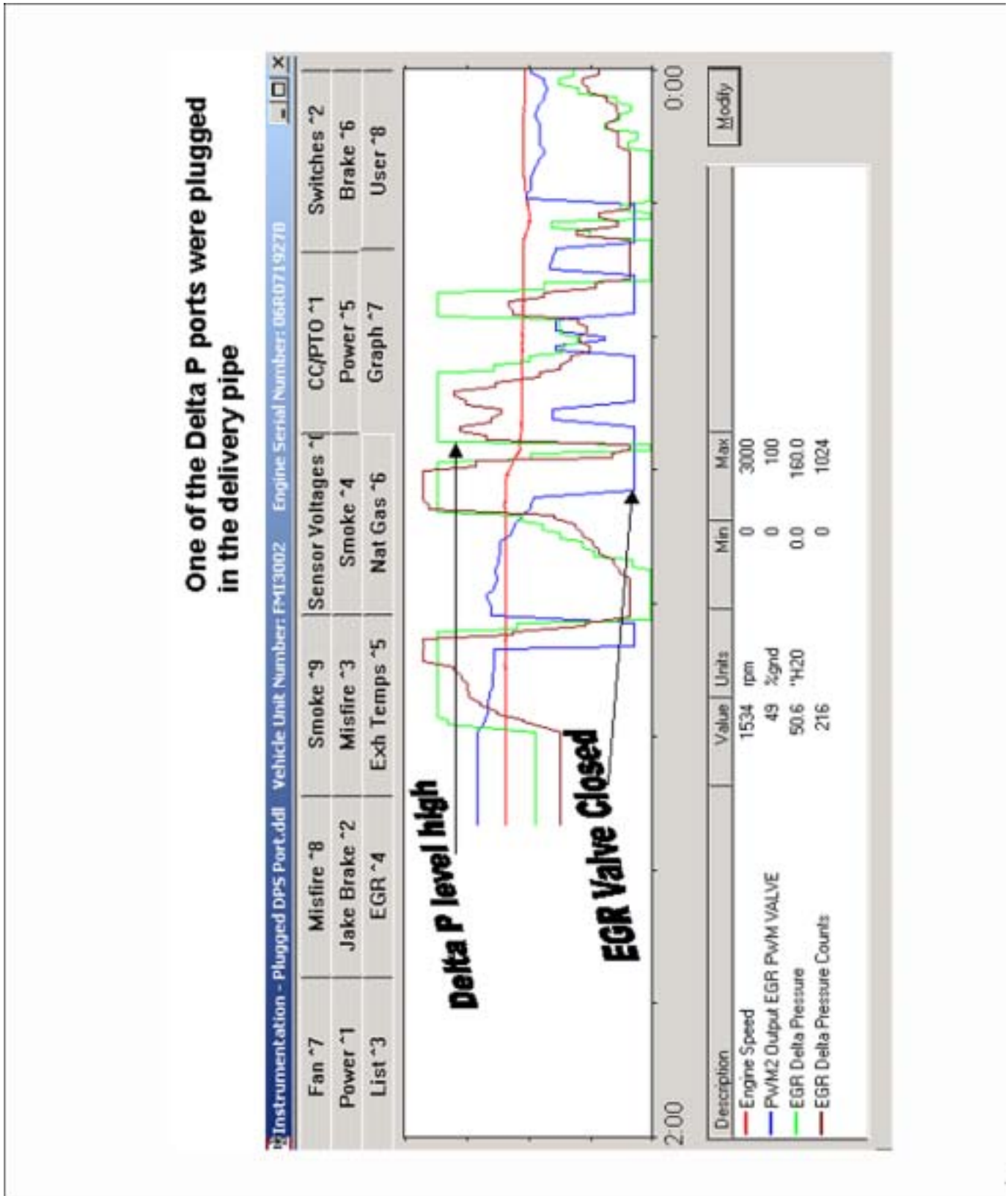

Figure 7-8 Leaking Charge Air Cooler





**Figure 7-9 One of the Delta P Ports Plugged in the Delivery Pipe**

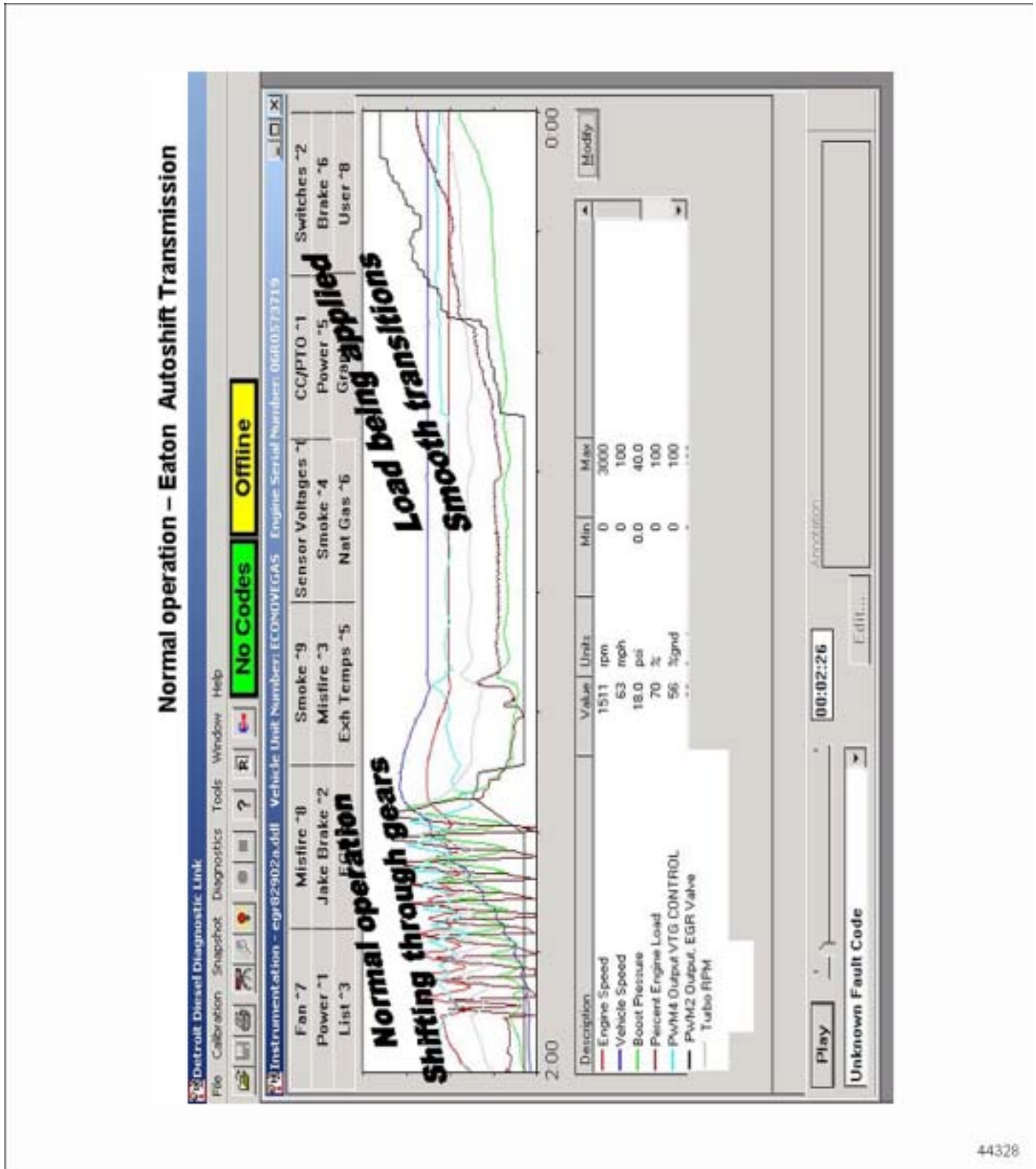

Figure 7-10 Normal Operation — Eaton Autoshift Transmission

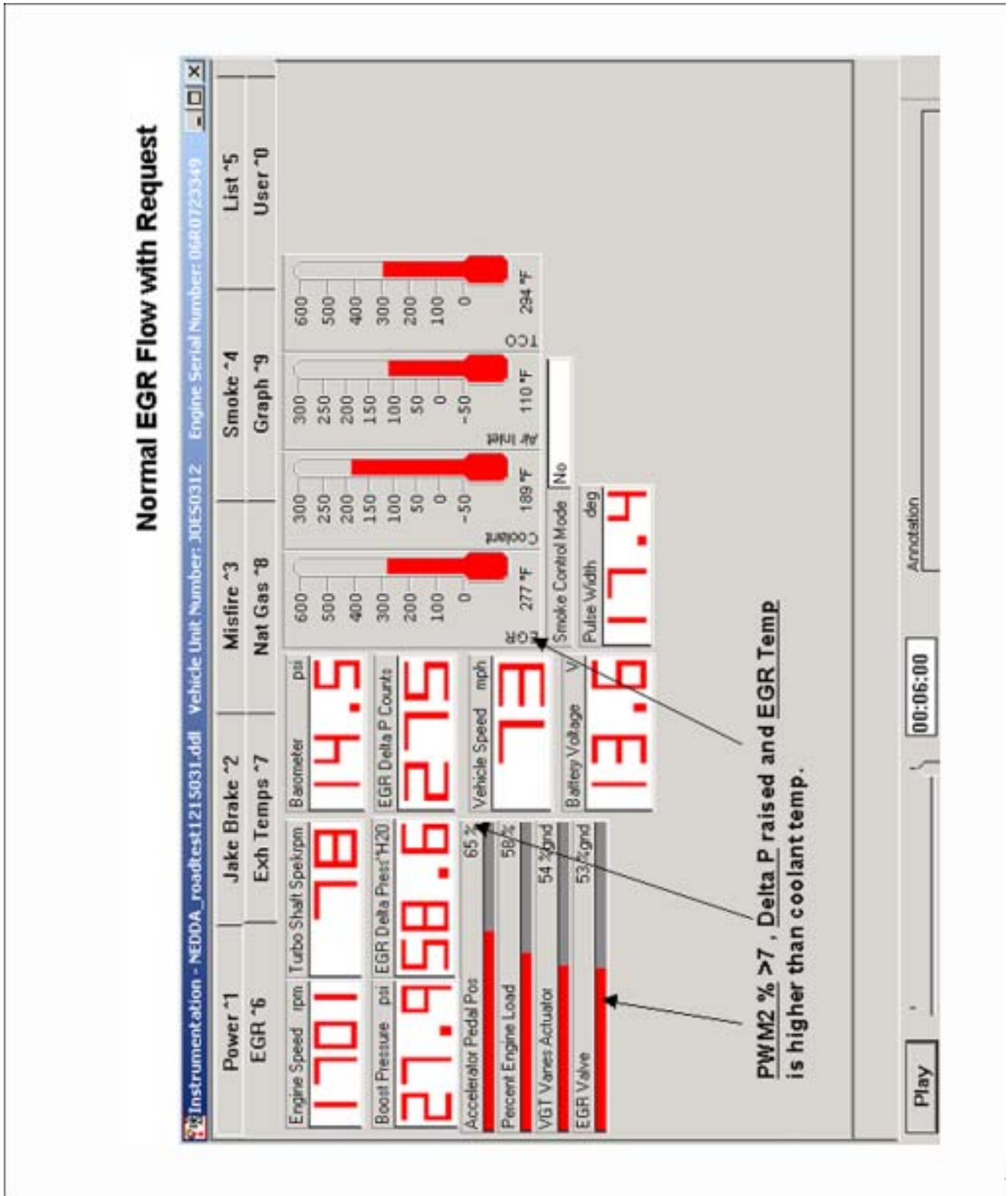

Figure 7-11 Normal EGR Flow with Request

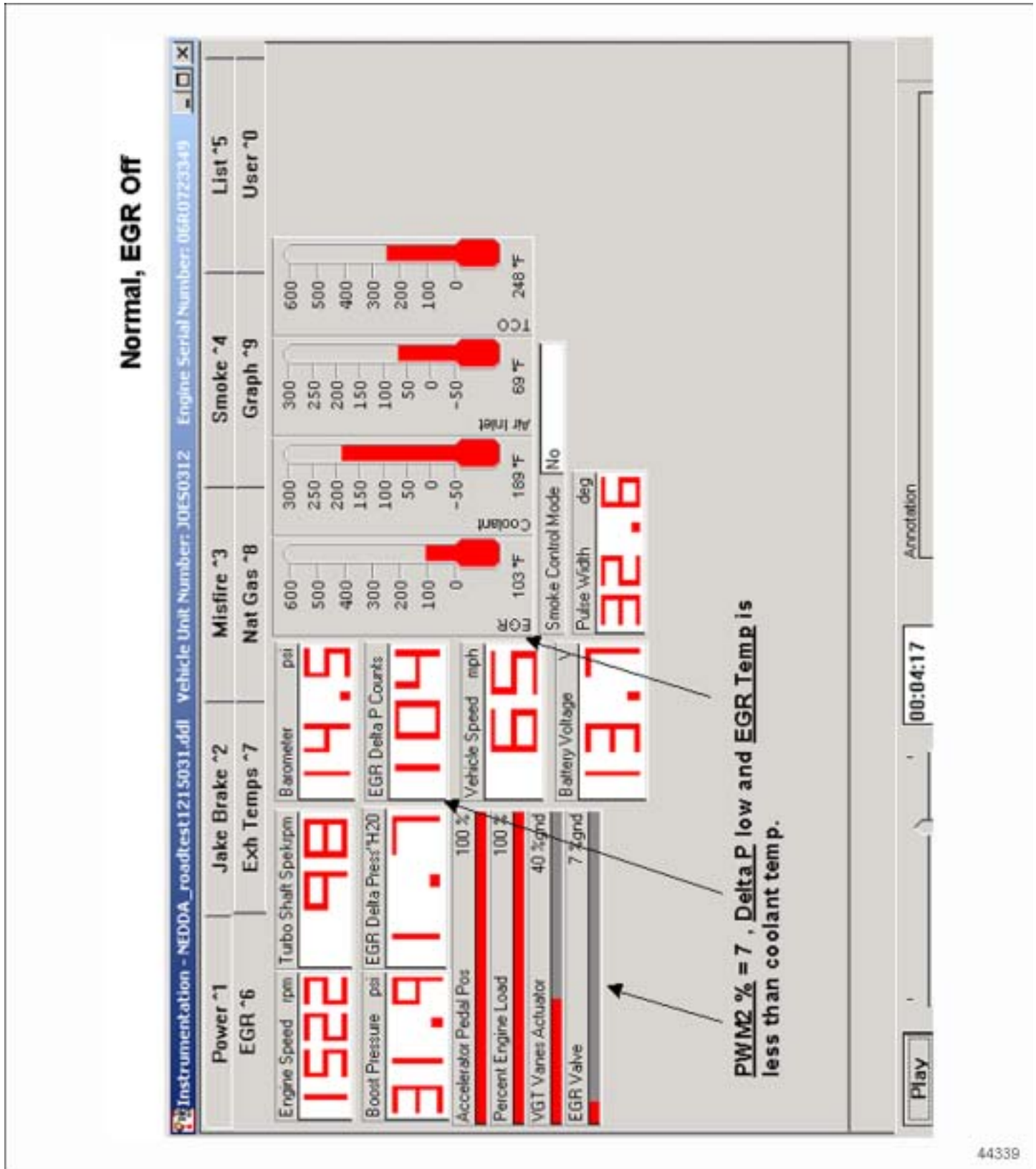

Figure 7-12 Normal — EGR Off



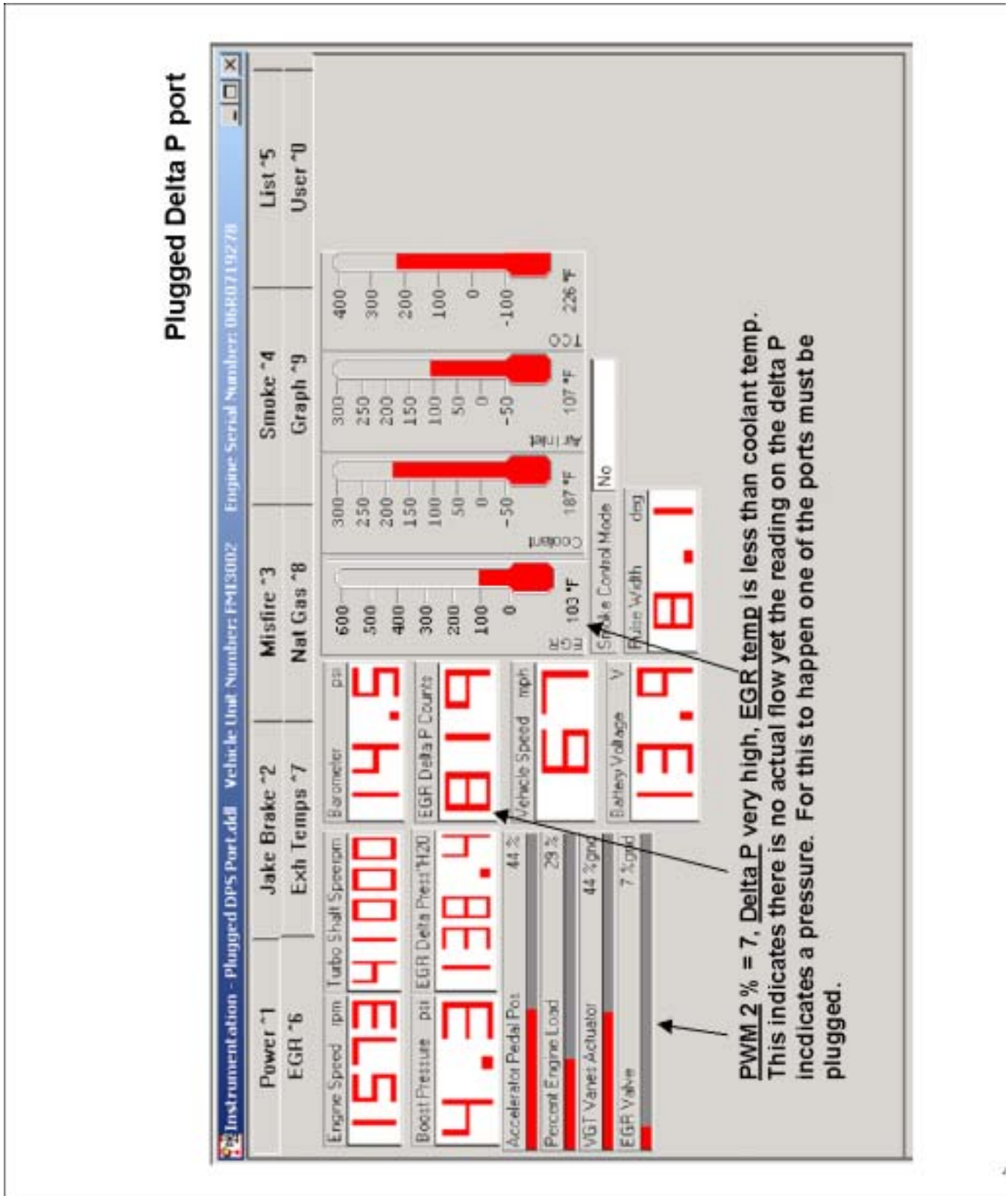

Figure 7-13 Plugged Delta P Port



## 8 DDEC V COMPONENTS

The next generation of the Series 60 EGR engine includes several new features including a more robust EGR system design.

- Enhanced DDEC ECU
- Hydraulic actuated EGR Valve
- Tube and Shell EGR Cooler

**NOTE:**

**DDDL software Level 6.0 and higher will be the primary diagnostic tool.** A diagnostic tool which is not PC supported will not have the ability to diagnose a DDEC V ECU.

## DDEC V COMPONENTS

### DDEC V Electronic Control Unit

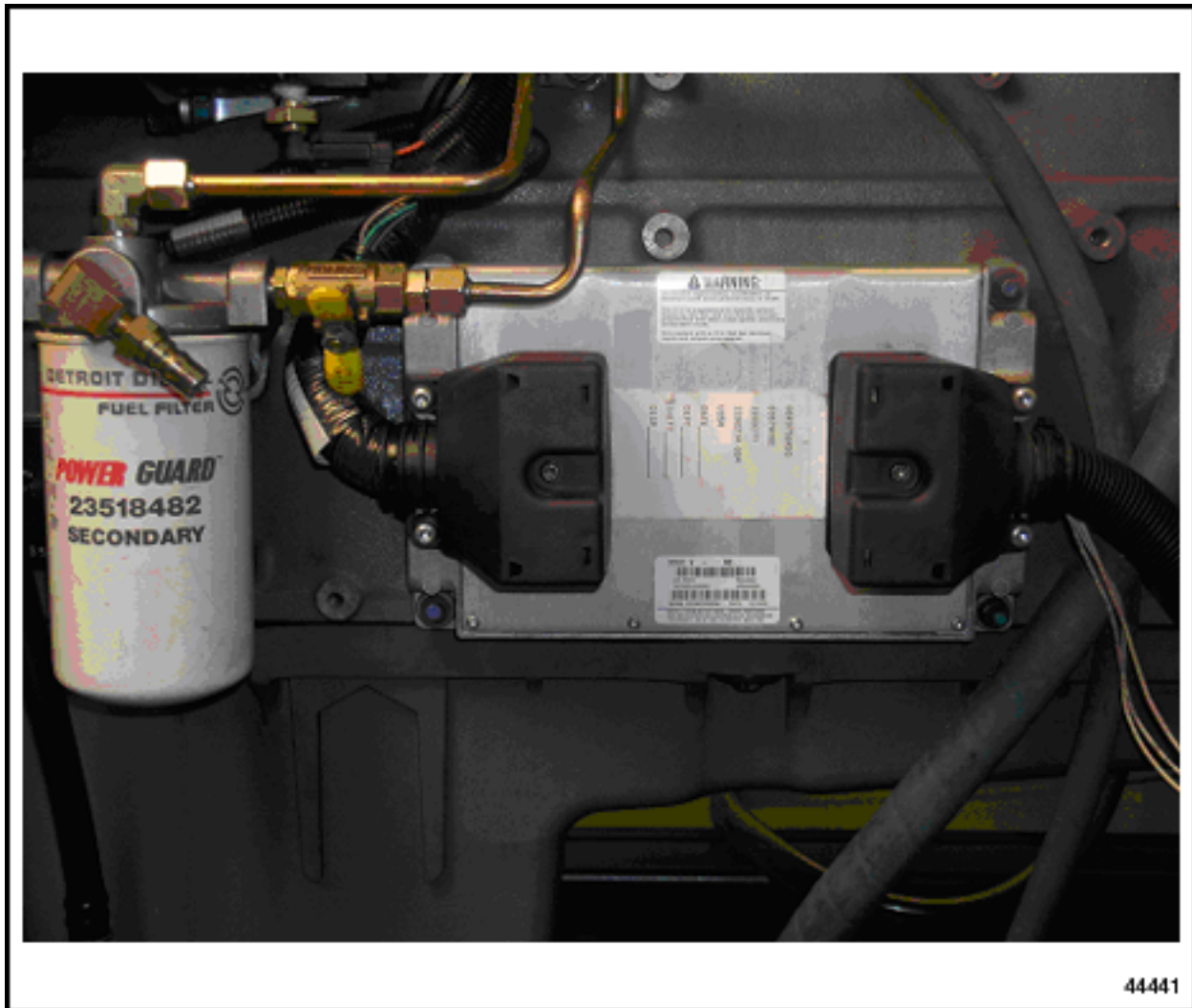

**Figure 8-1 DDEC V ECU**

DDEC V offers these advantages over previous DDEC releases (see Figure 8-1):

- Utilizes New Connectors for Improved Reliability and Harness Design
- More Input and Output Pins (up to 136 vs 81)
- More flexible inputs - 57 Analog channels vs 19 Analog + 12 Digital in DDEC IV. Up to 27 of these input channels can be configured as Digital inputs
- Frequency inputs: 6 vs 4
- Digital outputs: 19 (8 Hi, 11 Lo) vs 10 (2 Hi, 8 Lo)
- PWM outputs: 6 vs 4 (Lo side)
- Has full support for J1587 and J1939 Data Links



DDEC V offers end users significant operating advantages such as:

- State-of-the-art fuel management and economy, including compensation for changing environmental conditions and user preferences
- EPA and CARB smoke and emissions compliance
- Application specific features to meet customer needs
- Multi-level password protected security and reprogramming flexibility
- Proven reliability and durability that customers demand
- Easily accessible components, reducing maintenance time and simplifying troubleshooting
- Integrated engine protection features with lights for visual awareness
- Easily retrievable historical fault codes for diagnostic capability
- Operating statistics are tracked, fuel consumed, miles traveled (hours used), ... for accurate unit and fleet management

## Hydraulic Actuated EGR Valve

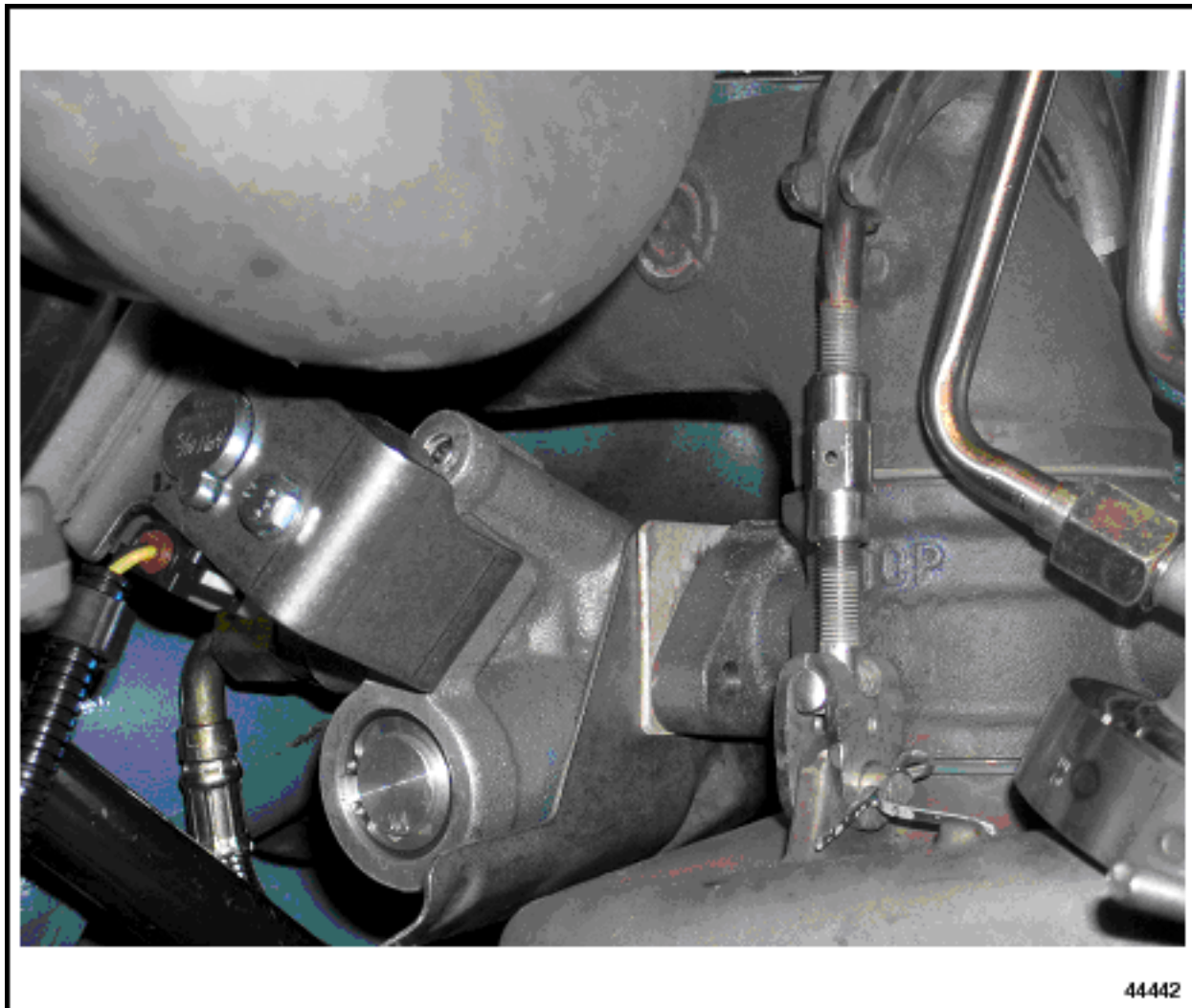

**Figure 8-2 Hydraulic Actuated EGR Valve**

The EGR Valve equipped on a DDEC V engine is a hydraulically actuated valve that operates on engine oil instead of air. This design feature eliminates the need for an EGR VPOD. The butterfly valve design is still used to control the exhaust gas flow. See Figure 8-2.

## Tube and Shell EGR Cooler

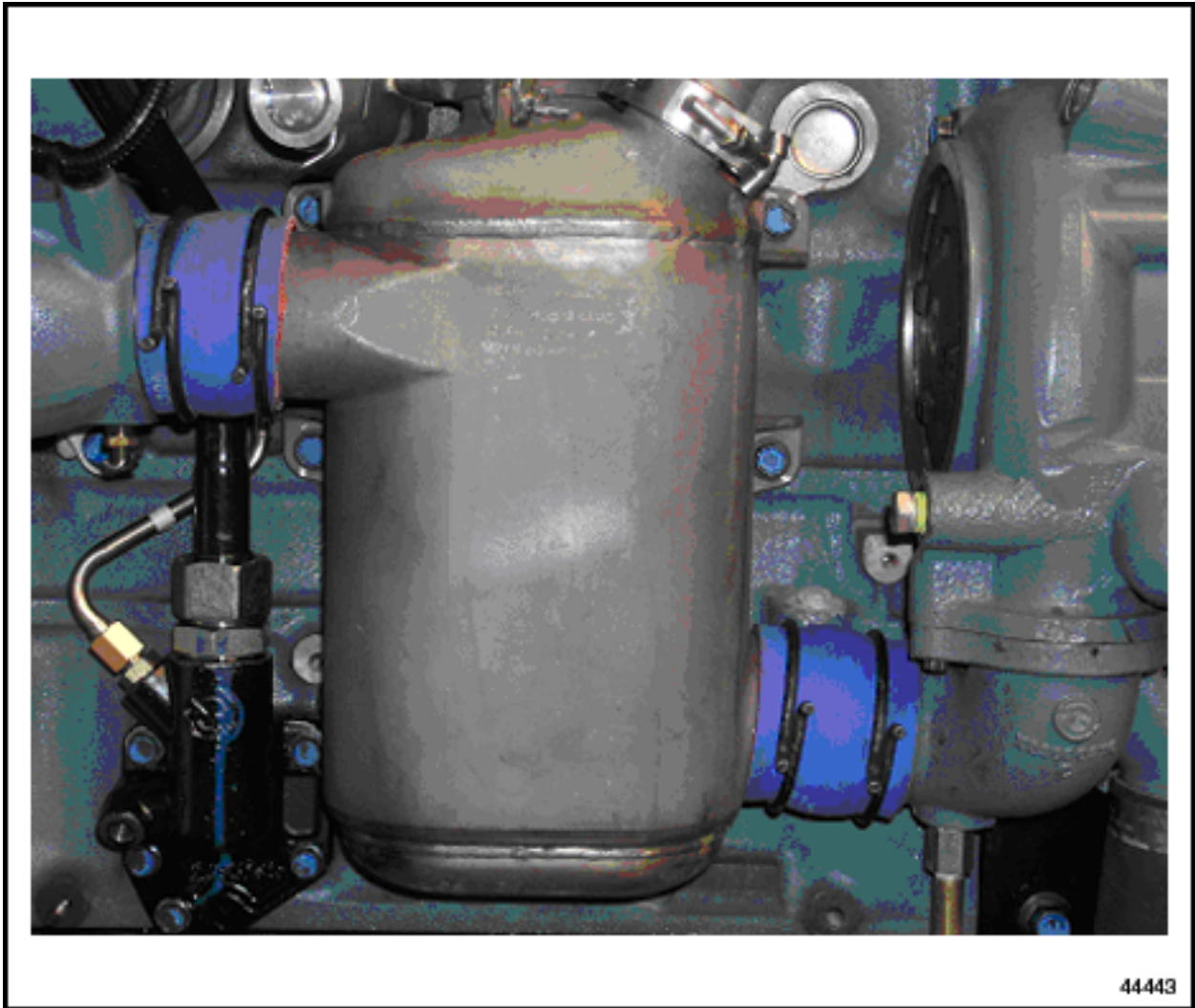

**Figure 8-3 Tube and Shell EGR Cooler**

The new EGR Cooler features a durable tube & shell core and a cast housing that have less weld joints than the previous design. See Figure 8-3.



## 9 DDEC V CODES

### DDEC V EGR DESCRIPTIONS

To read codes, use the Detroit Diesel Diagnostic Link (DDDL). The DDDL will display active and inactive fault codes which are listed in Table 9-1.

**NOTE:**

Some vehicle dashboard displays will show SAE faults.

- Yellow** = Sensor
- Red** = Protection
- Blue** = Logic
- Green** = MAS (Maintenance Alert System)

DDC Code # (Flashed)	PID	SID	FMI	Description
11	187	-	4	Variable Speed Governor Sensor Voltage Low
11	187	-	7	Variable Speed Governor Switch System Not Responding
12	187	-	3	Variable Speed Governor Sensor Voltage High
13	111	-	4	Coolant Level Sensor Input Voltage Low
13	111	-	6	Add Coolant Level Sensor Input Voltage Low
13	-	146	6	EGR Valve Current Too High
14	110	-	3	Coolant Temperature Sensor Input Voltage High
14	175	-	3	Oil Temperature Sensor Input Voltage High
15	110	-	4	Coolant Temperature Sensor Input Voltage Low
15	175	-	4	Oil Temperature Sensor Input Voltage Low
16	111	-	3	Coolant Level Sensor Input Voltage High
16	111	-	5	Add Coolant Level Sensor Input Voltage High
16	-	146	5	EGR Valve Current Too Low
21	91	-	3	Throttle Position Sensor Input Voltage High
22	91	-	4	Throttle Position Sensor Input Voltage Low
23	174	-	3	Fuel Temperature Sensor Input Voltage High
24	174	-	4	Fuel Temperature Sensor Input Voltage Low
25	-	-	-	Reserved for "No Codes"
26	-	25	11	Aux. Shutdown #1 Active
26	-	61	11	Aux. Shutdown #2 Active

DDC Code # (Flashed)	PID	SID	FMI	Description
27	105	-	3	Intake Manifold Temperature Sensor Input Voltage High
27	171	-	3	Ambient Air Temperature Sensor Input Voltage High
27	172	-	3	Air Temperature Sensor Input Voltage High
28	105	-	4	Intake Manifold Temperature Sensor Input Voltage Low
28	171	-	4	Ambient Air Temperature Sensor Input Voltage Low
28	172	-	4	Air Temperature Sensor Input Voltage Low
29	351	-	4	TCI Temperature Circuit Failed Low
29	404	-	4	Turbo Compressor Temperature Out Sensor Input Voltage Low
31	-	51	3	Aux. Output #3 Open Circuit (High Side) - E49
31	-	51	4	Aux. Output #3 Short To Ground (High Side) - E49
31	-	51	7	Aux. Output #3 Mechanical System Fail - E49
31	-	52	3	Aux. Output #4 Open Circuit (High Side) - E48
31	-	52	4	Aux. Output #4 Short to Ground (High Side) - E48
31	-	52	7	Aux. Output #4 Mechanical System Failure - E48
31	-	260	3	Aux. Output #12 (E46) Open Circuit (High Side)
31	-	260	4	Aux. Output #12 (E46) Short To Ground (High Side)
31	-	260	7	Aux. Output #12 (E46) Mechanical System Failure (High Side)
31	-	261	3	Aux. Output #13 (E47) Open Circuit (High Side)
31	-	261	4	Aux. Output #13 (E47) Short To Ground (High Side)
31	-	261	7	Aux. Output #13 (E47) Mechanical System Failure
31	-	262	3	Aux. Output #14 (E50) Open Circuit (High Side)
31	-	262	4	Aux. Output #14 (E50) Short To Ground (High Side)
31	-	262	7	Aux. Output #14 (E50) Mechanical System Failure (High Side)
31	-	263	3	Aux. Output #15 (E51) Open Circuit (High Side)
31	-	263	4	Aux. Output #15 (E51) Short To Ground (High Side)
31	-	263	7	Aux. Output #15 (E51) Mechanical System Failure
31	-	264	3	Aux. Output #16 (E52) Open Circuit (High Side)
31	-	264	4	Aux. Output #16 (E52) Short To Ground (High Side)
31	-	264	7	Aux. Output #16 (E52) Mechanical System Failure
31	-	265	3	Aux. Output #17 (E53) Open Circuit (High Side)
31	-	265	4	Aux. Output #17 (E53) Short To Ground (High Side)
31	-	265	7	Aux. Output #17 (E53) Mechanical System Failure
32	-	238	3	RSL Short to Battery (+)
32	-	238	4	RSL Open Circuit
32	-	239	3	AWL Short to Battery (+)
32	-	239	4	AWL Open Circuit
33	102	-	3	Turbo Boost Pressure Sensor Input Voltage High
34	102	-	4	Turbo Boost Pressure Sensor Input Voltage Low
35	100	-	3	Oil Pressure Sensor Input Voltage Low

DDC Code # (Flashed)	PID	SID	FMI	Description
36	100	-	4	Oil Pressure Sensor Input Voltage Low
37	94	-	3	Fuel Pressure Sensor Input Voltage High
37	95	-	3	Fuel Restriction Sensor Input Voltage High
38	94	-	4	Fuel Pressure Sensor Input Voltage Low
38	95	-	4	Fuel Restriction Sensor Input Voltage Low
39	-	146	2	EGR Leak - Boost Power
39	-	146	7	EGR Valve Not Responding
39	-	146	12	EGR Leak - Boost Jake
39	-	147	2	VNT Vanes Not Responding - Boost Power
39	-	147	7	VNT Vanes Not Responding-EGR
39	-	147	11	VNT Vanes at Max - Jake
39	-	147	12	VNT Vanes Not Responding - Boost Jake
39	-	147	14	EGR Flow too Low
41	-	21	0	Too Many SRS (missing TRS)
42	-	21	1	Too few SRS (missing SRS)
43	111	-	1	Coolant Level Low
44	105	-	0	Intake Manifold Temperature High
44	105	-	14	Engine Power Derate Due To Intake Manifold Temperature
44	110	-	0	Coolant Temperature High
44	110	-	14	Engine Power Derate Due To Coolant Temperature
44	172	-	0	Air Inlet Temperature High
44	175	-	0	Oil Temperature High
44	175	—	14	Oil Temperature Derate
45	100	-	1	Oil Pressure Low
46	-	155	4	Injector Vreg Voltage Failed Low
46	168	-	1	ECU Battery Voltage Low
46	-	211	1	Vehicle Sensor Supply Voltage Low
46	-	212	4	Injector Vslope Voltage Failed Low
46	-	214	1	RTC Backup Battery Voltage Low
46	-	221	4	Injector ILpullin Voltage Failed Low
46	-	232	1	Sensor Supply Voltage Low
47	94	-	0	Fuel Pressure High
47	102	-	14	Engine Power Derate Due To Boost Pressure
47	102	-	0	Turbo Boost Pressure High
47	106	-	0	Air Inlet Pressure High
48	94	-	1	Fuel Pressure Low
48	106	-	1	Air Inlet Pressure Low
48	351	-	1	TCI Temperature Below Range
48	404	-	1	Turbo Compressor Temperature Out Low
48	411	-	1	EGR Delta Pressure Low
48	412	-	1	EGR Temperature Low

DDC Code # (Flashed)	PID	SID	FMI	Description
49	351	-	0	TCI Temperature Above Range
49	404	-	0	Turbo Compressor Out Temperature High
49	404	14	-	Engine Power Derate Due To TCO Temperature
51	351	-	3	TCI Temperature Circuit Failed High
51	404	-	3	Turbo Compressor Out Temperature Sensor Input Voltage High
52	-	254	12	A/D Conversion Fail
53	-	253	2	Memory Check Failed On Startup
53	-	253	12	Memory Write Error - Single Location
53	-	253	13	Calibration Memory Error
53	-	253	14	Memory Write Error - All Locations
54	84	-	12	Vehicle Speed Sensor Fault
55	-	216	14	Other ECU Fault (This fault is logged in conjunction with another fault to indicate missing information from another ECU.)
55	-	231	12	J1939 Data Link Fault
58	40	-	9	Engine Retarder Switch Not Responding
58	40	-	12	Engine Retarder Switch Failed
58	70	-	9	Park Brake/Safety Loop Switch Not Responding
58	70	-	12	Park Brake/Safety Loop Switch Failed
58	92	-	0	Torque Overload
58	-	216	7	ECU Information Not Responding (Mux'd Dashboard Devices)
58	-	242	9	Cruise Control Resume/Accel Switch Not Responding
58	-	242	12	Cruise Control Resume/Accel Switch Failed
58	-	243	9	Cruise Control Set/Coast Switch Not Responding
58	-	243	12	Cruise Control Set/Coast Switch Failed
58	-	244	9	Cruise Control Enable Switch Not Responding
58	-	244	12	Cruise Control Enable Switch Failed
58	-	245	9	Clutch Pedal Switch Not Responding
58	-	245	12	Clutch Pedal Switch Failed
58	-	246	9	Service Brake Pedal Switch Not Responding
58	-	246	12	Service Brake Pedal Switch Failed
61	-	xxx	0	Injector xxx Response Time Long
61	-	1	6	Injector #1 Circuit Short To Ground
61	-	2	6	Injector #2 Circuit Short To Ground
61	-	3	6	Injector #3 Circuit Short To Ground
61	-	4	6	Injector #4 Circuit Short To Ground
61	-	5	6	Injector #5 Circuit Short To Ground
61	-	6	6	Injector #6 Circuit Short To Ground
62	-	26	3	Aux. Output #1 Short to Battery (+) - V4
62	-	26	4	Aux. Output #1 Open Circuit - V4



DDC Code # (Flashed)	PID	SID	FMI	Description
62	-	26	7	Aux. Output #1 Mechanical System Not Responding Properly -V4
62	-	40	3	Aux. Output #2 Short to Battery (+) - V5
62	-	40	4	Aux. Output #2 Open Circuit - V5
62	-	40	7	Aux. Output #2 Mechanical System Not Responding Properly - V5
62	-	53	3	Aux. Output #5 Short to Battery (+) -V6
62	-	53	4	Aux. Output #5 Open Circuit - V6
62	-	53	7	Aux. Output #5 Mechanical System Not Responding Properly - V6
62	-	54	3	Aux. Output #6 Short to Battery (+) - V7
62	-	54	4	Aux. Output #6 Open Circuit - V7
62	-	54	7	Aux. Output #6 Mechanical System Not Responding Properly - V7
62	-	55	3	Aux. Output #7 Short to Battery (+) - V40
62	-	55	4	Aux. Output #7 Open Circuit - V40
62	-	55	7	Aux. Output #7 Mechanical System Not Responding Properly - V40
62	-	56	3	Aux. Output #8 Short to Battery (+) - V53
62	-	56	4	Aux. Output #8 Open Circuit - V53
62	-	56	7	Aux. Output #8 Mechanical System Not Responding Properly - V53
62	-	250	12	J1587 Data Link Fault
62	-	257	3	Aux.Output #9 (V54) Short To Battery
62	-	257	4	Aux.Output #9 (V54) Open Circuit
62	-	257	7	Aux.Output #9 (V54) Mechanical System Failure-Pin Top 2
62	-	258	3	Aux.Output #10 (V55) Short To Battery
62	-	258	4	Aux.Output #10 (V55) Open Circuit)
62	-	258	7	Aux.Output #10 (V55) Mechanical System Failure Top 2
62	-	259	3	Aux.Output #11 (E13) Short To Battery
62	-	259	4	Aux.Output #11 (E13) Open Circuit
62	-	259	7	Aux.Output #11 (E13) Mechanical System Failure
63	-	57	0	PWM #1 (V52) Above Normal Range
63	-	57	1	PWM #1 (V52) Below Normal Range
63	-	57	3	PWM #1 (V52) Short to Battery (+)
63	-	57	4	PWM #1 (V52) Open Circuit
63	-	57	7	PWM #1 (V52) Mechanical System Failre
63	-	58	0	PWM #2 (V46) Above Normal Range
63	-	58	1	PWM #2 (V46) Below Normal Range
63	-	58	3	PWM #2 (V46) Short to Battery (+)
63	-	58	4	PWM #2 (46) Open Circuit
63	-	58	7	PWM #1 (V46) Mechanical System Failre
63	-	59	0	PWM #3 (E01) Above Normal Range

DDC Code # (Flashed)	PID	SID	FMI	Description
63	-	59	1	PWM #3 (E01) Below Normal Range
63	-	59	3	PWM #3 (E01) Short to Battery (+)
63	-	59	4	PWM #3 (E01) Open Circuit
63	-	59	7	PWM #3 (E01) Mechanical System Failure
63	-	60	0	PWM #4 (E04) Above Normal Range
63	-	60	1	PWM #4 (E04) Below Normal Range
63	-	60	3	PWM #4 (E04) Short to Battery (+)
63	-	60	4	PWM #4 (E04) Open Circuit
63	-	60	7	PWM #4 (E04) Mechanical System Failure
63	-	267	0	PWM #5 (E08) Above Normal Range
63	-	267	1	PWM #5 (E08) Below Normal Range
63	-	267	3	PWM #5 (E08) Short To Battery
63	-	267	4	PWM #5 (E08) Open Circuit
63	-	267	7	PWM #5 (E08) Mechanical System Failure
63	-	268	0	PWM #6 (E11) Above Normal Range
63	-	268	1	PWM #6 (E11) Below Normal Range
63	-	268	3	PWM #6 (E11) Short To Battery
63	-	268	4	PWM #6 (E11) Open Circuit
63	-	268	7	PWM #6 (E11) Mechanical System Failure
64	103	-	0	Turbo Overspeed
64	103	-	8	Turbo Speed Sensor Input Failure - Abnormal Period
65	107	-	3	Air Filter Restriction Sensor Voltage High
65	107	-	4	Air Filter Restriction Sensor Voltage Low
66	99	-	3	Oil Filter Restriction Sensor Voltage High
66	99	-	4	Oil Filter Restriction Sensor Voltage Low
67	106	-	3	Air Inlet Pressure Sensor Input Voltage High
67	106	-	4	Air Inlet Pressure Sensor Input Voltage Low
67	109	-	3	Coolant Pressure Circuit Failed High
67	109	-	4	Coolant Pressure Circuit Failed Low
68	-	230	5	TPS Idle Validation Circuit Fault (open circuit)
68	-	230	6	TPS Idle Validation Circuit Fault (short to ground)
71	-	xxx	1	Injector xxx Response Time Short
72	84	-	0	Vehicle Overspeed
72	84	-	11	Vehicle Overspeed (Absolute)
74	70	-	4	Optimized Idle Safety Loop Short to Ground
74	99	-	0	Oil Filter Restriction High
75	-	155	3	Injector Vreg Voltage Failed High
75	168	-	0	ECU Battery Voltage High
75	-	211	0	Vehicle Sensor Supply Voltage High
75	-	212	3	Injector Vslope Voltage Failed High
75	-	214	0	RTC Backup Battery Voltage High

DDC Code # (Flashed)	PID	SID	FMI	Description
75	-	221	3	Injector Ipullin Voltage Failed High
75	-	232	0	Sensor Supply Voltage High
76	121	-	0	Engine Overspeed With Engine Brake
77	21	-	0	ECU Temperature Above Range
77	21	-	1	ECU Temperature Below Range
77	21	-	3	ECU Temperature Failed High
77	21	-	4	ECU Temperature Failed Low
77	73	-	1	Fire Pump Pressure Low
77	81	-	0	Exhaust Back Pressure High
77	81	-	1	Exhaust Back Pressure Low
77	81	-	3	Exhaust Back Pressure Sensor Voltage High
77	81	-	4	Exhaust Back Pressure Sensor Voltage Low
77	81	-	12	Exhaust Back Pressure at Rampdown Threshold
77	95	-	1	Fuel Filter Differential Pressure Low
77	99	-	1	Oil Filter Differential Pressure Low
77	100	-	0	Engine Oil Pressure High
77	102	-	1	Turbo Boost Pressure Low
77	105	-	1	Inlet Manifold Temperature Low
77	107	-	1	Air filter Restriction Pressure Low
77	108	-	0	Barometric Pressure High
77	108	-	1	Barometric Pressure Low
77	109	-	0	Coolant Pressure High
77	110	-	1	Coolant Temperature Low
77	111	-	0	Coolant Level High
77	-	151	11	Service Now Lamp Fault Expiration
77	171	-	0	Ambient Air Temperature High
77	171	-	1	Ambient Air Temperature Low
77	172	-	1	Air Inlet Temperature Low
77	174	-	0	Fuel Temperature High
77	174	-	1	Fuel Temperature Low
77	175	-	1	Engine Oil Temperature Low
77	177	-	0	Transmission Oil Temperature High
77	177	-	1	Transmission Oil Temperature Low
77	177	-	3	Transmission Oil Temperature Failed High
77	177	-	4	Transmission Oil Temperature Failed Low
77	-	151	11	Service Now Lamp Fault Expiration
78	86	-	14	Cruise Control/Adaptive Cruise Control Fault
81	98	-	3	Oil Level Sensor Input Voltage High
81	173	-	3	Exhaust Temperature Sensor Input Voltage High
81	355	-	3	Engine Oil Life Sensor Circuit Failed High
81	411	-	3	EGR Delta Pressure Circuit Failed High
81	412	-	3	EGR Temperature Circuit Failed High

DDC Code # (Flashed)	PID	SID	FMI	Description
81	355	-	3	Engine Oil Life Sensor Circuit Failed High
82	98	-	4	Oil Level Sensor Input Voltage Low
82	101	-	4	Crankcase Pressure Sensor Input Voltage Low
82	153	-	4	Extended Crankcase Pressure Input Voltage Low
82	173	-	4	Exhaust Temperature Sensor Input Voltage Low
82	355	-	4	Engine Oil Life Sensor Circuit Failed Low
82	411	-	4	EGR Delta Pressure Circuit Failed low
82	412	-	4	EGR Temperature Circuit Failed Low
83	73	-	0	Aux. Pump Pressure High
83	98	-	0	Oil Level High
83	101	-	0	Crankcase Pressure High
83	153	-	0	Extended Crankcase Pressure High
83	173	-	0	Exhaust Temperature High
83	355	-	9	Coolant In Oil Detected
83	355	-	14	Change Oil Now
83	411	-	0	EGR Delta Pressure High
83	412	-	0	EGR Temperature High
84	98	-	1	Oil Level Low
84	355	-	1	Change Oil Soon
85	190	-	0	Engine Overspeed
85	190	-	14	Engine Overspeed Signal
86	73	-	3	Aux. Pump Pressure Sensor Input Voltage High
86	108	-	3	Barometric Pressure Sensor Input Voltage High
87	73	-	4	Pump Pressure Sensor Input Voltage Low
87	108	-	4	Barometric Pressure Sensor Input Voltage Low
89	95	-	0	Fuel Filter Restriction High
89	111	-	12	Maintenance Alert Coolant Level Fault
-	-	240	2	ECU Checksum Incorrect
-	-	240	13	ECU Checksum Incorrect
-	-	253	2	Calibration Checksum Incorrect
-	-	253	9	Calibration Checks Invalid
-	-	253	13	Calibration Versions Invalid
-	-	254	0	External RAM Failed
-	-	254	1	Internal RAM Failed
-	-	254	6	Module Forced To Boot Mode
-	-	254	12	Boot Code Checksum INcorrect

**Table 9-1 Flash Codes, SAE Codes, Descriptions**

## LOGIC CODES (MECHANICAL FAILURES)

Logic codes indicate the detection of mechanical failures by the DDEC V system. The response will be a Flash Code.

### Diagnosing Flash Code 13

*Failure Mode:* **SID 146, FMI 6**

*Indicates:* **EGR Valve Current is too high.**

*Response:* Perform the following steps if the EGR Valve current is too high.

1. Check for a short circuit.
2. Disconnect the harness connector from the actuator control valve coil.
3. Measure the coil resistance between pins A and B. Table 9-2 and see Figure 9-1.
  - [a] If the coil resistance is too low replace the actuator assembly.
  - [b] If the coil resistance is okay, go to step 4.
4. Disconnect engine harness at ECU and at coil and measure resistance across the two pin connector pins.
  - [a] If resistance is less than 100  $\Omega$ , the two wires are shorted to each other.
  - [b] If the resistance is greater than 100  $\Omega$ , try a test ECU or contact Detroit Diesel Technical Service.

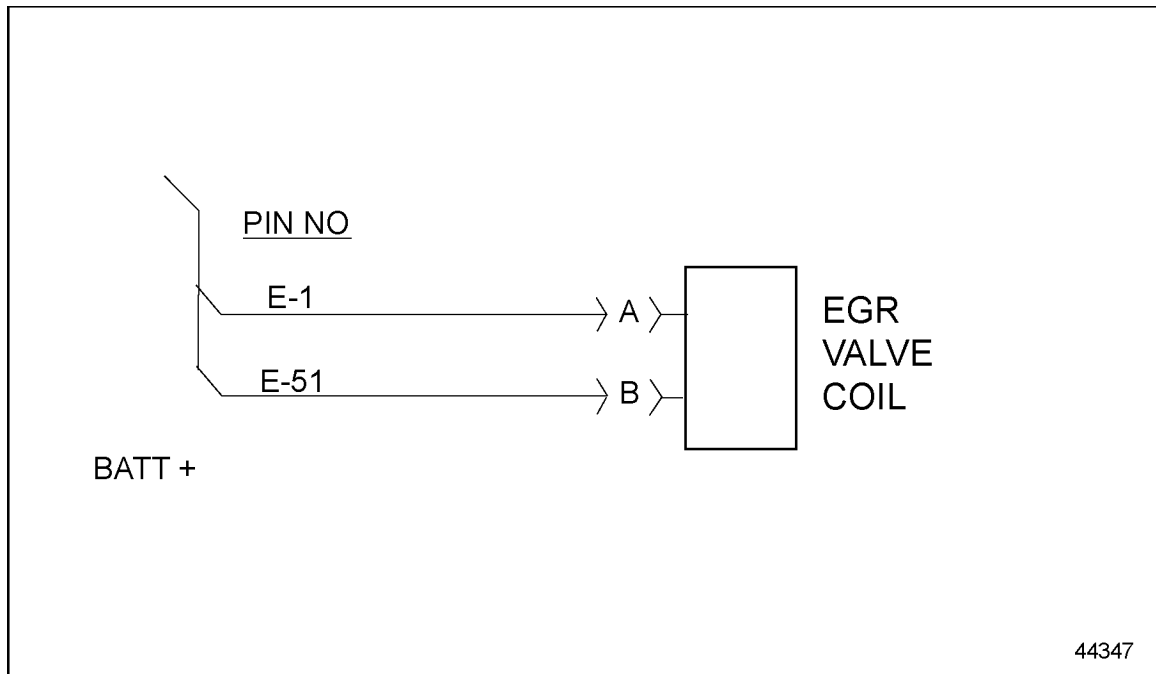

**Figure 9-1 EGR Valve Coil Wiring**

Coil Temperature °C	Coil Temperature °F	Allowed Ranges (ohms)
22	71	3.4 - 4.2
50	122	3.7 - 4.6
100	212	4.4 - 5.4

**Table 9-2 Ranges Allowed (Ohms)**

*Possible Causes:*

- Wires shorted together.**
- Positive wire shorted to ground.**
- Low resistance in the solenoid.**

**NOTE:**

This symptom may be improved with reprogramming.

Reprogram the ECU if the ECU has not been reprogrammed since the dates listed below.

- 12 L — 02-23-04
- 14 L — 03-08-04

**NOTE:**

There is an update program for the DDEC V troubleshooting in 6.0 DDDL.

1. 
  - [a] 12L engine.
  - [b] If the software level is below XX on a 14L engine.

## **EGR Valve Current**

*Failure Mode:* **SID 146, FMI 5 & 6**

**EGR Valve Current is too low (FMI 5) or EGR Valve Current is too high (FMI 6)**

The CEL (AWL) will be illuminated and the engine will operate in boost mode.





## 10 DDEC V TESTING

As of April 1, 2004 all current known 2004 DDEC V issues can be resolved by reprogramming the ECU.

- Flash Code 13 and 16 — EGR Valve Current
- Cold engine/Idle Smoke
- Misfire — Shutter at Road Speed



## APPENDIX A: LIST OF ACRONYMS

AKA	Also Known As
CEL	Check Engine Light
CAC	Charge Air Cooler
Delta P	Differential Pressure
DDEC	Detroit Diesel Electronic Controls
DPS	Delta P Sensor
DTC	Diagnostic Trouble Code
ECM	Electronic Control Module (aka ECU)
ECU	Electronic Control Unit (aka ECM)
EGR	Exhaust Gas Recirculation
ESC	Abbreviation on a Computer Keyboard for 'Escape'
FMI	Failure Mode Identifier
KRPM	RPM X 1000
kPa	Kilopascals
PID	Parameter Identification
PSI	Pounds per Square Inch
PWM	Pulse Width Modulation
RHS	Relative Humidity Sensor
RPM	Revolutions per Minute
SAE	Society of Automotive Engineers
SEL	Stop Engine Light
SID	System Identification
S Pipe	Pipe Shaped Like an 'S'
VGT	Variable Geometry Turbocharger (aka VNT)
VNT	Variable Nozzle Turbocharger (aka VGT)
VOM	Volt Ohm Meter
VPOD	Variable Pressure Output (Orifice) Device
<	Less Than
>	Greater Than



## APPENDIX B: DDEC IV WIRING SCHEMATICS

- DDEC IV Vehicle Harness — see Figure B-1.
- DDEC IV Engine Wiring Diagram — See Figure B-2.
- DDEC V Engine Harness — see Figure B-3.
- DDEC V Vehicle Interface Harness — see Figure B-4.



# SERIES 60 DDEC IV MY2003 EGR VEHICLE INTERFACE HARNESS

# OEM RESPONSIBILITY

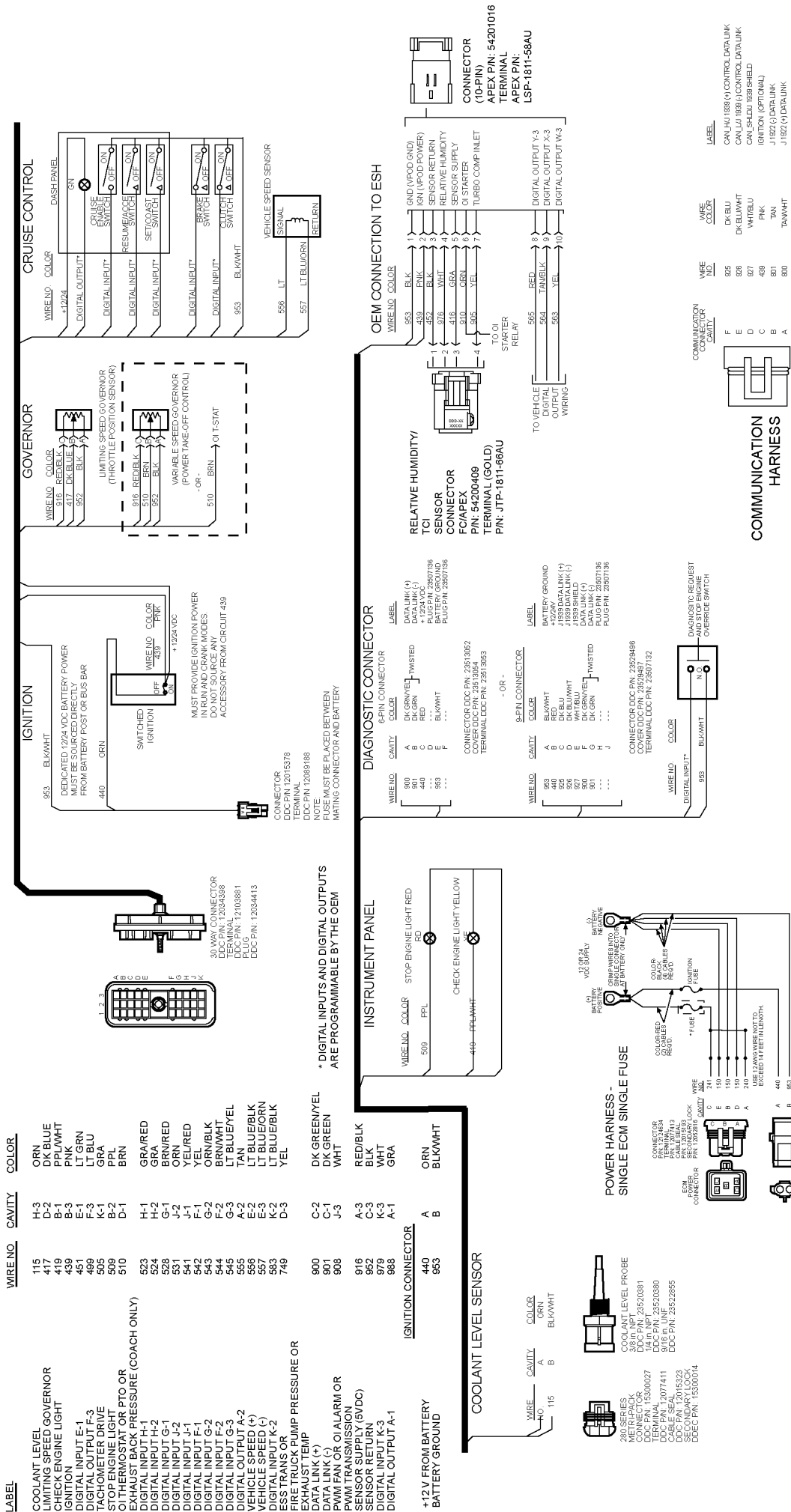



# DDEC IV WIRING DIAGRAM

## DDC RESPONSIBILITY

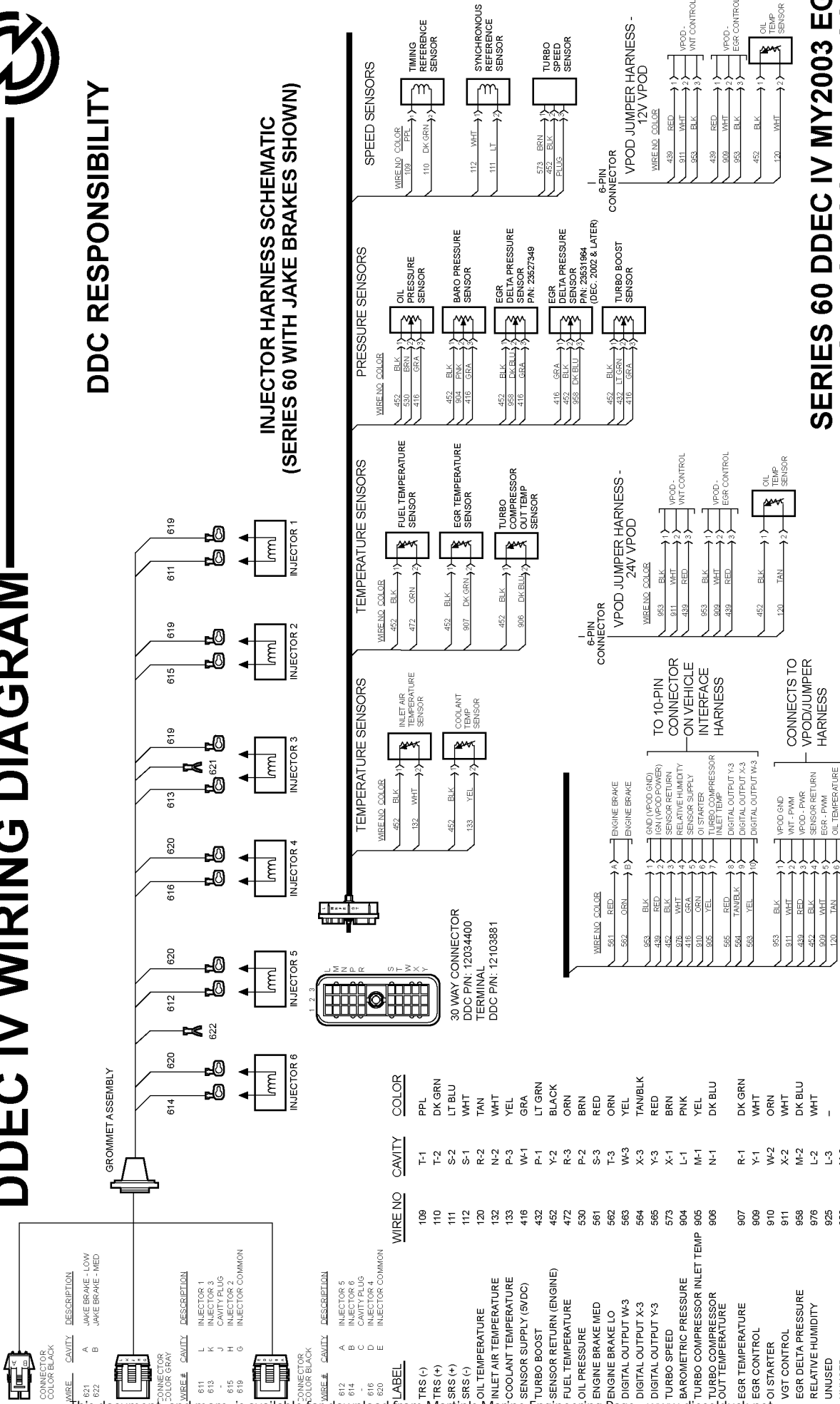

## SERIES 60 DDEC IV MY2003 EGR ENGINE SENSOR HARNESS





# DDEC V WIRING DIAGRAM

## DDC RESPONSIBILITY

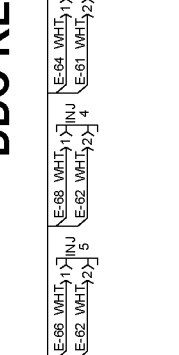
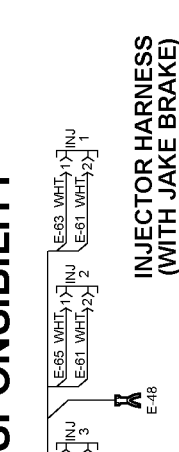

PIN NO.	COLOR	DESCRIPTION
1	WHT	INU COMMON 1,2,3
2	WHT	INU COMMON 4,5,6
3	WHT	INU 1
4	WHT	INU 3
5	WHT	INU 2
6	WHT	INU 5
7	WHT	INU 6
8	WHT	INU 4
9	WHT	JAKE 1,2,3
10	WHT	JAKE 4,5,6

PIN NO.	WIRE COLOR	DESCRIPTION
E-1	BLK	EGR HYDRAULIC VALVE CONTROL
E-2	WHT	AIR TEMP
E-3	BLK	WNT VPOD CONTROL
E-4	YEL	COOLANT TEMP
E-5	TAN	OIL TEMP
E-6	ORN	FUEL TEMP
E-7	DK GRN	EGR TEMP
E-8	GRA	SENSOR SUPPLY
E-9	BLK	SENSOR RETURN
E-10	YLK	REL RESTRICTION - MAS
E-11	PURPLE	TRS
E-12	DK GRN	SRS+
E-13	LT BLU	SRS-
E-14	WHT	OIL LEVEL - MAS
E-15	DK GRN	COMPRESSOR TEMP OUT
E-16	DK BLU	SPARE
E-17	DK GRN	SPARE
E-18	DK GRN	SPARE
E-19	WHT	SPARE
E-20	DK GRN	SPARE
E-21	DK GRN	SPARE
E-22	DK BLU	SPARE
E-23	DK GRN	SPARE
E-24	DK GRN	SPARE
E-25	DK GRN	SPARE
E-26	DK GRN	SPARE
E-27	DK GRN	SPARE
E-28	DK GRN	SPARE
E-29	DK GRN	SPARE
E-30	DK GRN	SPARE
E-31	DK GRN	SPARE
E-32	DK GRN	SPARE
E-33	DK GRN	SPARE
E-34	DK GRN	SPARE
E-35	DK GRN	SPARE
E-36	DK GRN	SPARE
E-37	DK GRN	SPARE
E-38	DK GRN	SPARE
E-39	DK GRN	SPARE
E-40	DK GRN	SPARE
E-41	DK GRN	SPARE
E-42	DK GRN	SPARE
E-43	DK GRN	SPARE
E-44	DK GRN	SPARE
E-45	DK GRN	SPARE
E-46	DK GRN	SPARE
E-47	DK GRN	SPARE
E-48	DK GRN	SPARE
E-49	DK GRN	SPARE
E-50	DK GRN	SPARE
E-51	DK GRN	SPARE
E-52	DK GRN	SPARE
E-53	DK GRN	SPARE
E-54	DK GRN	SPARE
E-55	DK GRN	SPARE
E-56	DK GRN	SPARE
E-57	DK GRN	SPARE
E-58	DK GRN	SPARE
E-59	DK GRN	SPARE
E-60	DK GRN	SPARE
E-61	DK GRN	SPARE
E-62	DK GRN	SPARE
E-63	DK GRN	SPARE
E-64	DK GRN	SPARE
E-65	DK GRN	SPARE
E-66	DK GRN	SPARE
E-67	DK GRN	SPARE
E-68	DK GRN	SPARE

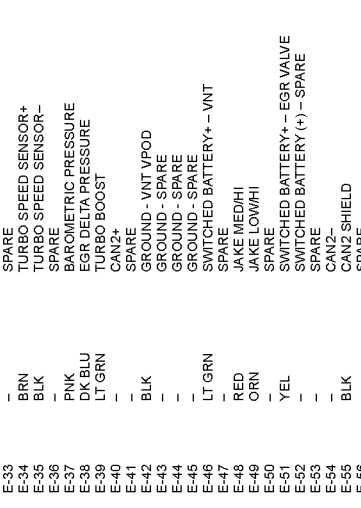
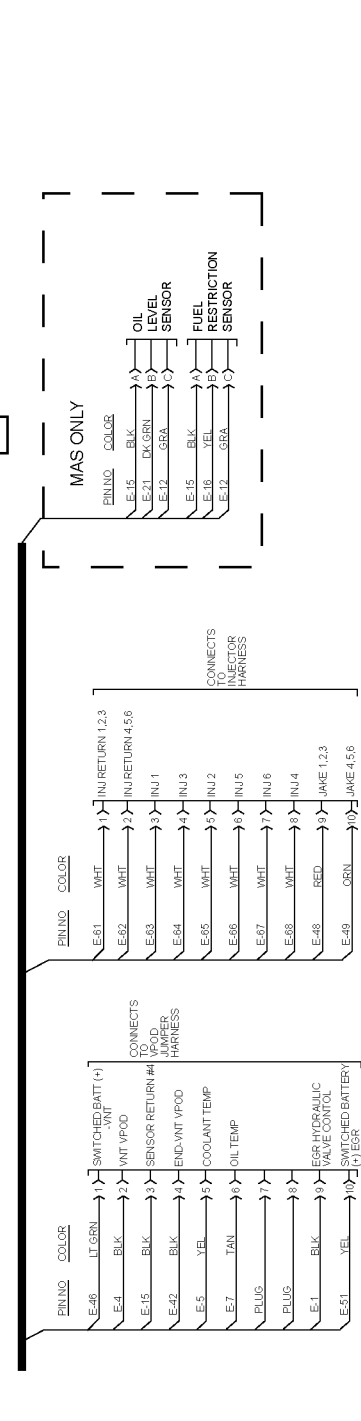
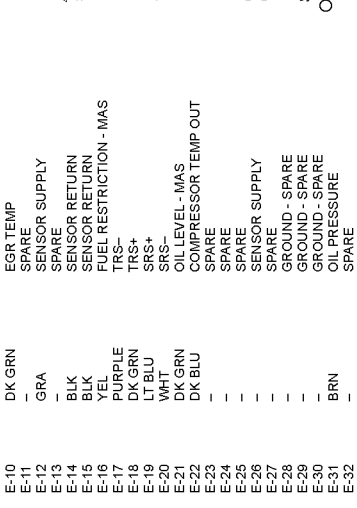
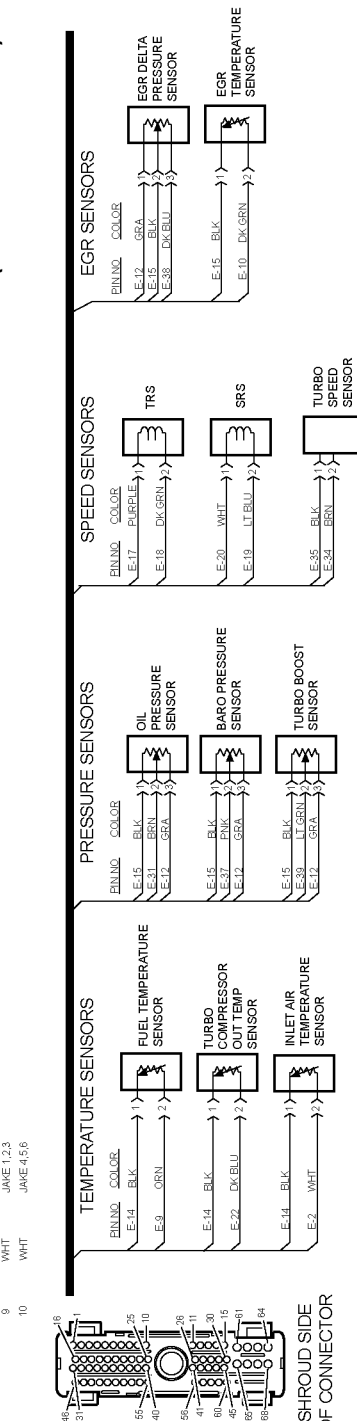

PIN NO.	COLOR	DESCRIPTION
E-1	LT GRN	SWITCHED BATT (+)
E-2	BLK	WNT VPOD
E-3	BLK	SENSOR RETURN #4
E-4	BLK	END-VNT VPOD
E-5	YEL	COOLANT TEMP
E-6	TAN	OIL TEMP
E-7	TAN	OIL TEMP
E-8	PLUG	PLUG
E-9	PLUG	PLUG
E-10	PLUG	PLUG
E-11	PLUG	PLUG
E-12	PLUG	PLUG
E-13	PLUG	PLUG
E-14	PLUG	PLUG
E-15	BLK	COOLANT TEMP SENSOR
E-16	YEL	OIL TEMPERATURE SENSOR
E-17	GRN	JAKE 1,2,3
E-18	GRN	JAKE 4,5,6
E-19	GRN	JAKE 1,2,3
E-20	GRN	JAKE 4,5,6
E-21	GRN	JAKE 1,2,3
E-22	GRN	JAKE 4,5,6
E-23	GRN	JAKE 1,2,3
E-24	GRN	JAKE 4,5,6
E-25	GRN	JAKE 1,2,3
E-26	GRN	JAKE 4,5,6
E-27	GRN	JAKE 1,2,3
E-28	GRN	JAKE 4,5,6
E-29	GRN	JAKE 1,2,3
E-30	GRN	JAKE 4,5,6
E-31	GRN	JAKE 1,2,3
E-32	GRN	JAKE 4,5,6
E-33	GRN	JAKE 1,2,3
E-34	GRN	JAKE 4,5,6
E-35	GRN	JAKE 1,2,3
E-36	GRN	JAKE 4,5,6
E-37	GRN	JAKE 1,2,3
E-38	GRN	JAKE 4,5,6
E-39	GRN	JAKE 1,2,3
E-40	GRN	JAKE 4,5,6
E-41	GRN	JAKE 1,2,3
E-42	GRN	JAKE 4,5,6
E-43	GRN	JAKE 1,2,3
E-44	GRN	JAKE 4,5,6
E-45	GRN	JAKE 1,2,3
E-46	GRN	JAKE 4,5,6
E-47	GRN	JAKE 1,2,3
E-48	GRN	JAKE 4,5,6
E-49	GRN	JAKE 1,2,3
E-50	GRN	JAKE 4,5,6
E-51	GRN	JAKE 1,2,3
E-52	GRN	JAKE 4,5,6
E-53	GRN	JAKE 1,2,3
E-54	GRN	JAKE 4,5,6
E-55	GRN	JAKE 1,2,3
E-56	GRN	JAKE 4,5,6
E-57	GRN	JAKE 1,2,3
E-58	GRN	JAKE 4,5,6
E-59	GRN	JAKE 1,2,3
E-60	GRN	JAKE 4,5,6
E-61	GRN	JAKE 1,2,3
E-62	GRN	JAKE 4,5,6
E-63	GRN	JAKE 1,2,3
E-64	GRN	JAKE 4,5,6
E-65	GRN	JAKE 1,2,3
E-66	GRN	JAKE 4,5,6
E-67	GRN	JAKE 1,2,3
E-68	GRN	JAKE 4,5,6

# SERIES 60 DDEC V EGR ENGINE HARNESS

PIN NO.	COLOR	DESCRIPTION
1	LT GRN	SWITCHED BATT (+)
2	BLK	WNT VPOD CTRL
3	BLK	SENSOR RETURN #4
4	BLK	END-VNT VPOD
5	YEL	COOLANT TEMP
6	TAN	OIL TEMP
7	PLUG	PLUG
8	PLUG	PLUG
9	BLK	EGR HYDRAULIC VALVE CTRL
10	YEL	SWITCHED BATT (+) - EGR

Information subject to change without notice. (Rev. 11/03)  
 14821 0311 Copyright © 2003 DETROIT DIESEL CORPORATION.

CAVITY	LABEL
V-1	AMBER WARNING LAMP
V-2	RED STOP LAMP
V-3	SERVICE BRAKE RELEASED
V-4	FAN CONTROL #1
V-5	DIGITAL OUTPUT
V-6	DIGITAL OUTPUT
V-7	VEHICLE PWR SHUTDOWN
V-8	RESUME/ACCEL
V-9	CRUISE ENABLE
V-10	CLUTCH RELEASED
V-11	SENSOR SUPPLY #1
V-12	SENSOR SUPPLY #2
V-13	THROTTLE POSITION
V-14	VSS
V-15	IGNITION
V-16	IDLE VALIDATION
V-17	VEHICLE SPEED SENSOR (+)
V-18	VEHICLE SPEED SENSOR (-)
V-19	NO CONNECTION
V-20	NO CONNECTION
V-21	NO CONNECTION
V-22	AIR FILTER RESTRICTION
V-23	EXHAUST TEMPERATURE
V-24	SEC/DIAG REQUEST
V-25	A/C STATUS
V-26	ANALOG INPUT - 1.5KG PULLUP
V-27	TURBO COMPRESSOR IN TEMP
V-28	NO CONNECTION
V-29	EXHAUST BACK PRESSURE OR FIRE TRUCK PUMP PRESSURE
V-30	TACHOMETER
V-31	FREQUENCY - SPARE
V-32	FREQUENCY - SPARE
V-33	NO CONNECTION
V-34	NO CONNECTION
V-35	NO CONNECTION
V-36	NO CONNECTION
V-37	ADD COOLANT LEVEL
V-38	COOLANT LEVEL - SHUTDOWN
V-39	ENGINE BRAKE LOW
V-40	OI ALARM
V-41	AUX SHUTDOWN #1
V-42	OI THERMOSTAT
V-43	J 1939 DL (+)
V-44	J 1939 DL SHIELD
V-45	NO CONNECTION
V-46	PWM OUTPUT
V-47	SET/COAST
V-48	ANALOG INPUT - 1.5KG PULLUP
V-49	FAN CONTROL OVERRIDE
V-50	PARK BRAKE
V-51	ENG BRAKE MED
V-52	PWM OUTPUT
V-53	ETHER START
V-54	OI STARTER
V-55	OI ACTIVE LAMP
V-56	J 1587 +
V-57	J 1587 -
V-58	J 1939 DL (-)
V-59	SENSOR RETURN #2
V-60	SENSOR RETURN #1
V-61	+12V / +24V
V-62	+12V / +24V
V-63	BATTERY GROUND
V-64	BATTERY GROUND
V-65	+12V / +24V
V-66	+12V / +24V
V-67	BATTERY GROUND
V-68	BATTERY GROUND

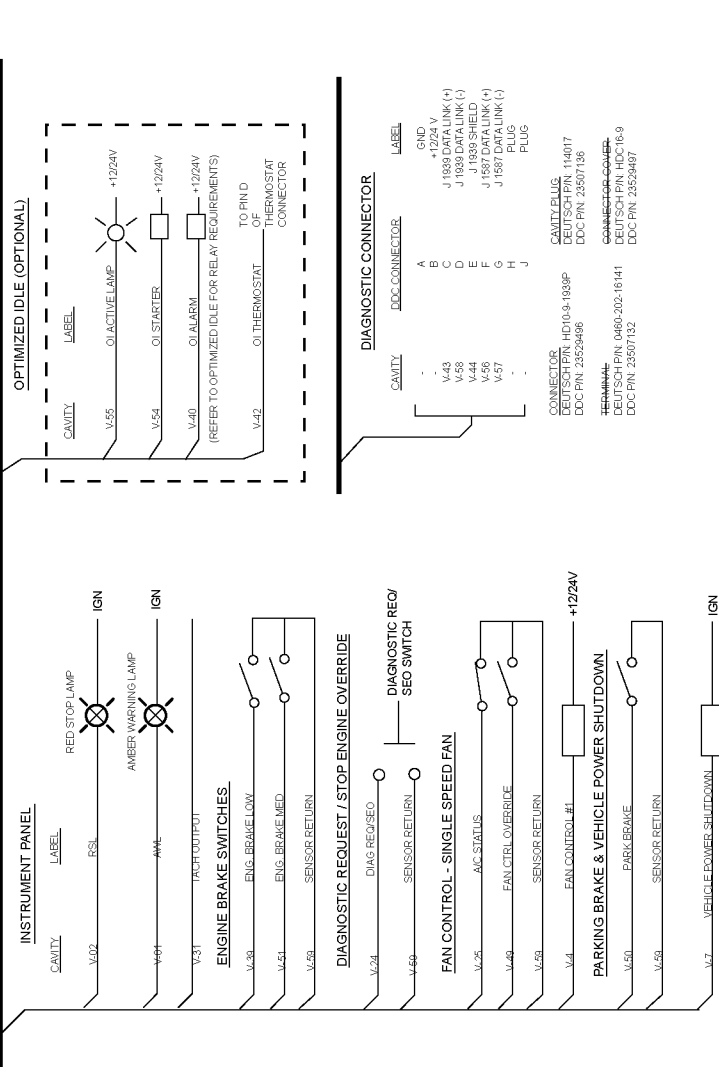
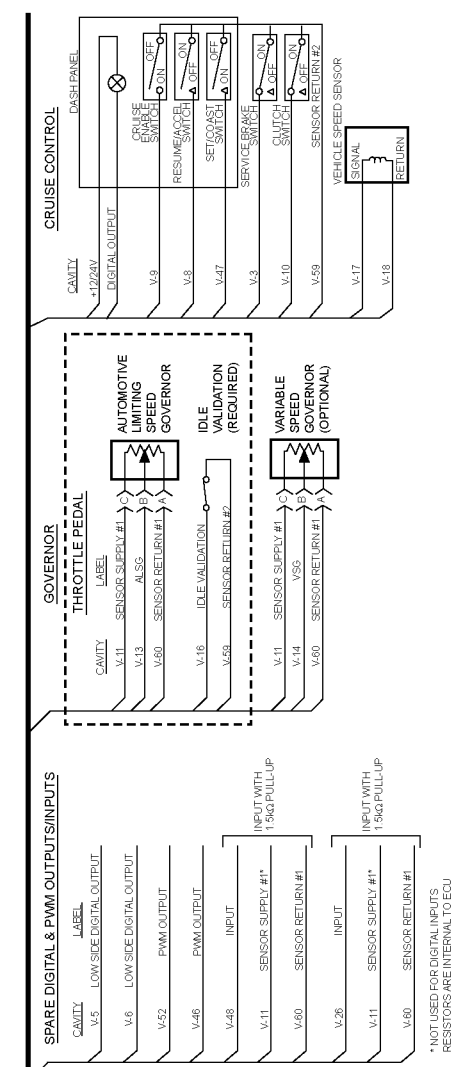
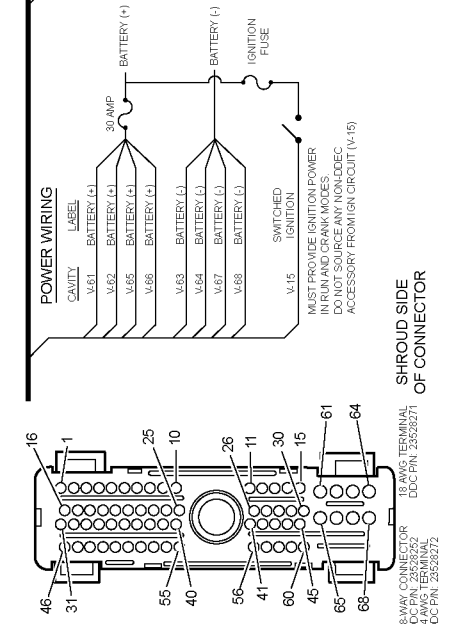

# DDEC V VEHICLE INTERFACE HARNESS

## APPENDIX C: ENGINE DIAGNOSTIC QUESTIONNAIRE

- Engine Diagnostic Questionnaire



**Engine Diagnostic Questionnaire**

RO # \_\_\_\_\_

Customer Name: \_\_\_\_\_

Contact Person: \_\_\_\_\_

**LOW POWER/POOR FUEL ECONOMY:**

Does check engine light come on? Yes \_\_\_\_\_ No \_\_\_\_\_

Does the engine miss, run rough, hard starting? Miss Run Rough Hard Starting

Power Loss sudden or has decreased with time? Sudden Decreased with time

Excessive engine exhaust smoke (see #3)? Yes \_\_\_\_\_ No \_\_\_\_\_

If yes, what color? Black Blue White

Heard any unusual engine noise? Yes \_\_\_\_\_ No \_\_\_\_\_

Power loss occurs on Foot Cruise Both

Have injectors been replaced recently? Yes \_\_\_\_\_ No \_\_\_\_\_

When was last tune up? Mileage \_\_\_\_\_ Date \_\_\_\_\_

Comments: \_\_\_\_\_

**ANY INTERMITTENT PROBLEMS:**

Last time it happened: \_\_\_\_\_

Does the check engine light come on? Yes \_\_\_\_\_ No \_\_\_\_\_

Does the problem occur only in damp or rainy conditions? Yes \_\_\_\_\_ No \_\_\_\_\_

When the vehicle hits a bump or rough road? Yes \_\_\_\_\_ No \_\_\_\_\_

Does the engine: Miss Drop to idle Quit running

Gauge Sweep Hard Starting

Comments: \_\_\_\_\_

e.g. Does the driver do anything to correct the problem? \_\_\_\_\_

**SMOKING:**

Where is the smoke coming from? \_\_\_\_\_

What color is the smoke? Blue Black White BI/White

When does it smoke? Start-up Cold Eng. Hot Eng. U.Load

Have you noticed any oil consumption? Yes \_\_\_\_\_ No \_\_\_\_\_

Have you noticed a miss in the engine? Yes \_\_\_\_\_ No \_\_\_\_\_

Was the smoke intermittent? Start all at once? Been getting worse over time?

Comments: \_\_\_\_\_

**COOLANT LOSS**

Has the oil level risen? Yes \_\_\_\_\_ No \_\_\_\_\_

Have you noticed any coolant leaks? Yes \_\_\_\_\_ No \_\_\_\_\_

How often do you add coolant? \_\_\_\_\_ How Much? \_\_\_\_\_

What kind of coolant do you use? \_\_\_\_\_

What kind of inhibitor do you use? \_\_\_\_\_

Comments: \_\_\_\_\_

**OIL CONSUMPTION:**

How much oil are you adding? \_\_\_\_\_ How often (miles)? \_\_\_\_\_

Have you noticed any oil leaks? Yes \_\_\_\_\_ No \_\_\_\_\_

Have you noticed any smoke out the exhaust? Yes \_\_\_\_\_ No \_\_\_\_\_

At Idle Light or no load Heavy load

How often do you change oil? \_\_\_\_\_ What Brand? \_\_\_\_\_

Have you changed brands recently? Yes \_\_\_\_\_ No \_\_\_\_\_

How & when do you check your oil? \_\_\_\_\_

Comments: \_\_\_\_\_



## APPENDIX D: SERVICE INFORMATION LETTERS

- Service Information Letter 03 TS-23 (View One of Two) — see Figure D-2.
- Service Information Letter 03 TS-23 (View Two of Two) — see Figure D-3.
- Service Information Letter (View One of Four) — see Figure D-4.
- Service Information Letter (View Two of Four) — see Figure D-5.
- Service Information Letter (View Three of Four) — see Figure D-6.
- Service Information Letter (View Four of Four) — see Figure D-7.
- Service Information Letter (View One of One) — see Figure D-8.







**NO.: 03 TS - 23**  
May 28, 2003

TO: All Distributors, Branches and Dealers

ATTN: Service Manager, Class of 2003 Representative

FROM: M. F. Kubiak

SUBJECT: **S60 EGR De-rating Due to Higher Temperatures – Air and Coolant**

DDEC's engine protection operation is designed to provide protection to the engine and vehicle from damage due to high temperatures, low pressure or low levels.

From its initial release in the mid 1980's the technology DDC uses has remained for the most part unchanged. This letter is intended to introduce you to technology enhancements designed for 2003 engines and beyond and the differences you must understand.

Current on highway Series 60 engines utilize Exhaust Gas Recirculation (EGR) technology. The introduction of EGR into the intake system increases the temperature of air in the intake system and adds heat to the coolant. Under some conditions, engine fan operation is used to keep coolant and charge air temperatures within a recommended range. Under certain more demanding operating conditions, (e.g. high ambient, high loads, high altitudes etc) vehicle cooling system components alone may not be able to respond to the rapidly generated heat. This can be especially true when operating an EGR equipped vehicle on a chassis dynamometer since normal ram air for cooling is absent.

If the cooling system (fan, radiator, charge air cooler, etc.) is not able to maintain proper temperatures of the air, and coolant, the DDEC system is programmed to reduce fueling (power) for a short time to reduce air and coolant temperatures. A small amount of reduction is done within the engine calibration without any notification to the operator. Once the affected temperature (e.g. coolant or air) returns to normal levels, the maximum fueling is restored.

The DDEC system will store an information code indicating that this event occurred. No corrective action is required as this action is intended and is designed to reduce operating temperatures without a noticeable affect on vehicle performance. It is possible that the driver may notice a slight change in the engine's sound during the time the derate occurs.

These information codes (FMI 14) will not illuminate a check or stop engine light, nor broadcast a message to the dash. These information codes will only be seen when viewing codes with a diagnostic tool, or in data downloaded via DDEC Reports. Codes that should be of concern are those with a failure mode identifier (FMI) of 0 (High). FMI 0 codes will illuminate check and/or stop engine lights alerting the user to a problem that needs attention. Today three temperatures are monitored for use in derating strategies.

Detroit Diesel Corporation 13400 Outer Drive, West / Detroit, Michigan 48239-4001 / Telephone: 313-592-5000

DA 1

*An Equal Opportunity Employer*



Coolant temperature:

- Flash code 44
- PID 110 FMI 14 De-rate for temperature control
- PID 110 FMI 0 Above limits – attention required

• Intake Manifold temperature:

- Flash Code 44
- PID 105 FMI 14 – Derate for temperature control
- PID 105 FMI 0 - Above limits– attention required

• Turbocharger Compressor Outlet (TCO) temperature :

- Flash code 49
- PID 404 FMI 14 – De-rate for temperature control
- PID 404 FMI 0 - Above limits– attention required

**Again, the FMI 14 is for information only and is not indicative of a fault requiring any attention.**

In the event that high heat load conditions are so severe that the derate temperature control strategy cannot prevent continued temperature rise, DDEC's engine protection will take over and illuminate the Check or Stop engine light and proceed to the level of protection programmed (shutdown, warning). Operation of this protection is detailed in the following graph.

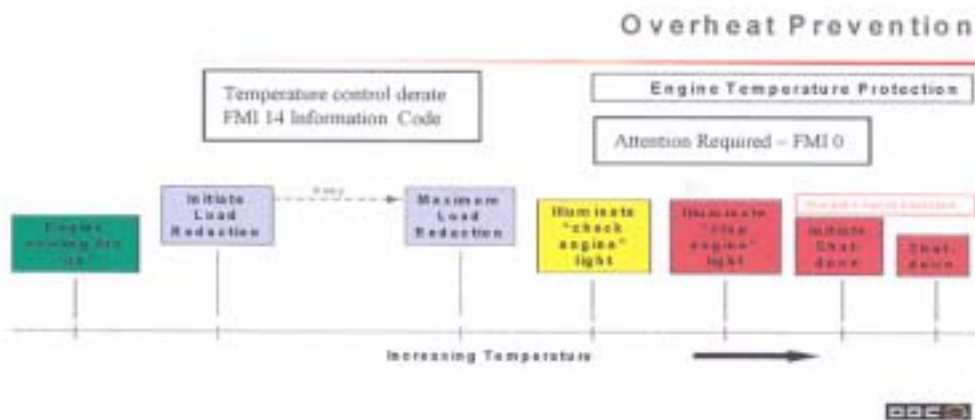

1/23/02

Confidential Business Information

Temperature limits are not published for this example. Certain parameters may not initiate a shutdown and the graph is used to simply illustrate the logic used to provide proper engine and vehicle protection.

M. F. Kubiak  
Customer Assurance



**NO.: 03 TS - 44**  
September 10, 2003

**TO:** All Distributors & Branches – U.S. & Canada  
**ATTN.:** Service Manager/Parts Manager/Dealer Representative  
**FROM:** Nahum Veach  
**SUBJECT:** **Series 60 EGR Turbocharger Service Parts and VNT Actuator Calibration**

The following service parts have been released to service the Series 60 EGR Turbocharger:

23505493	Compressor V-band kit
23531930	VNT actuator
23531929	Actuator bracket
23530252	Turbo speed sensor
23531926	Crank pin kit

For warranty repairs, it is now required to replace these components when found to be defective instead of replacing the turbocharger assembly.

When troubleshooting the EGR system, it is now required that the technician check the VNT actuator calibration. The following procedure describes actuator calibration and should be used in conjunction with DDEC III/IV Single ECM Troubleshooting Guide, Section 10.18:

1. Disconnect the air hose to the VNT actuator.
2. Connect a regulated air supply to the VNT actuator fitting.
3. Slowly adjust air pressure from 0 – 482 kPa (0 – 71 psig) and watch actuator rod travel. Actuator rod should not bind and travel should be smooth.
  - a. if air is heard escaping from the actuator, indicating a blown diaphragm, replace the actuator assembly
  - b. if actuator rod does not move when air pressure is applied, disconnect the actuator arm from the crank pin and rotate the crank.
    - i. if crank is seized, replace turbocharger assembly.
    - ii. if crank rotates freely, then the actuator is seized. Replace the actuator assembly.
  - c. if the rod end touches the minimum stop screw between 475 – 489 kPa (69.0 - 71.0 psig), then the actuator is calibrated correctly. Continue with the troubleshooting process.



- d. if the rod end does not touch the minimum stop screw between 475 – 489 kPa (69.0 – 71.0 psig), actuator calibration is necessary.

### **Series 60 VNT Actuator Removal and Replacement Procedure**

#### **Caution**

1. **Under no conditions should the actuator canister be opened** in an attempt to rebuild. There is a powerful coil spring compressed inside the can to a load of 150 – 500 lbs., which can cause physical harm. The actuators are serviced as an assembly and internal parts are not available.
2. Exercise caution in both handling and in positioning the turbocharger assembly on the workbench to avoid damage to external parts. Be sure the speed sensor electrical connector/lead wire does not become trapped under the turbocharger. Avoid any mechanical damage to the actuator canisters and air pressure fittings.
3. The minimum crank stop (stop screw and lock nut) has been preset at the factory and sealed with a special paint. Under no circumstances should this stop be readjusted in the field. If tampered with, all warranties, expressed and implied, are void and damage to the engine could occur.

#### **VNT Actuator Removal (Refer to Figure 1)**

1. Locally clean the area around actuator and VNT external linkage to remove oily grease, dirt, or paint deposits.
2. Carefully remove the actuator rod end retaining ring.
3. Pressurize the actuator to 267 kPa (40 psig) and remove the clevis pin from the external crank.
4. Remove pressure from the actuator.
5. Loosen and remove the three lock nuts that fasten the actuator to the bracket and remove the actuator.
6. Using a pocket scale, measure and record the approximate distance from the rod end to the base of the actuator can (See Figure 2).

#### **VNT Actuator Installation and Calibration**

1. Assemble the replacement actuator. Ensure that the rod end and actuator rod are threaded into the adjuster body equal distances. Turn the adjuster body to achieve the same value recorded in step 6 above.
2. Assemble the replacement actuator to the bracket and torque nuts to 6.2-7.9 N-m (55 – 70 in-lbs).
3. Attach the air hose from the pressure regulator to the actuator fitting. Apply approximately 267 kPa (40 psig) to the actuator.
4. Rotate the clevis and align the clevis and rod end holes and insert pin.
5. Carefully reinstall the retaining clip.
6. Slowly increase the pressure to the actuator to  $441 \pm 3.5$  kPa ( $64 \pm 0.5$  psig). If pressure reaches above 444.5 kPa (64.5 psig), reduce pressure to 276 kPa (40 psig) and repeat this step. Allow the pressure to stabilize for 10 seconds. The actuator rod should extend and be at, or near, the minimum stop screw.
7. Rotate the ***adjuster body*** (see Figure 1) until a 0.004 inch  $\pm$  0.001 (0.10  $\pm$  .0250 mm) gap is achieved between the stop screw and clevis. Without allowing the adjuster body to rotate, tighten the lock nuts to 6.2 – 7.9 N-m (55 – 70 in-lbs).

8. Cycle pressure from 0 psig to 441 kPa (64 psig) and check for proper operation. Set pressure to 276 kPa (40 psig) and slowly increase pressure to 441 kPa (64 psig) and recheck the gap between the stop screw and the clevis. You should be able to fit a feeler gage of 0.10mm (0.004 inches) between them. If the gap is not between .003 - .005 inches, repeat process in step 7.
9. Cycle pressure a few times from 0 to 441 kPa (64 psig) until satisfied that the rod position at minimum stop has been satisfactorily set and the actuator is stroking from one stop to the other.

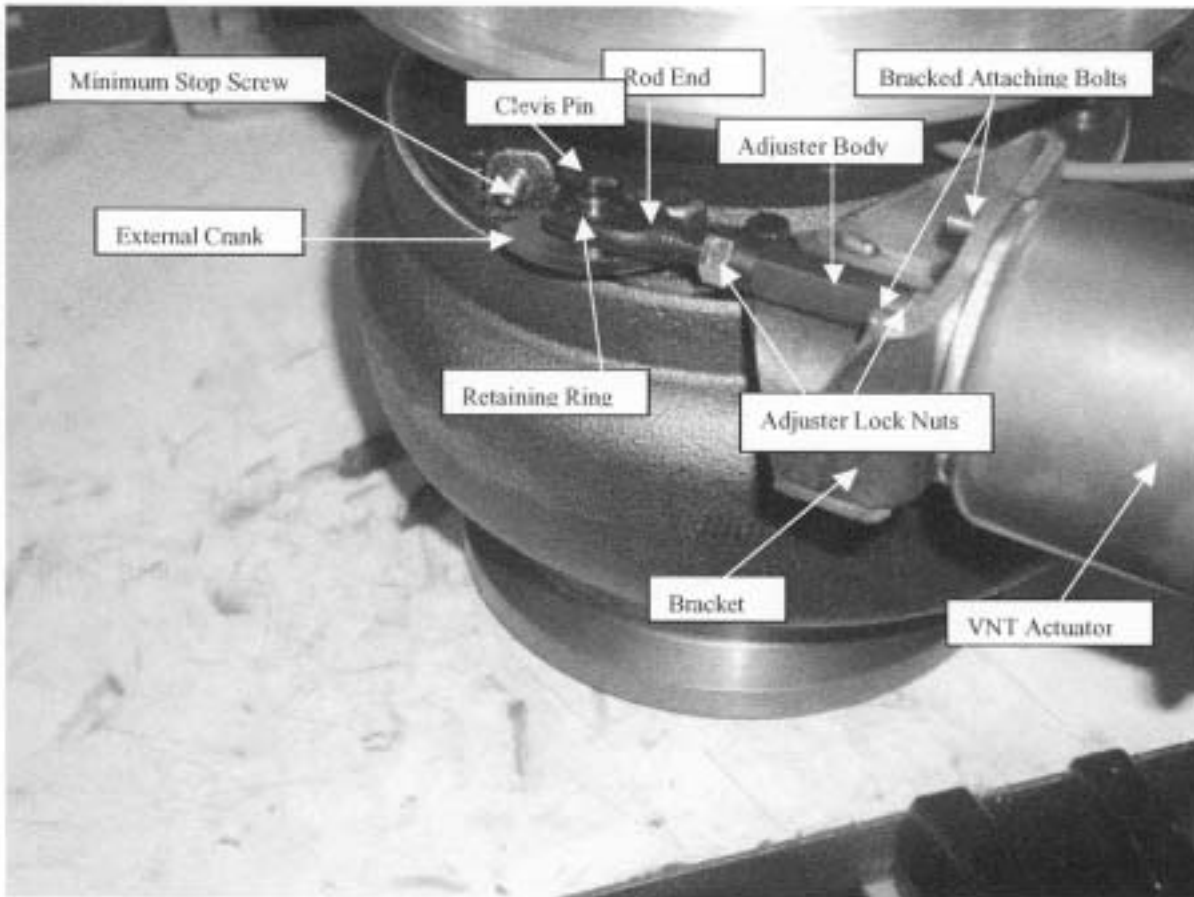

Figure 1

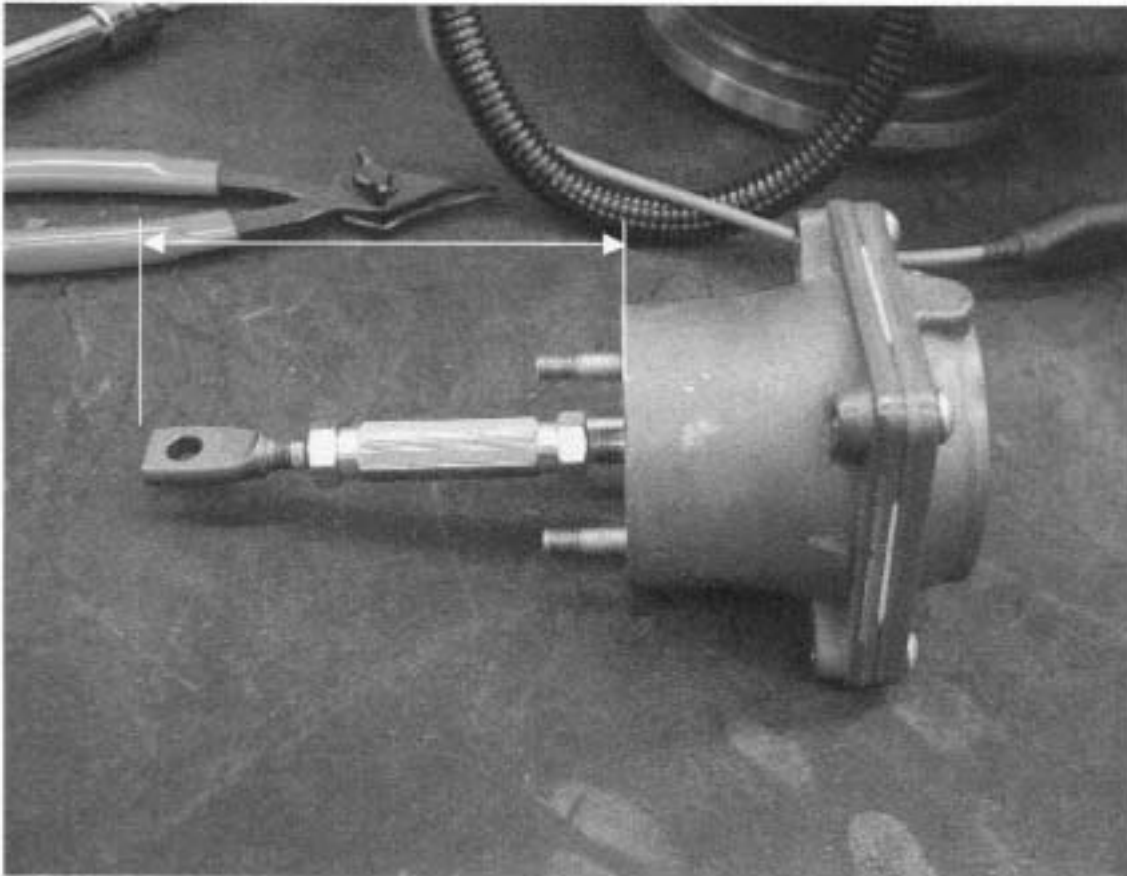

Figure 2

N.G. Veach  
Technical Service



**No.: 04 TS - 17**  
March 26, 2004

**TO:** All Distributors, Branches and Dealers  
**ATTN.:** Service Manager  
**FROM:** M. F. Kubiak  
**SUBJECT:** Flash code 13 & 16 – DDEC V, EGR Valve Current High or Low

Two new codes were added to these flash codes with the release of DDEC V.

Flash code 13 is defined as 146 / 6 EGR valve current too high  
Flash code 16 is defined as 146 / 5 EGR valve current too low

These codes are designed to diagnose faults with the new EGR valve.

These codes have been logged without an actual failure of the valve or wiring.

On March 8 2004, a change was made to all Series 60 DDEC V calibrations to prevent false code 13 or 16 from turning on the check engine light (amber warning lamp). Any programming performed after this date will prevent this code from being logged.

There was not a change to the ECM software, only the calibrations were modified.

If this (these) code(s) are encountered, the first step in troubleshooting should be to first program the ECM.

Thank you for your assistance and support.

Marty Kubiak  
Customer Assurance

